

16691



Call Us First!

DO NOT RETURN TO STORE.

For immediate help with assembly or product information
call our toll-free number:

1-800-577-9663

or email:

customerservice@backyardproductsllc.com

Our staff is ready to provide assistance.

April through October M - F 8:00 AM to 7:00 PM EST

Saturday 8:30 AM to 4:30 PM EST

November through March M - F 8:00 AM to 5:00 PM EST

ANTES DE DEVOLVERLO, ¡LLÁMENOS!

Si desea más información sobre el montaje, llámenos sin coste
adicional alguno al siguiente teléfono:

+1-800-577-9663

o correo electrónico:

customerservice@backyardproductsllc.com

Nuestro personal le proporcionará toda la ayuda que necesite.

Abril por octubre M - F 8:00 ESTA a 7:00 P.M. EST

el sábado 8:30 ESTA a 4:30 P.M. EST

noviembre por marzo M - F 8:00 ESTA a 5:00 P.M. EST



Customer Service

1-800-577-9663
1000 Ternes Drive
Monroe, MI 48162

10' and 12' Oval Gazebo Instructions

- BEFORE YOU BEGIN -

Always wear OSHA-APPROVED safety glasses throughout assembly process

■ First...

Read these instructions thoroughly before you begin assembly. Assembly is easiest if you follow the steps in the order shown. In a drawing, a dotted line represents a part hidden from view (like a part under a panel). Lumber is graded from only one side. Check the part for the most attractive face and make sure to face it to the outside.

■ Check all parts

Compare parts you have to the list on page 2. If a part is missing, circle the part in question in the parts list and call us toll-free at 1-800-827-9056.

■ Assistance required

We recommend that you assemble this Gazebo on level ground in the location it will be used. Assistance is necessary to handle, fit, and secure some components. Two people are needed for some steps.

■ Check local zoning

Before starting construction, check with your local building code official for any required *permits, variances, etc.*

■ Check Floor Kit Size

Before starting construction on your floor, make sure that you check in the instruction manual to make sure that you are building the correct size floor kit for your Gazebo. See page 3 for more information.

- TREATING YOUR GAZEBO -

■ Staining...

This Gazebo is constructed of a long-lasting western cedar. Untreated cedar exposed to sunlight will eventually weather to a silver-grey color. To validate your warranty and to help keep the original red color, read your warranty page on maintaining your Gazebo. Apply a minimum of two coats of oil based penetrating stain WITHIN 30 DAYS (required by warranty). Some sanding to remove rough edges and natural wood stains may be required prior to staining. Your Gazebo roof is not waterproof unless it is shingled. Caulking the roof seams before shingling will improve the water resistance of your Gazebo.

STAIN REQUIREMENTS FOR GAZEBOS

SIZE	# OF GALLONS	Add for Options	
		FLOOR	SCREEN KIT
10'	2	1	.5
12'	3	1	.5

■ Tools required

- Hammer
- #2 Phillips Screwdriver
- 6' Step Ladder
- Tape Measure
- Pencil

■ Optional tools

- Electric Drill w/ #2 Phillips Tip
- Nail Pouch
- 1/8" and 3/16" Drill bit-for predrilled holes
- Wood Glue

#16691

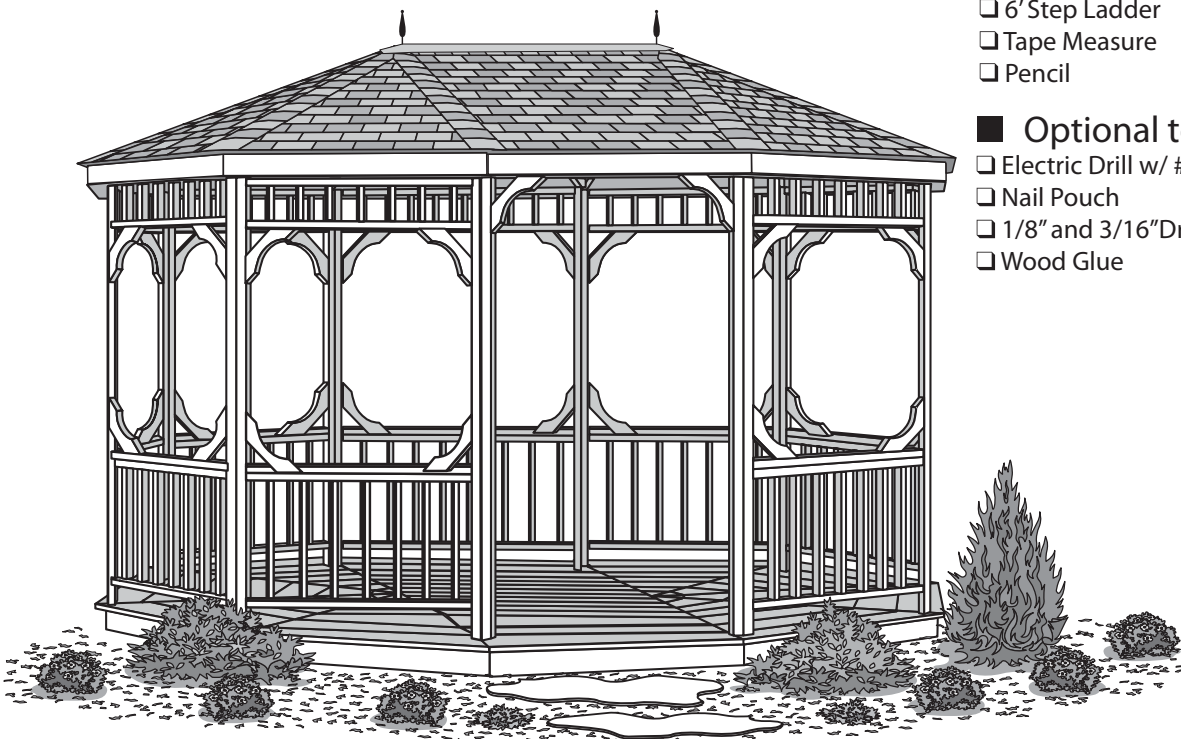

Monterey 10'x14' - 10 sided Gazebo shown with optional Floor Kit (Not Included)
Monterey 12'x16' - 12 sided Gazebo (not shown)

10' and 12' Oval Gazebo

10-Sided

12-Sided

■ Parts List Monterey 10'

- 8 pcs. Pre-assembled Wall Panels 44-3/4" x 82-1/2"
- 1 pc. Square End Pre-assembled Wall Panel 44-3/4" x 82-1/2"
- 1 pc. Square End Pre-assembled Door Panel 44-3/4" x 82-1/2" with Spacer
- 18 pcs. Corbels 2 x 4 x 14"
- 6 pcs. Plywood Gusset Brackets
- 4 pcs. 2 left/2 right Plywood Gusset Brackets
- 10 pcs. Rafters 2 x 4 x 62-3/4"
- 4 pcs. Center Rafters 2 x 4 x 65-9/16"
- 2 pcs. Ridge Block 8-Sided
- 1 pc. Underside Ridge Cover
- 2 pcs. Center Rafter Support 2 x 4 x 43-1/4" angled ends
- 3 pcs. Rafter Support Spacers 1/2" x 3-1/2" x 6"
- 1 pc. Metal Oval Cover
- 8 pcs. Plywood Triangular Roof Panels
- 2 pcs. Plywood Square Roof Panels 5/8" x 44-3/4" x 65-3/4"
- 9 pcs. Sill Plates Notched 2 x 4 x 40-1/4"
- 8 pcs. Fascia 5/8" x 3-1/2" x 46-7/8" Plywood
- 2 pcs. Fascia 5/8" x 3-1/2" x 44-3/4" Plywood
- 10 pcs. Fascia Trim
- 2 pcs. Roof Finial Block 1-1/2" x 1-1/2" x 3-1/2"
- 2 pcs. Roof Finial

■ Hardware Kit

- #8 - 3" Screw, #8 - 1-5/8" Screw, #8 - 2-1/2" Screw, 6d-2" Nail, 4d-1-1/2" Finish Nail, 3/4" Roofing Nail, 1" Roofing Nail

■ Parts List Monterey 12'

- 10 pcs. Pre-assembled Wall Panels 44-3/4" x 82-1/2"
- 1 pc. Square End Pre-assembled Wall Panel 44-3/4" x 82-1/2"
- 1 pc. Square End Pre-assembled Door Panel 44-3/4" x 82-1/2" with Spacer
- 22 pcs. Corbels 2 x 4 x 14"
- 8 pcs. Plywood Gusset Brackets
- 4 pcs. 2 left/2 right Plywood Gusset Brackets
- 12 pcs. Rafters 2 x 6 x 78-3/8"
- 4 pcs. Center Rafters 2 x 6 x 81-1/4"
- 2 pcs. Ridge Block 10-Sided
- 1 pc. Underside Ridge Cover
- 2 pcs. Top Cover
- 2 pcs. Center Rafter Support 2 x 6 x 43-1/16" angled ends
- 3 pcs. Rafter Support Spacers 2 x 6 x 2-3/16"
- 1 pc. Metal Oval Cover
- 10 pcs. Plywood Triangular Roof Panels
- 2 pcs. Plywood Square Roof Panels 5/8" x 44-3/4" x 80-3/8"
- 11 pcs. Sill Plates Notched 2 x 4 x 40-1/4"
- 10 pcs. Fascia 5/8" x 3-1/2" x 46-3/8" Plywood
- 2 pcs. Fascia 5/8" x 3-1/2" x 44-3/4" Plywood
- 12 pcs. Fascia Trim
- 2 pcs. Roof Finial Block 1-1/2" x 2-1/2" x 3-1/2"
- 2 pcs. Roof Finial

■ Hardware Kit

- #8 - 3" Screw, #8 - 1-5/8" Screw, #8 - 2-1/2" Screw, 6d-2" Nail, 4d-1-1/2" Finish Nail, 3/4" Roofing Nail, 1" Roofing Nail

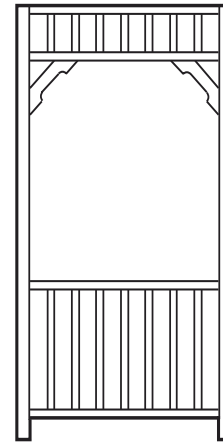

PRE-ASSEMBLED WALL PANEL

(1 with no angle cut)

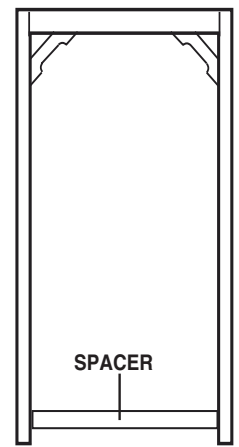

PRE-ASSEMBLED DOOR PANEL



ROOF FINIAL

SILL PLATE

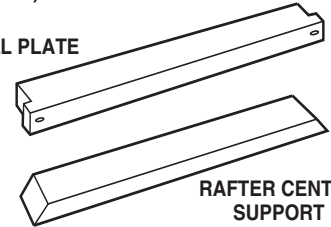

RAFTER CENTER SUPPORT

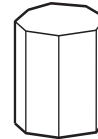

10' RIDGE BLOCK



CORBELS

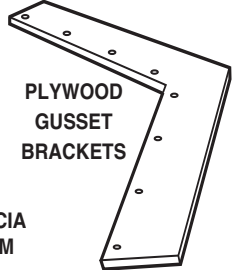

PLYWOOD GUSSET BRACKETS

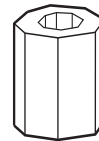

12' RIDGE BLOCK



FASCIA TRIM



UNDERSIDE RIDGE COVER

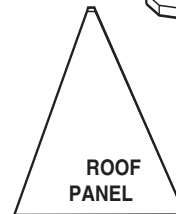

ROOF PANEL



PLYWOOD FASCIA



METAL ROOF CAP

NATIONAL STANDARD LUMBER SIZES

Nominal size	Actual size
1 x 4	= 3/4" x 3-1/2"
2 x 4	= 1-1/2" x 3-1/2"
2 x 2	= 1-1/2" x 1-1/2"
2 x 6	= 1-1/2" x 5-1/2"

FLOOR SYSTEM (Floor system not supplied with kit)

YOU MUST BUILD YOUR GAZEBO ON A FLOOR SYSTEM.

SITE PREPARATION

- Site must be properly leveled.
- Site should have natural drainage to eliminate puddling under and around the building.
- Site should be covered with plastic film to discourage grass growth under the building and to serve as a vapor barrier.

Before assembling your gazebo, you must first construct a floor system.

You can:

A. Purchase our optional pre-cut Floor Kit. Follow instructions included with optional floor kit.

B. Purchase materials to cut and build your own wooden floor.

NOTE: Our Precut Floor Kits have been designed for normal residential use. It is characteristic for the floor panels to deflect (flex) during normal use. If you intend to store very heavy objects in your Gazebo, you may want to consider adding floor joists to reduce the span.

OR

C. Install a 4" concrete slab floor system.

IF USING CONCRETE SLAB FLOOR SYSTEM

- Construct 4" Concrete Slab Floor System.

- Upon completion of above steps, proceed to Step #2: Assembling Wall Panels.

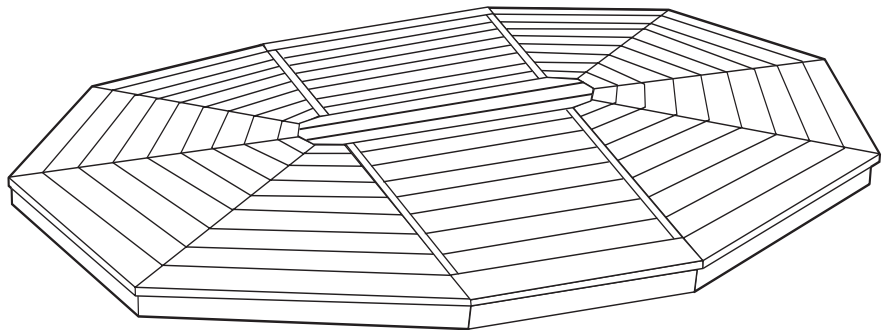

Wooden Floor Kit

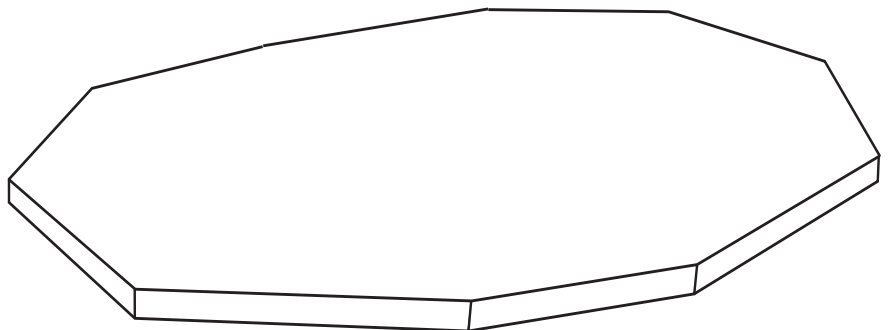

Concrete Slab Floor System

WOOD FLOOR SITE PREPARATION

It is important to have a solid, flat and level foundation for your Gazebo. Carefully consider the recommendations listed below prior to creating your foundation.

Wood Floor Dimensions

LEVEL GROUND INSTALLATION

Remove dirt to allow for Floor Base Plate. Shim outside of frame corners as needed. Follow local codes for anchoring requirement or see local home center for recommendation.

UNEVEN GROUND INSTALLATION

Use treated 4 x 4 posts or concrete piers on each corner and in center of deck. Hole depth will vary according to local building codes. Cut center post 1-1/2" shorter to allow for Base Plate as shown in Fig.1. Nail or screw Deck to top of 4 x 4 posts. Use Simpson Tie or similar for each Concrete pier. See local home center.

HARD SURFACE INSTALLATION

Do Not Use the Base Plate in our Floor Kit for Hard Surfaces. Measurements given on the illustration are 1-1/2" larger than the outside dimensions of the Gazebo. You may choose to make your own floor larger than the dimensions given. **Step 6 page 12 shows you how to anchor your gazebo.** (Anchor Hardware not included in Kit.)

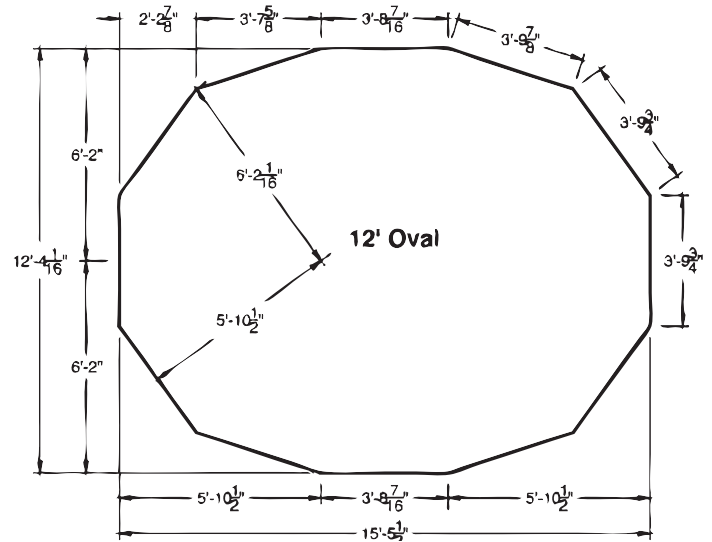
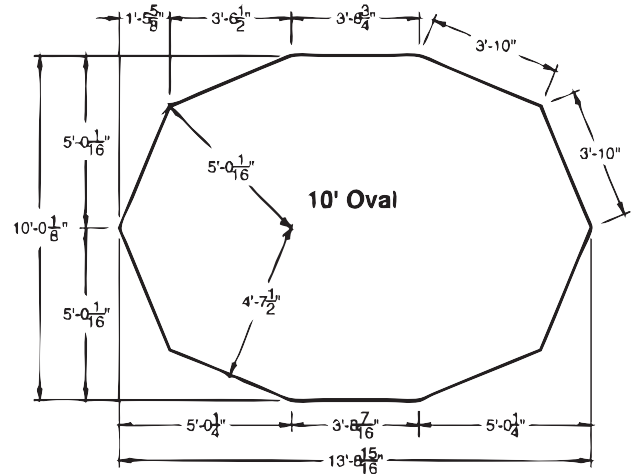
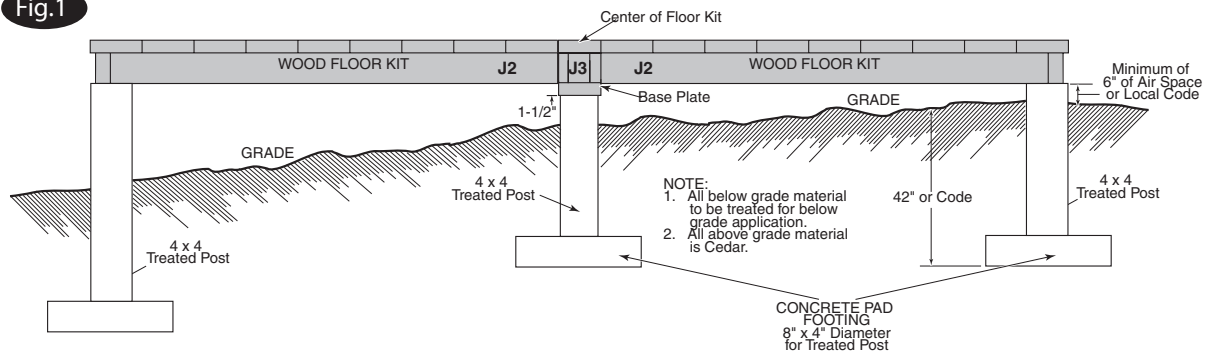

Fig.1



CONCRETE SLAB SITE PREPARATION

It is important to have a solid, flat and level foundation for your Gazebo. Carefully consider the recommendations listed below prior to creating your foundation.

CONCRETE SLAB OR HARD SURFACE INSTALLATION

Measurements given on the **Fig. 1** Concrete Slab Dimensions illustration are 1-1/2" larger than the outside dimensions of the Gazebo. You may choose to make your concrete slab larger than the dimensions given. **Step 6** shows you how to anchor your gazebo. (Hardware not included in Kit.)

Dig out 4" of ground for concrete and 4" for sand/gravel (per local code) so it is level. Finish digging 12" wide by 12" deep (per local code) continuous footing around the perimeter of gazebo foundation area. Use wood forms around the perimeter of gazebo foundation area. Use rebar as needed. Pour concrete and make sure all points of the concrete top are level and see **Fig 2**.

Fig.1 Concrete Slab Dimensions

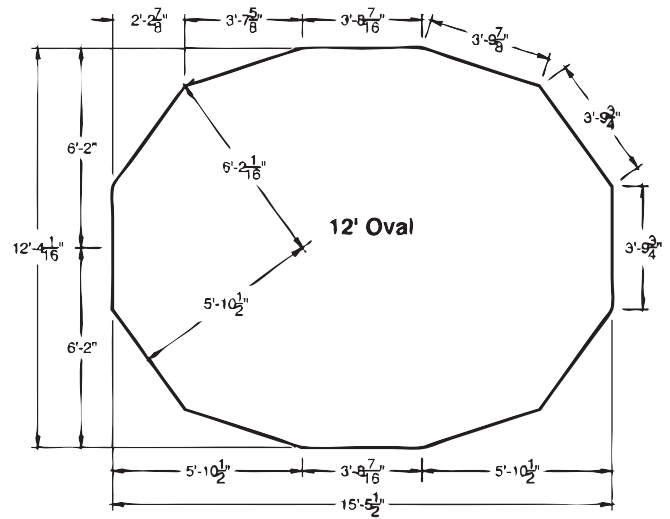
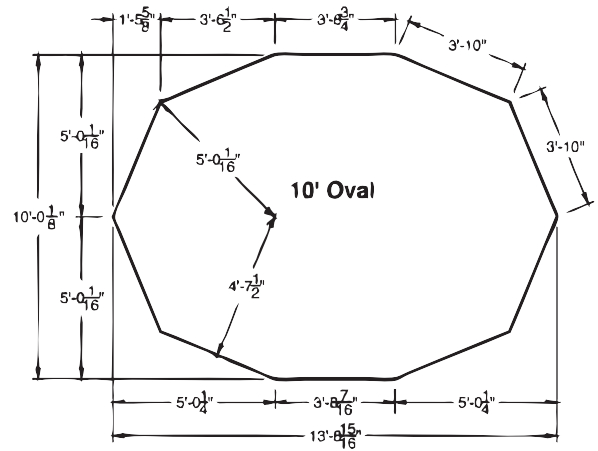
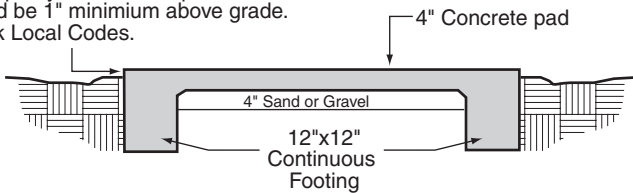

Fig.2

The top of your concrete pad should be 1" minimum above grade. Check Local Codes.



2 ASSEMBLING WALL PANELS

PARTS LIST 10' GAZEBO

- 8 pcs. Pre-assembled Wall Panels
- 1 pcs. Pre-assembled Square end Wall Panel
- 1 pc. Pre-assembled Square end Door Panel

PARTS LIST 12' GAZEBO

- 10 pcs. Pre-assembled Wall Panels
- 1 pcs. Pre-assembled Square end Wall Panel
- 1 pc. Pre-assembled Square end Door Panel

2-A

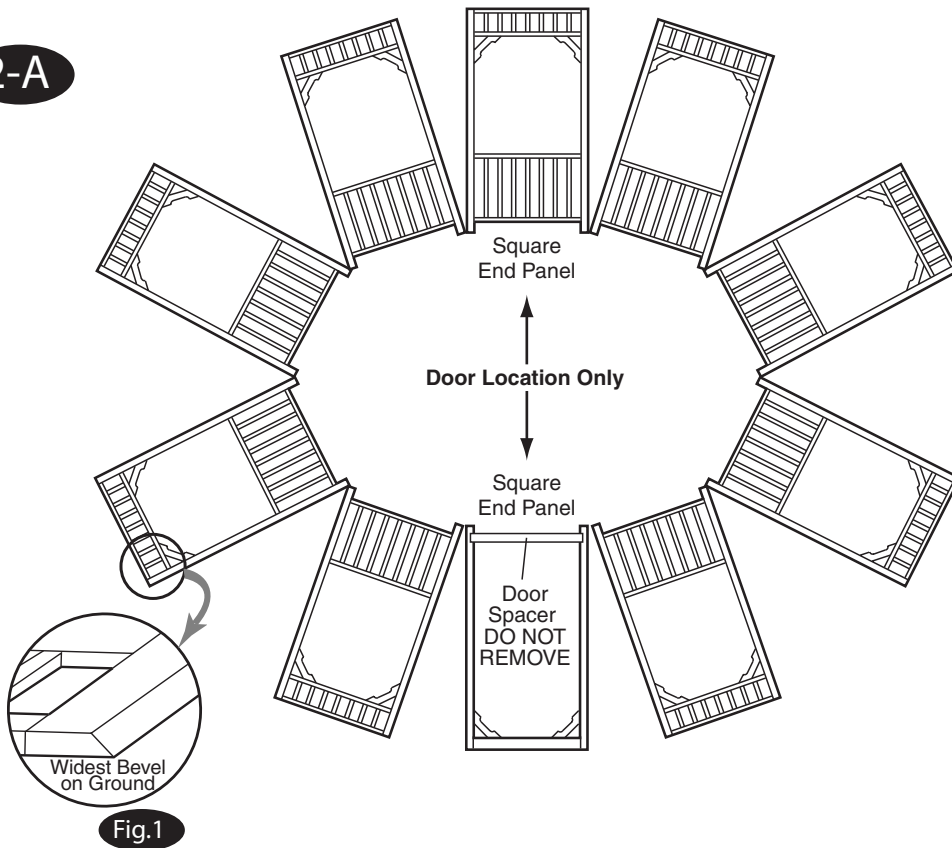

2-A: Select either desired Door location and position Wall Panels on ground around foundation as shown in Fig. 2-A.

If you are constructing the 12' Gazebo, please allow for two additional wall sections when laying out your walls.

NOTE: Wall Panels with beveled edges. The widest bevel will face the ground and is the outside of the Gazebo wall as shown in Fig. 1.

2-B: Stand up two adjoining Wall Panels and attach them together using five 3" screws as shown in illustration 2-B. **HINT: Start at the Top and work Down to the Bottom of Panel.** Make sure that the two Wall Panels are flush at the top as shown in Fig. 2. Connect all Wall Panels in this same manner, making sure not to remove the Door spacer at this time.

Note: Use wood glue (not included) between Wall Panels for added strength.

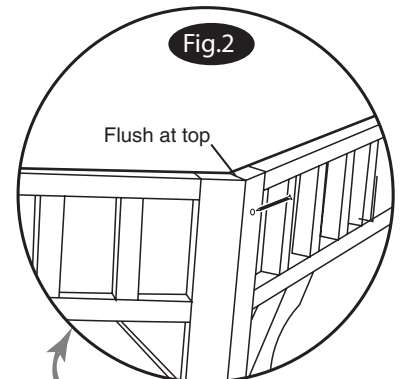

2-B

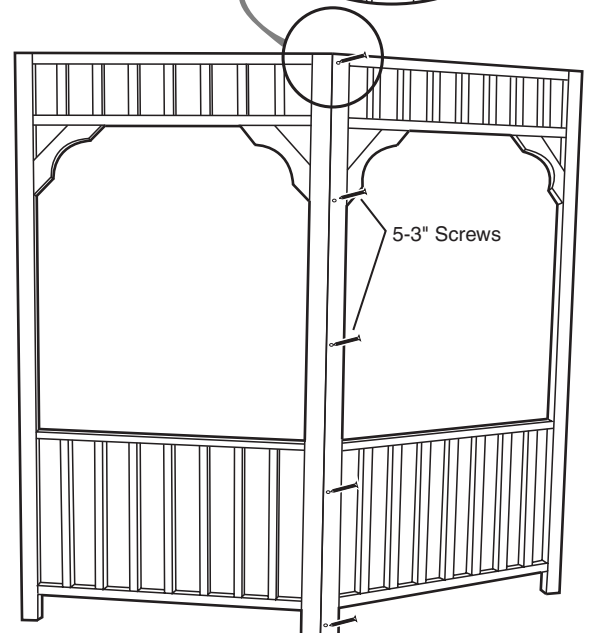

3 INSTALLING GUSSET BRACKETS

PARTS LIST 10' GAZEBO

- 6 pcs. Plywood Gusset Brackets
- 4 pcs. 2 left and 2 Right Gussets

PARTS LIST 12' GAZEBO

- 8 pcs. Plywood Gusset Bracket
- 4 pcs. 2 left and 2 Right Gussets

Note: Use wood glue between Wall Panels and Gussets for added strength and to meet some local building codes. Temporarily install all gussets with 1-5/8" screws to align walls. Remove one gusset at a time, apply glue, and reinstall all screws. Continue for all Gussets.

VIEW FROM INSIDE

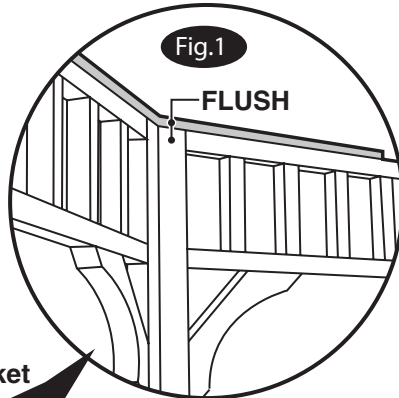

3-A: Install Gusset Brackets with Rough sawn Cedar side facing down using eight 1-5/8" screws for each Gusset. Make sure that the Gusset Bracket is flush to the inside of the Wall Panel and that the inside corner is directly over inside corner of Wall Panel as shown in Fig. 1. The Gusset Bracket should overhang the outside edge of the Wall Panel by 2-1/2" as shown in Fig. 2. This step may require some pulling of the Wall Panel to bring it into proper position. Tip to tip measurement on Gussets is 46-7/8" for 10' Gazebo and 46-3/8" on 12' Gazebo. The gap between Gussets may vary. Note: For all sizes of Monterey, find the 2 right and 2 left Plywood Gusset Brackets that have the extra holes drilled, see Fig. 3. These will go above door and opposite wall.

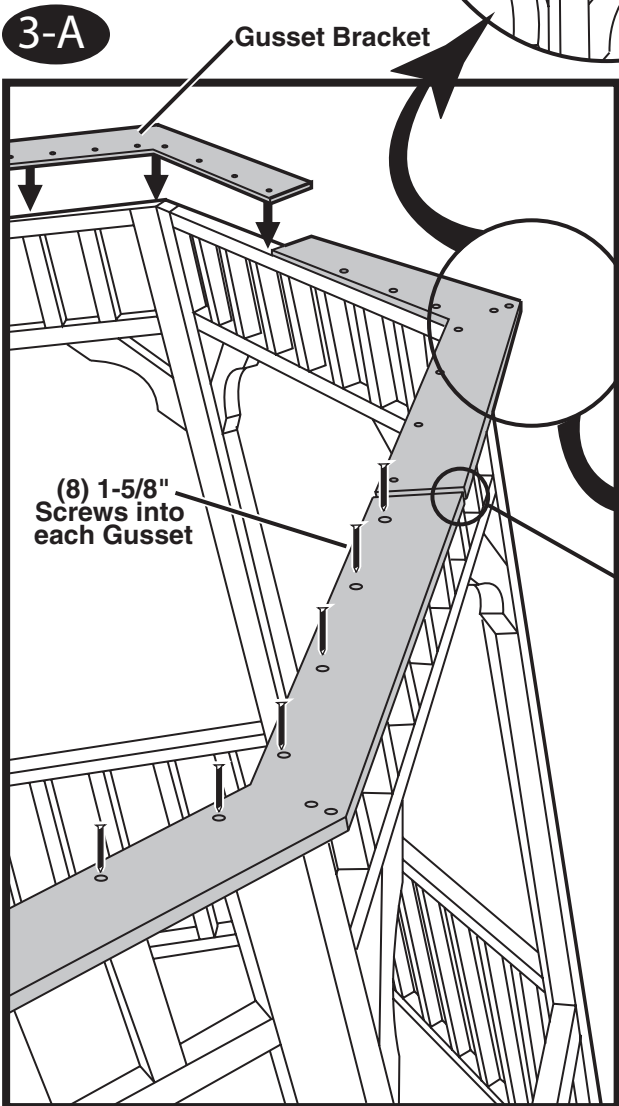

VIEW FROM OUTSIDE

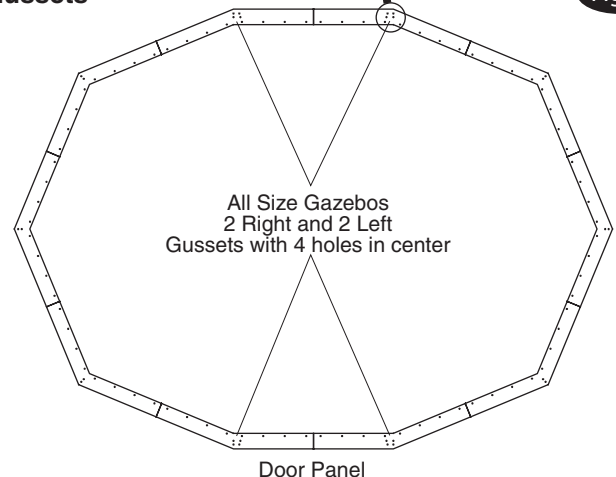
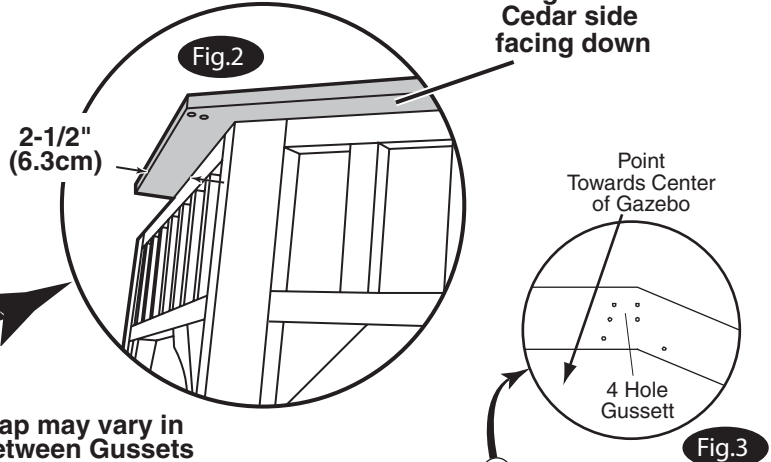

4 RIDGE ASSEMBLY

PARTS LIST 10' GAZEBO		
□ 2 pcs.	Center Rafter Support	2 x 4 x 43- ¹ / ₄ "
□ 3 pcs.	Center Spacer	¹ / ₂ " x 3- ¹ / ₂ " x 6"
□ 2 pcs.	Solid Ridge Block 8 sided	
PARTS LIST 12' GAZEBO		
□ 2 pcs.	Center Rafter Support	2 x 6 x 43- ¹ / ₁₆ "
□ 3 pcs.	Center Spacer	2 x 6 x 2- ³ / ₁₆ "
□ 2 pcs.	Hollow Ridge Block 10 sided	

10' Assembly

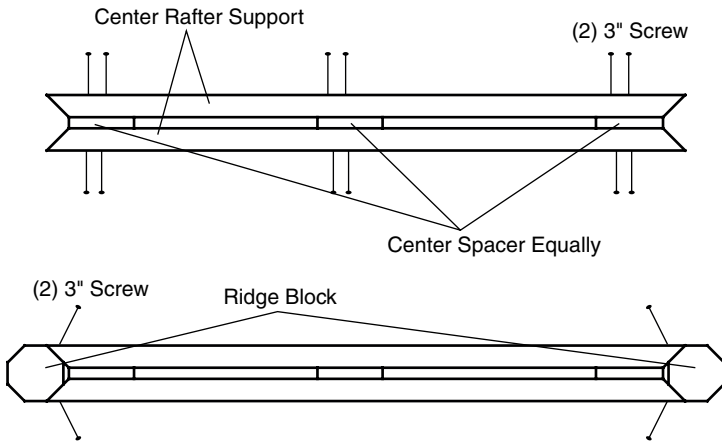

4-A: 10' Gazebo - Layout Center Rafter Support (angled) and Center Support Spacers equally as shown. Use (2) 3" screws staggered as shown into each spacer. Install 2 solid ridge blocks as shown with 3" screws. Note: Keep Pre-drilled holes in Ridge Block to Bottom.

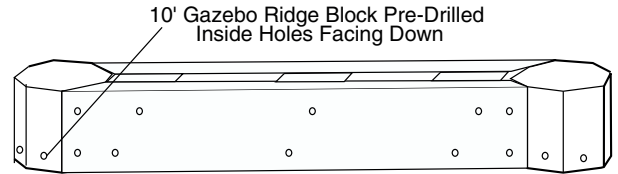

12' Assembly

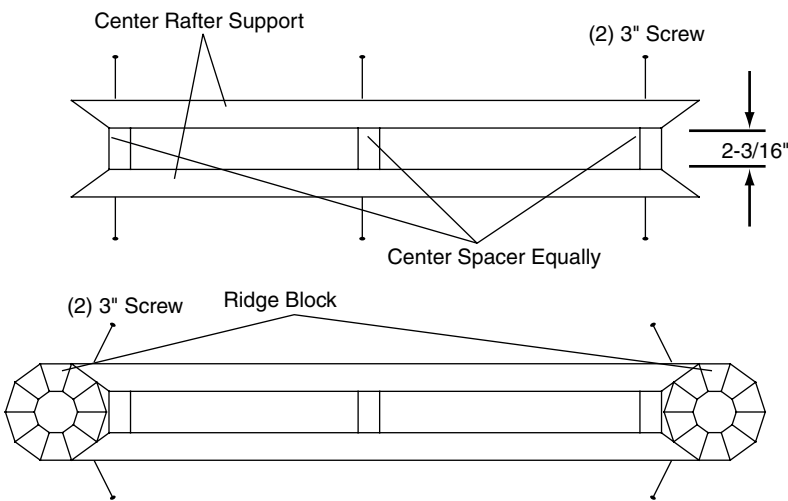

4-A: 12' Gazebo - Layout Center Rafter Support (angled) and Center Support Spacers equally as shown. Use (2) 3" screws into each spacer as shown. Install Hollow Ridge Blocks as shown with 3" Screws and keep flush to bottom.

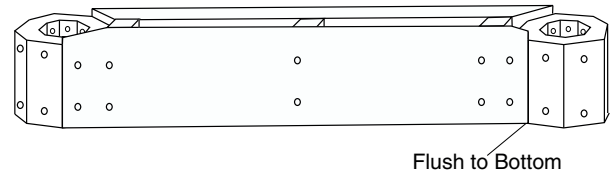

5

ERECTING RAFTERS

PARTS LIST 10' GAZEBO

- 10 pcs. Rafters 2x4x62-3/4"
- 4 pcs. Center Rafters 2x4x65-9/16"
- 1 pc. Ridge Assembly from 4A

PARTS LIST 12' GAZEBO

- 12 pcs. Rafters 2x6x78-3/8"
- 4 pcs. Center Rafters 2x6x81-1/4"
- 1 pc. Ridge Assembly from 4A

5-A: Attach rafters 1, 2, 3, 4 to Ridge assembly first. Follow securing method as in **Step 5-B or 5-C**. Set assembly on Gussets and attach with 3" screws as in **Step 5-D, Fig. 2**. Keep the center on these rafters 44-3/4" apart at the top and bottom. In windy conditions, have a second person hold this assembly in place until rafters 5 and 6 are installed. Layout and attach remaining rafters according to 5-A for easier assembly. Install the required rafters in the same manner for 12' model gazebos.

NOTE: Adjust Wall corners in or out to fit.

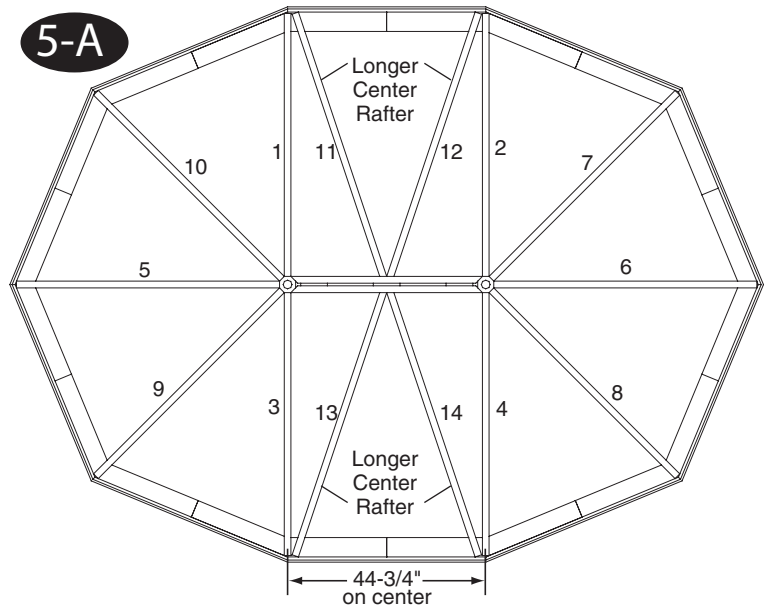

If you are assembling a 12' Gazebo, please begin with step 5-C, if you are assembling a 10' Gazebo, please go to step 5-B. Note: step 5-B and 5-C only shows the method for securing rafter to ridge assembly, follow step 5-A for proper assembly.

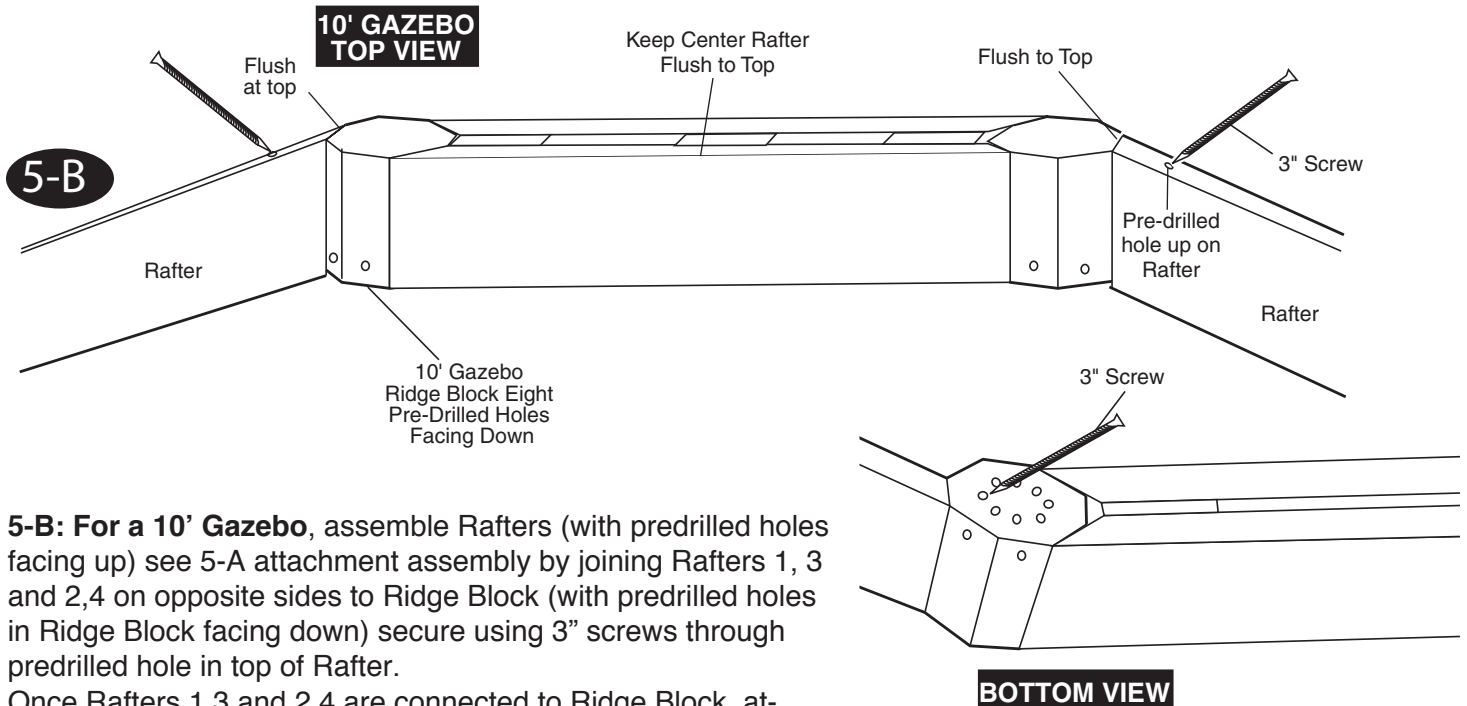

5-B: For a 10' Gazebo, assemble Rafters (with predrilled holes facing up) see 5-A attachment assembly by joining Rafters 1, 3 and 2,4 on opposite sides to Ridge Block (with predrilled holes in Ridge Block facing down) secure using 3" screws through predrilled hole in top of Rafter.

Once Rafters 1,3 and 2,4 are connected to Ridge Block, attach two 3" screws through the bottom predrilled holes in Ridge Block into Rafter. With help, place this assembly on top of Gazebo Gussets where indicated. Please follow step 5-D at this time.

5

ERECTING RAFTERS CONTINUED

5-C: For 12' Gazebo, assemble Rafters by joining Rafters 1,3 and 2,4 on opposite sides to Ridge Block using 3" screws through predrilled holes in center of Hollow Ridge Block. Leave a 1/2" overhang between the top and bottom of the rafter and the Ridge block.

Once Rafters 1,3 and 2,4 are connected to Ridge Block, carefully turn over and attach 3" screws through predrilled holes in Ridge Block into Rafter. With help, place this assembly on top of Gazebo Gussets where indicated. Please follow step 5-D at this time.

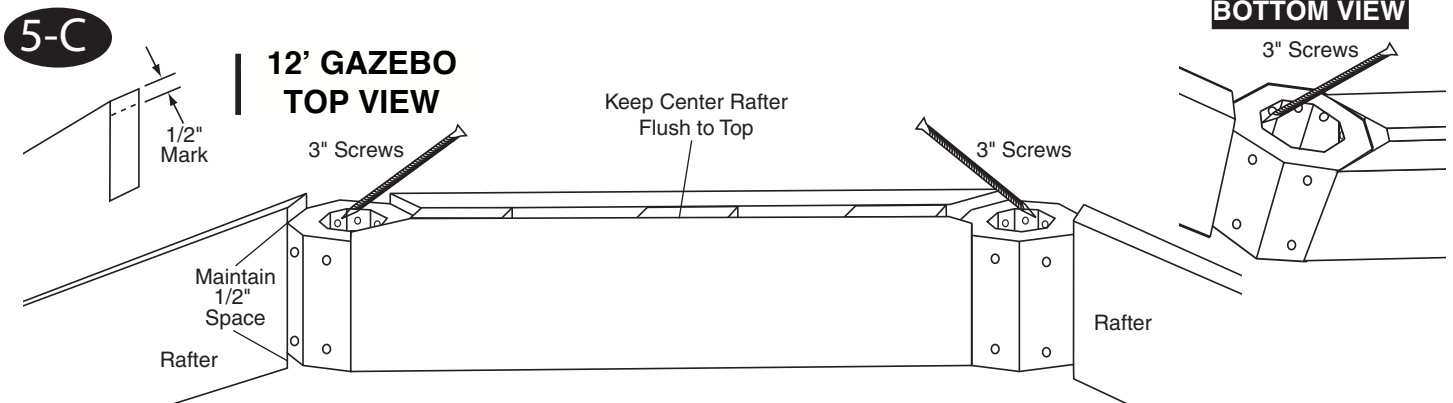

5-D: Attach Rafters 1, 2, 3,4 by inserting 3" Screws through Gusset Bracket, as shown in 5-D Fig. 2, while holding Rafter in position. Attach remaining rafters (See 5-A) with 3" screws through Gusset Bracket first then install 3" Screws through top of Rafter into Ridge Assembly as shown in Fig. 1 and as in 5-B or 5-C. Once all Rafters are in place, make sure (2) 3" screws are connecting Rafters from each end.

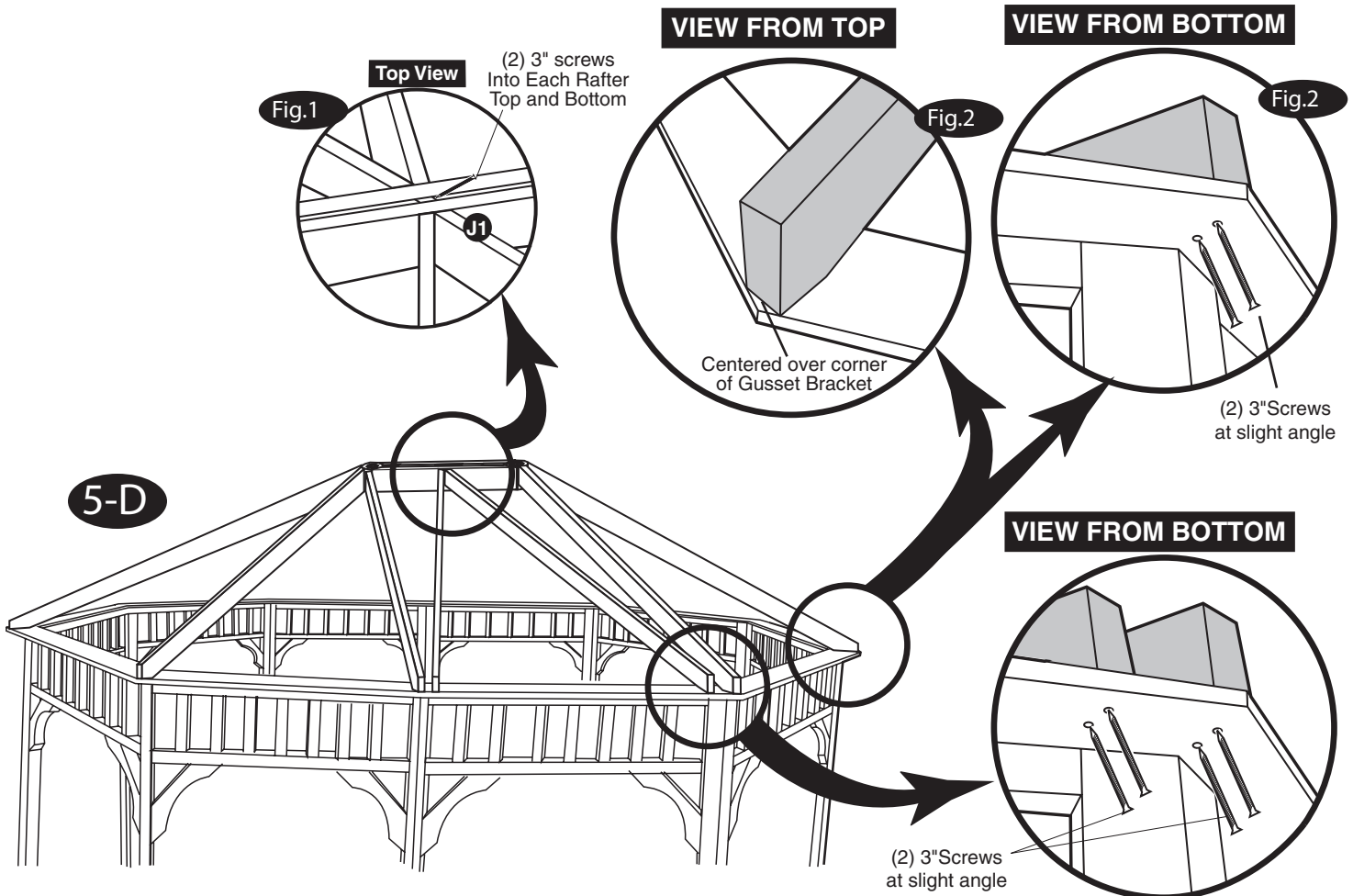

5 ERECTING RAFTERS CONTINUED

PARTS LIST 10' GAZEBO

- 1 pc. Underside Ridge Cover
- 2 pcs. Roof Finial Block 1-1/2x1-1/2x3-1/2"

PARTS LIST 12' GAZEBO

- 1 pc. Underside Ridge Cover
- 2 pcs. Roof Finial Block 1-1/2x2-1/2x3-1/2"
- 2 pcs. Top Cover

5-E: Attach Underside Ridge Cover to ridge with (6) 1-5/8" screws as shown in **Fig. 1**.
For 12' Gazebo, attach Top Covers to top of Hollow Ridge Block with (4) 1-5/8" screws as in **Fig.2**.

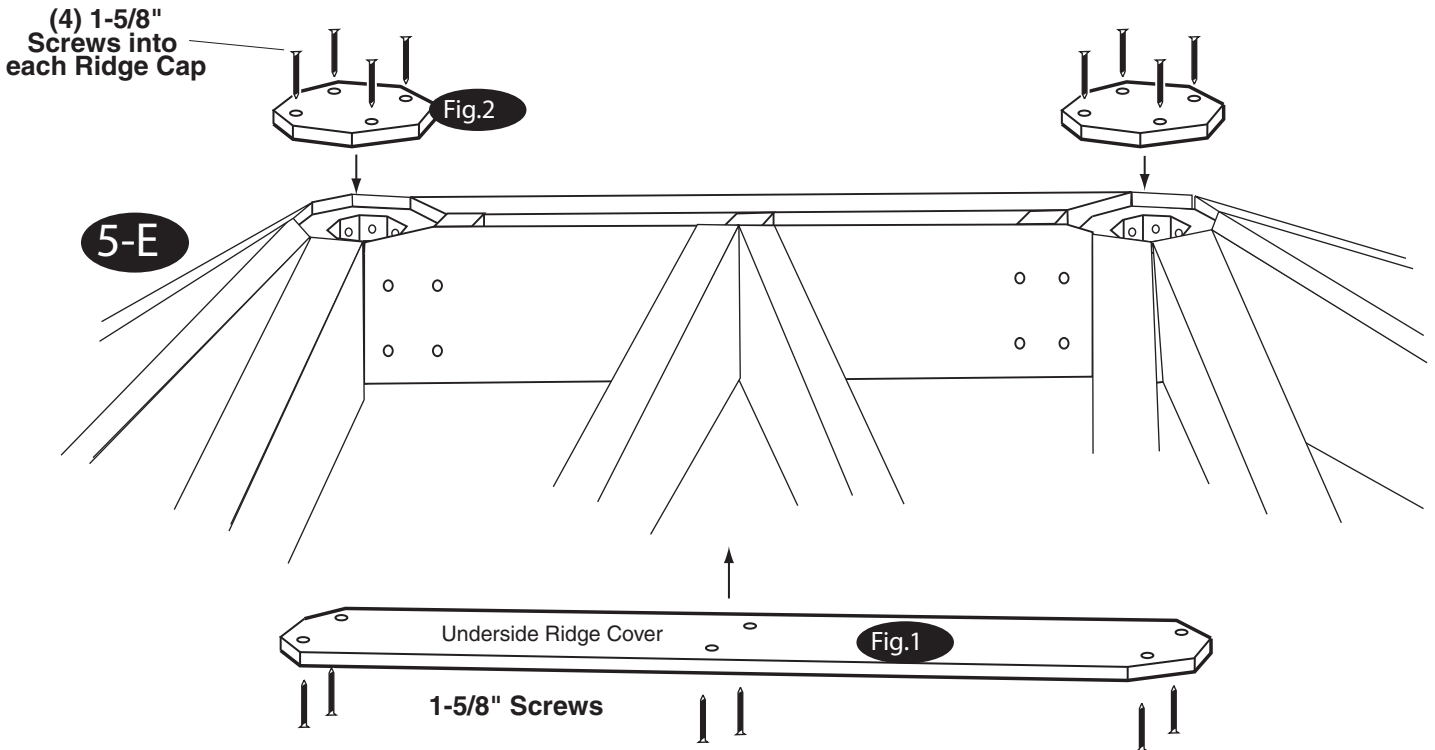

5-F: Add Roof Finial Block to top as shown with 3" screws . Use predrilled holes to keep from splitting.

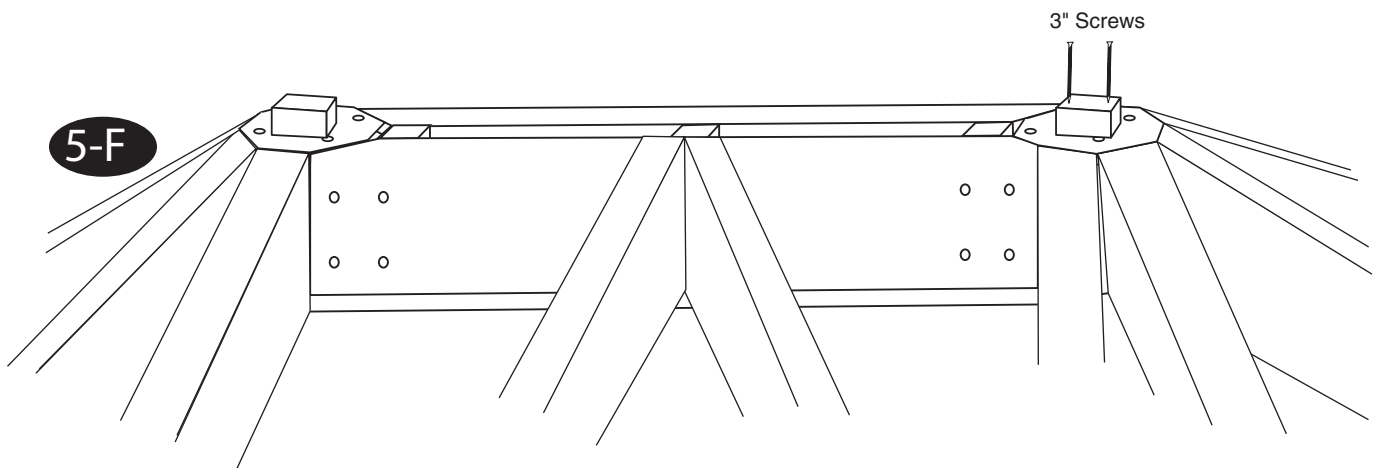

6

ANCHORING GAZEBO

PARTS LIST

- Assembled Side Wall and Rafters
- Anchor or Brackets and Screws
(Not included in Kit)

Check with our local Building Code Department for any variances.

6-A: Anchor to wood floor by predrilling holes and installing two 3" screws at an angle through corner post into wood floor as shown in **Fig. 1**. There should be equal distance between outside of Gazebo and outside edge of floor all around Gazebo as shown in **Fig. 1**.

ANCHORING ON WOOD FLOOR OR WOOD DECK

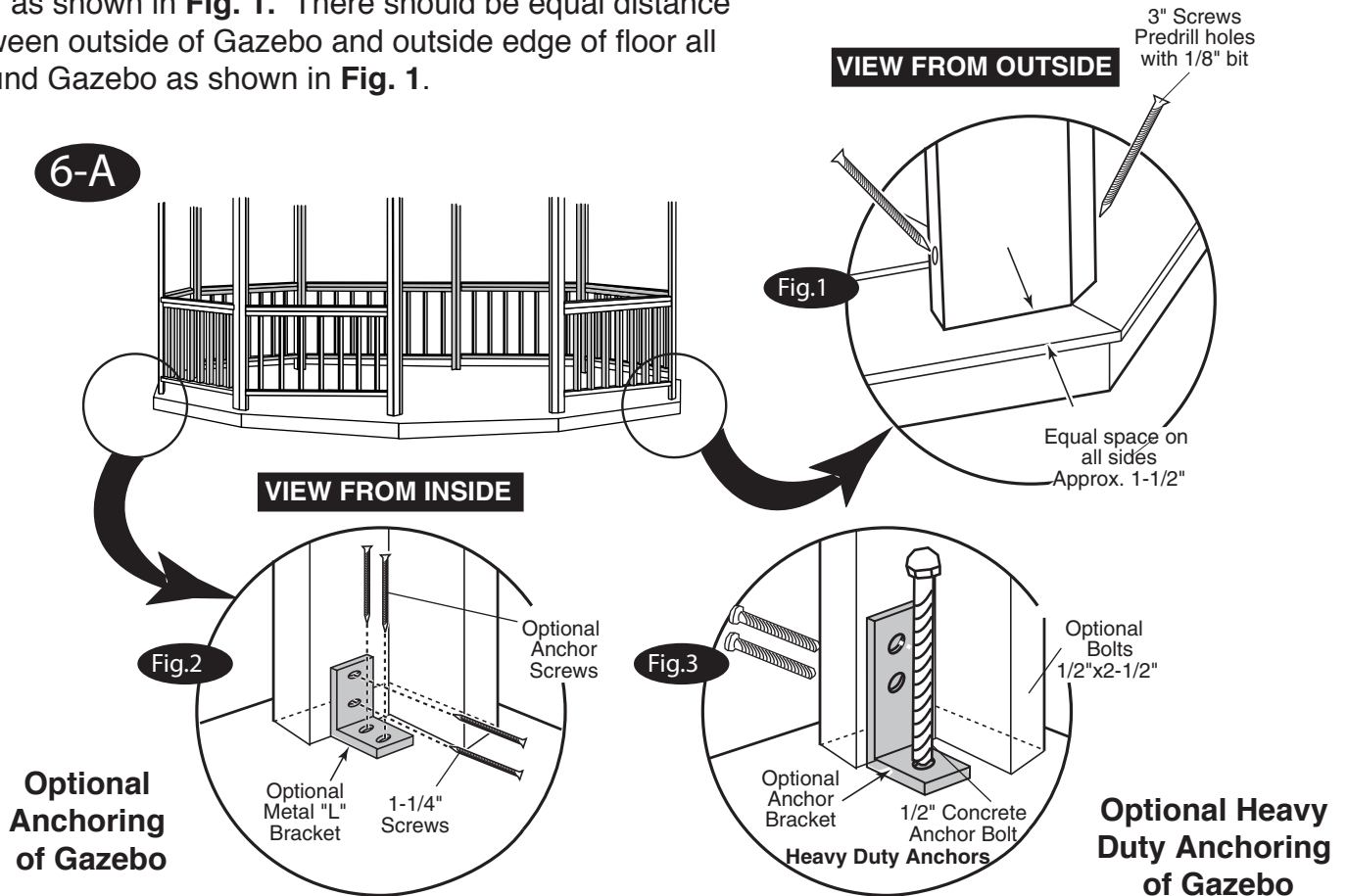

OPTIONAL ANCHORING

Install a 2" 90 degree metal angle bracket (available at most Home Centers and hardware stores) inside each corner post, using a cement anchor, and affixing it to the base with 1-1/4" screws into the post as shown in **Fig. 2**.

Local building departments require some sort of anchoring system to meet wind requirements. We recommend Simpson HD2A (available at most Home Centers and hardware stores) or similar for an anchor as shown in **Fig. 3**. You will also need (2) 1/2"x3" bolts (not included) with a rating of 500 lbs. of tension or greater each bolt, (2) washers and nuts also for the wall to anchor connection. Also you will need a Simpson 1/2" or 5/8" Wedge-All anchor, Titen Hd or similar (available at most Home Centers and hardware stores) for the anchor to concrete connection. If you have a wood floor you would need a 12" long Wedge-All and a 6" long for a Concrete slab. Anchors need to be imbedded at least 4-1/2" into concrete.

7

INSTALLING ROOF PANELS FOR 10' & 12' GAZEBO

* For 14' Models, continue with next page.

PARTS LIST 10' GAZEBO

- 8 pcs. Plywood Triangular Roof Panels
- 2 pcs. Plywood Square Roof Panels

PARTS LIST 12' GAZEBO

- 10 pcs. Plywood Triangular Roof Panels
- 2 pcs. Plywood Square Roof Panels

NOTE: Make certain the rough cedar sawn side of each Roof Panel is facing down during assembly.

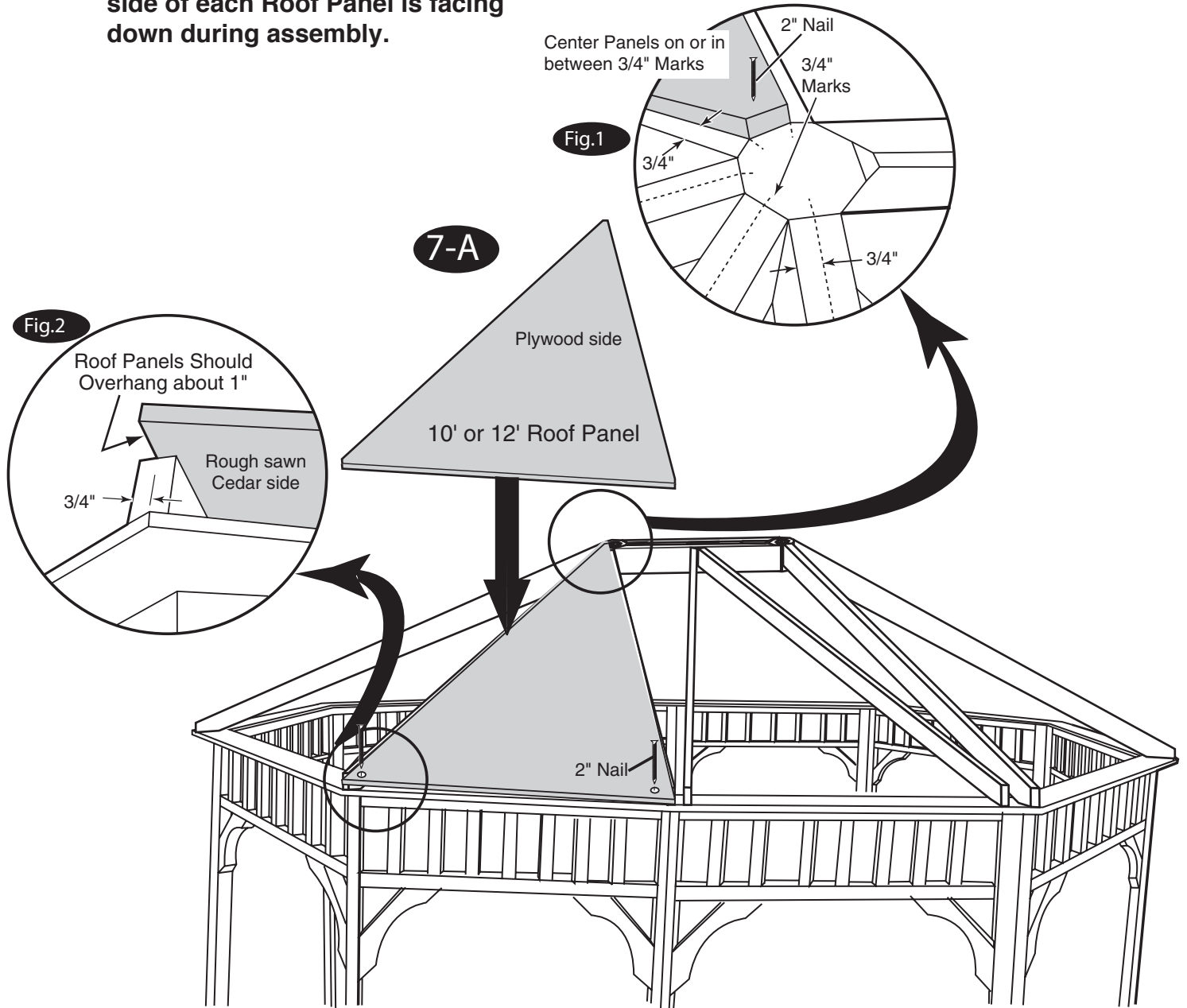

7-A: When installing the Roof Panels, the rough sawn cedar side should be facing to the inside of your Gazebo. Along each Rafter, place a mark 3/4" in on each Rafter to help center Roof Panels as shown in **Fig. 1** and **Fig. 2**. Set first Roof Panel in place on top of Rafters, making top of Roof Panels line up where Rafter and Ridge Block meet and nail with one 2" nail at the top of Roof Panel. Once top is nailed, make sure Roof Panel at bottom is centered between 3/4" marks on both Rafters. Panel should overhang about 1". Once Roof panel is aligned nail with two 2" nails at bottom corners. Go to step 7-B.

7

INSTALLING ROOF PANELS CONTINUED

7-B

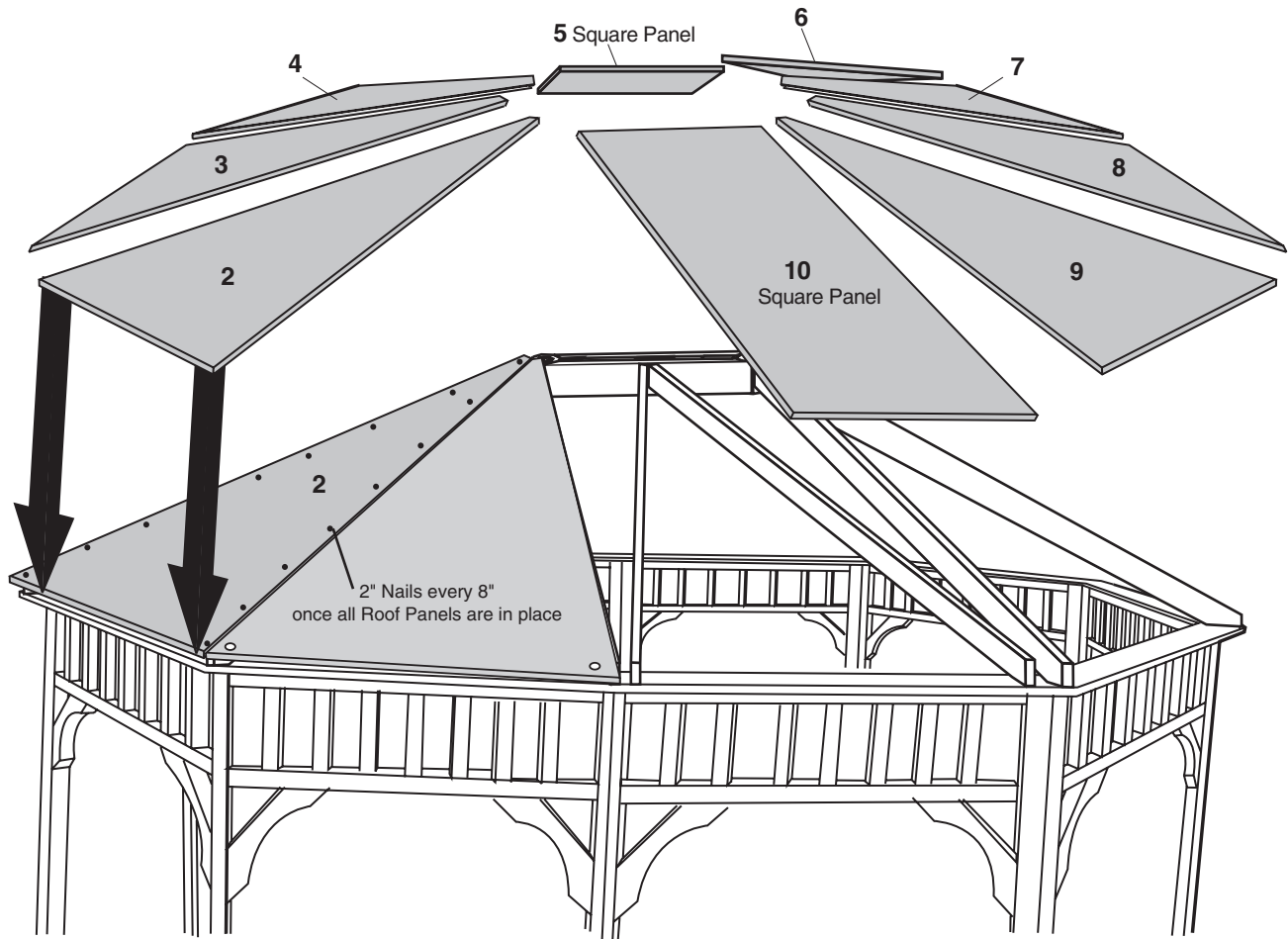

7-B: Follow the same steps as in **7-A** to install all remaining Roof Panels, **only temporarily nailing in place**. Once all Roof Panels are in place and fit properly on your Gazebo, then nail every 8" with 2" nails. 10' model has ten Roof Panels, 12' model has twelve Roof Panels.

8 INSTALLING FASCIA

PARTS LIST 10' GAZEBO

- 8 pcs. Fascia 5/8" x 3-1/2" x 46-7/8" Plywood
- 2 pcs. Fascia 5/8" x 3-1/2" x 44-3/4" Plywood
- 10 pcs. Fascia Trim

PARTS LIST 12' GAZEBO

- 10 pcs. Fascia 5/8" x 3-1/2" x 46-3/8" Plywood
- 2 pcs. Fascia 5/8" x 3-1/2" x 44-3/4" Plywood
- 12 pcs. Fascia Trim

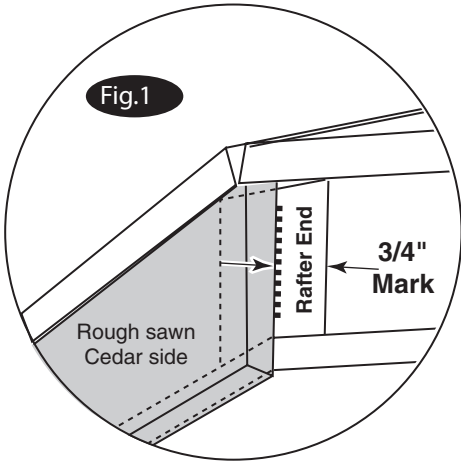

8-A: Place a mark 3/4" in on end of Rafter as shown in **Fig. 1**. Center Fascia on Wall Panels in between corners and 3/4" marks and butt Fascia to bottom of Roof Panels. **Tack on the Fascia to the Gusset Brackets at each corner with one 1-1/2" Finish Nails.** Continue attaching remaining pieces of Fascia. The 2 shorter 44-3/4" Fascia will go over the door and the opposite side. Once all Fascia are in place, finish nailing along bottom edge and top of roof panel with five more 1-1/2" Finish Nails.

Attach Fascia Trim over seam where two Fascia panel pieces meet and attach with two 1-1/2" Finish nails (predrill) through Fascia Trim into Fascia Panel as shown in **Fig. 2**.

Note: Predrill to eliminate splitting the wood when nailing Fascia and Fascia Trim.

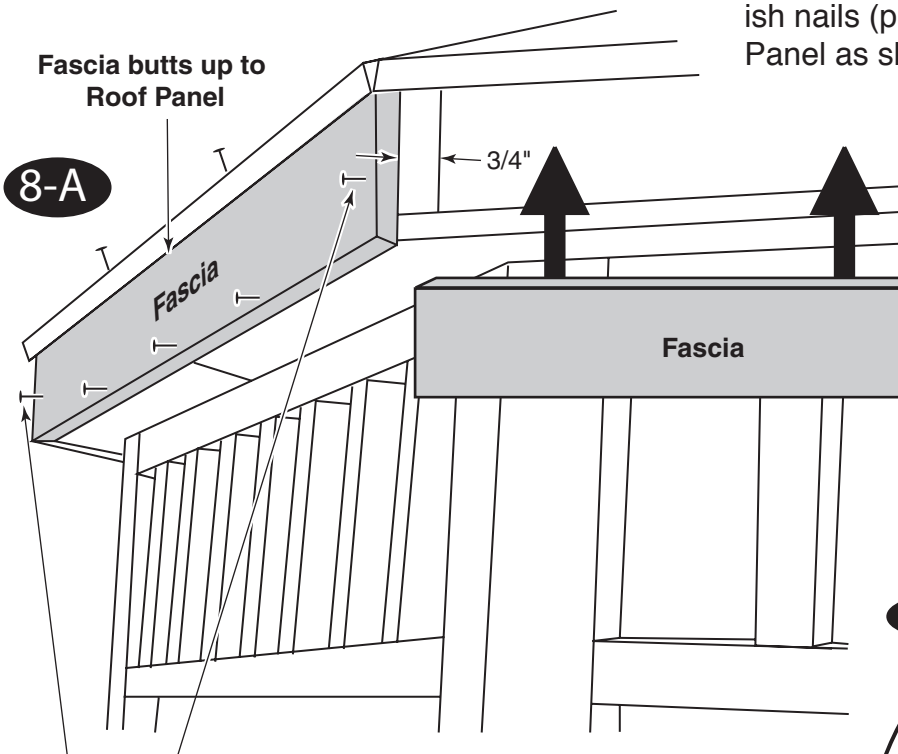

Two-1-1/2" Finish Nails to hold all Fascia in place then, once all Fascia in place, add five more 1-1/2" Finish Nails.

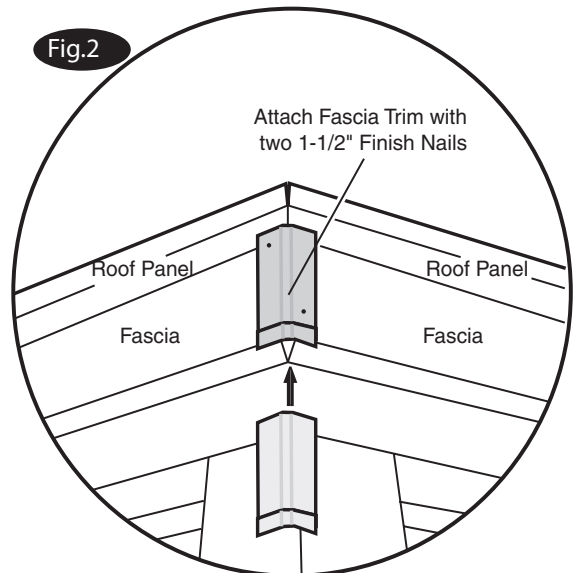

Note: If installing a Screen Kit, skip Step 9 and refer to Screen Kit instruction manual before going to Step 10.

9 INSTALLING SILL PLATE

PARTS LIST 10' GAZEBO

- 9 pcs. Sill Plates 2 x 4 x 40-1/4"
- 18 pcs. Corbels 2 x 4 x 14"

PARTS LIST 12' GAZEBO

- 11 pcs. Sill Plates 2 x 4 x 40-1/4"
- 22 pcs. Corbels 2 x 4 x 14"

9-A: Install Window Sill Plates with ears projecting to the inside of the Gazebo. Attach with (2) 3" screws and (2) 2-1/2" screws as shown in **9-A**.

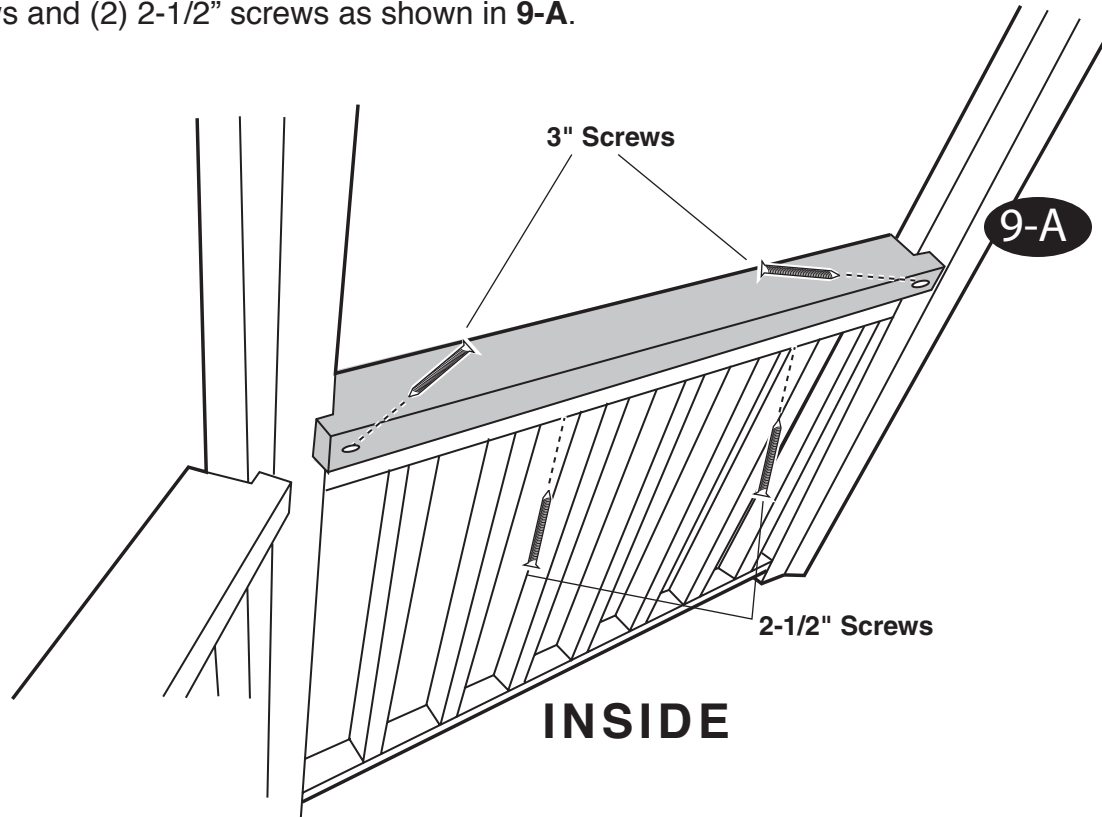

10 INSTALLING LOWER CORBELS

10-A: Lower Corbels are positioned and attached to wall post and sill as shown. Position 3/4" back from Outside Edge of Sill Plate. Secure with 3" screws.

Note: If installing sill from optional Screen Kit, Lower Corbels will be flush to outside edge of Sill Plate.

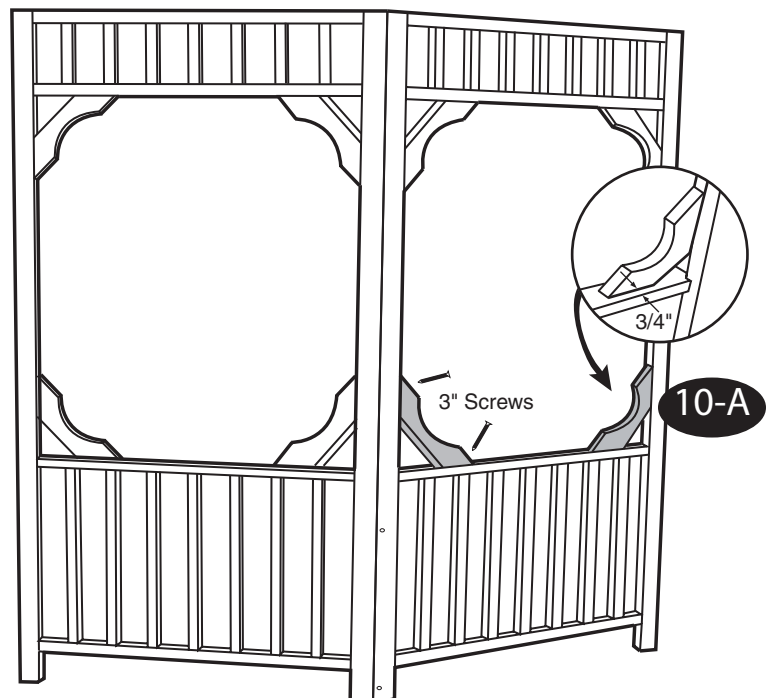

11 INSTALLING DRIP EDGE, SHINGLES, METAL CAP AND SPINDLE

- 6 Bundles
- 8 Bundles
- 50 feet
- 60 feet
- 1 Pc.
- 2 Pcs.

- Shingles (not included) for 10'
- Shingles (not included) for 12'
- Drip Edge (not included) for 10'
- Drip Edge (not included) for 12'
- Metal Oval Cap
- Finial

11-A

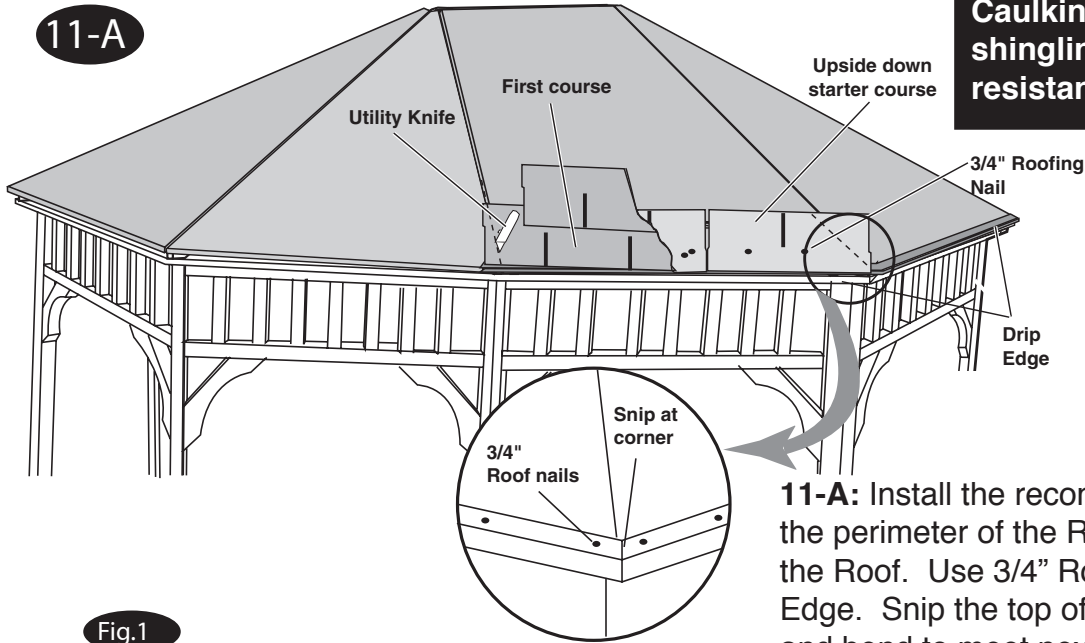

Caulking the Roof Seams before shingling will improve the water resistance of your Gazebo.

CAUTION: Use 3/4" Roofing Nails when installing layers of shingles.

11-A: Install the recommended Drip Edge around the perimeter of the Roof Panels before shingling the Roof. Use 3/4" Roofing Nails to install Drip Edge. Snip the top of the Drip Edge at corners and bend to meet next Roof Panel.

Fig.1

Making Ridge Cap

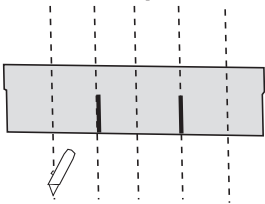

Fig.2

Cutting angle on Ridge Cap



Fig.3

Ridge Cap



Installing Ridge Cap

1" Roofing Nail on Ridge Cap

Fig.4

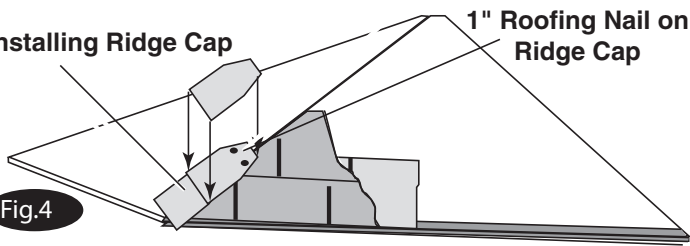

Install a starter course of Shingles consisting of a row of Shingles turned upside down. Attach with 3/4" Roofing Nails that are supplied with kit. After starter course is completed, cut excess shingles off along seam of Roof Panels with Utility Knife as shown in 11-A. Next, place first course of shingles directly over starter course in normal position and nail with 3/4" roof nails. Cut excess material off in the same manner as starter course. Continue up Roof Panel, overlapping Shingles as you go and cutting off excess.

To create Ridge Caps, take a shingle and cut it into six equal pieces as shown in Fig. 1. Cut about 1/3 of Shingle at top on an angle as shown in Fig. 2. Install Precut Ridge Caps (Fig. 3) over seams where the excess Shingle material was cut off, making sure to cover each of the angled cut ends of the Ridge Cap. Attach each Ridge Cap with two 1" roof nails supplied with kit (Fig. 4).

Fig.5

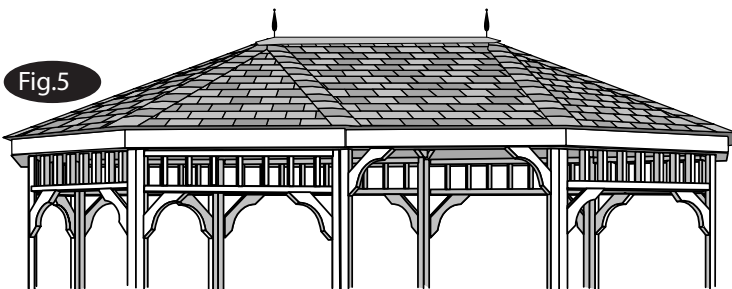

Place Metal Roof Cap on top of shingled Gazebo and install Finials through hole in cap and screw down snugly (Fig. 5). Pre-drill with 3/16" bit for dowel screw into Finial Block.

Limited Conditional Warranty*

Backyard Storage Solutions, LLC warrants the following:

1. Every product is warranted from defects in workmanship and manufacturing for one year.
2. All hardware and metal components are warranted for two years.
3. Trim is warranted for 10 years.
4. Waferboard siding and sheathing is warranted for two years.
5. SmartSide™ siding is warranted for 10 years on all Marco series buildings and 15 years on all Premier Series buildings.
6. Timber series buildings' siding and trim are warranted for 10 years.
7. Solar Shed windows are warranted for 1 year.
8. Cedar lumber is warranted for 15 years.
9. Cedar doors and Cedar Garden Center are warranted for 10 years.
10. Metal roof is warranted for 25 years.

Backyard Storage Solutions, LLC will repair, replace or pay for the affected part. In no event shall Backyard Storage Solutions, LLC pay the cost of labor or installation or any other costs related thereto. All warranties are from date of purchase. If a cash refund is paid on an affected part, it will be prorated from the date of purchase.

CONDITIONS

The warranty is effective only when:

1. The unit has been erected in accordance with the assembly instructions.
2. The unit has been properly shingled and painted or stained and reasonably and regularly maintained thereafter.
3. The failure occurs when the unit is owned by the original purchaser.
4. Backyard Storage Solutions, LLC has received the warranty registration card within thirty (30) days of purchase and notification of the failure in writing within the warranty period specified above.
5. Backyard Storage Solutions, LLC has had reasonable opportunity during the sixty (60) days following receipt of notification to inspect and verify the failure prior to commencement of any repair work.

REQUIREMENTS

Storage Buildings & Playhouses

To validate your warranty, it is necessary to properly maintain your Backyard Storage Solutions, LLC unit; shingle the roof and paint or solid-colored stain the siding using 100% acrylic latex exterior product with a minimum of two (2) coats within sixty (60) days of assembly; caulk above all doors and all horizontal and vertical trim boards; paint and seal all exposed edges, sides and faces of SmartSide™ and waferboard siding to include all exterior walls and all sides and all edges of doors.

Gazebos, Pergolas & Timber Buildings

To validate your warranty, it is necessary to properly maintain your Backyard Storage Solutions, LLC unit. This includes treating all of the exposed cedar and pine surfaces on your gazebo or timber building with an exterior grade wood preservative, an exterior oil-based semi-transparent stain, an acrylic latex exterior paint or an acrylic latex solid color exterior stain within 30 days of assembly and as needed thereafter to maintain your warranty.

Keep vegetation trimmed away from building and make sure siding panels and trim do not come in contact with masonry or cement. The minimum ground clearance for siding must be one half inch (1/2 inch) from concrete slab or two and one half inches (2 1/2 ") from the ground when building is erected or constructed on a treated wood floor kit. Water from sprinklers must be kept off unit. In no event will Backyard Storage Solutions, LLC be responsible for any indirect, incidental, consequential or special damages nor for failure(s) that are caused by events, acts or omissions beyond our control including, but not limited to, misuse or improper assembly, improper maintenance (which eventually leads to rot or decay) and acts of God. Backyard Storage Solutions, LLC will not be held responsible for any labor costs incurred to construct your unit.

This warranty gives you certain specific rights that vary from state to state.

CLAIM PROCEDURE

To make a claim under this warranty, you can either call 1-888-827-9056 or prepare a letter. Please have ready the information below when you call or include the information when writing:

1. The model and size of the product.
2. A list of the part(s) for which the claim is made.
3. Proof of purchase of the Backyard Storage Solutions, LLC item, as shown on the original invoice.
4. Run code, as listed on the yellow warranty card enclosed in the product package.

Mail the above information to:

Backyard Storage Solutions, LLC
Attn: Customer Service
1000 Ternes
Monroe, MI 48162