

16776



Call Us First!
DO NOT RETURN TO STORE.

For immediate help with assembly or product information
call our toll free number:

1-800-577-9663

or email:

customerservice@backyardproductsllc.com

Our staff is ready to provide assistance

April through October M-F 8:00 AM to 6:00 PM EST

Saturday 8:30 AM to 4:30 PM EST

November through March M - F 8:00 AM to 5:00 PM EST

USE THIS MANUAL FOR YOUR EXTENDED STATESMAN.

(This page intentionally left blank.)

ASSEMBLY MANUAL

CLASSIC STATESMAN GABLE 12' x 12' (304,8 x 365,8 cm)

	BUILDING SIZE	ACTUAL FLOOR SIZE
BASE MODEL	12' x 12' (365,8 x 365,8 cm)	12' x 12' (365,8 x 365,8 cm)
ADD ONE 12' x 4'	12' x 16' (365,8 x 487,7 cm)	12' x 16' (365,8 x 487,7 cm)
ADD ONE 12' x 8'	12' x 20' (365,8 x 609,6 cm)	12' x 20' (365,8 x 609,6 cm)
ADD ONE 12' x 4' AND ONE 12' x 8'	12' x 24' (365,8 x 731,6 cm)	12' x 24' (365,8 x 731,6 cm)

KEEP THIS MANUAL FOR FUTURE REFERENCE

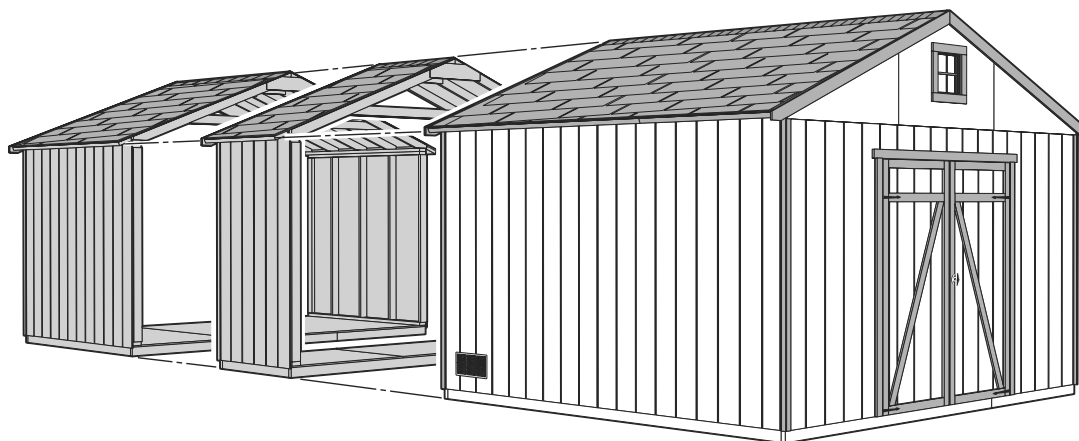

⚠ IMPORTANT! ⚠

READ INSTRUCTIONS THOROUGHLY PRIOR TO BEGINNING ASSEMBLY.

BEFORE YOU BEGIN

• **BUILDING RESTRICTIONS AND APPROVALS**

Be sure to check with local building department and homeowners association for specific restrictions and/ or requirements before building.

• **ENGINEERED DRAWINGS**

Contact our Customer Service Team if engineered drawings are needed to pull local permits.

• **SURFACE PREPARATION**

To ensure proper assembly you must build your shed on a level surface. Recommended methods and materials to level your shed are listed on page 12.

• **CHECK ALL PARTS**

Inventory all parts listed on pages 5 - 9. Contact our Customer Service Team if any parts are missing or damaged.

• **ADDITIONAL MATERIALS**

You will need additional materials to complete your shed. See pages 3 - 4 for required and optional materials and quantities.









- CUSTOMER SERVICE -







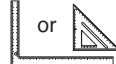

Call: 1-800-577-9663 email: customerservice@backyardproductsllc.com





TOOLS

Required

- Phillips Screwdriver 
- Drill / Driver
 - 3/8" Drill Bit
 - 1/8" Drill Bit
 - #2 Philips Drive Bit
- Hammer 
- Level 
- Pencil 
- Tape Measure 
- Square  or 

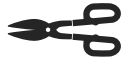
- Utility Knife 
 - Shingle Blades 
- Caulk Gun 
- Paint Tools 
- Safety Glasses 
- Ladder 
- WoodGlue 

Optional

- Tool Belt/ Nail Pouch 
- Tin Snips (for drip edge) 
- Chalk Line 
- Nail Gun
 - gun nails 
- Gloves 
- Sawsall 

Safety! Always use approved safety glasses during assembly.

HELPFUL REMINDER SYMBOLS

Look for these symbols for helpful reminders throughout this manual.



= Assistance Required; two or more people.



= Ensure squareness.



= Important required step or operation.



= Helpful assembly hint.



= Mark part with pencil.



BEGIN = Beginning of steps for assembly or installation.



FINISH = You have finished the assembly or installation.



= Level

ORIENT LUMBER AND TRIM FOR BEST APPEARANCE

Framing lumber is graded for structural strength and not appearance. Exterior trim is graded for one good side.

Always install the material leaving the best edge and best surface visible. Please remember that these blemishes in no way negatively affect the strength or integrity of our product. (See Fig. A, B, C.)

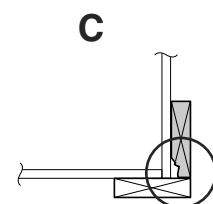
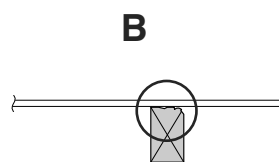
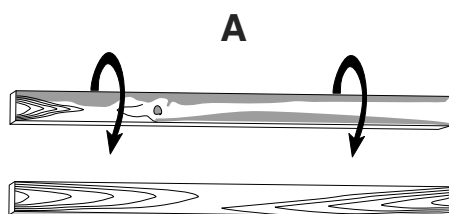

ADDITIONAL MATERIALS

FOUNDATION OR FLOOR MATERIALS

- This shed does not include any floor or leveling materials.
- See the FLOOR LEVELING section on page 12 for recommended methods and suggested materials to properly level your floor, as this will vary depending on your specific site.

REINFORCED WOOD FLOOR FRAME (OPTIONAL)

IMPORTANT! Depending on your specific use you may want to construct a heavy duty floor frame by adding additional floor joists (shown below as shaded). Below is a list of additional materials (not included):

12x12'

- x3** 2 x 4 x 12' (5,1 x 10,2 x 365,8 cm) Treated Lumber cut to 2 x 4 x 141" (5,1 x 10,2 x 358,1 cm)
- x18** 3" (7,6 cm) hot-dipped galvanized nails

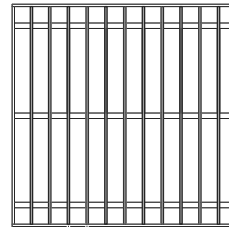

12x16'

- x4** 2 x 4 x 12' (5,1 x 10,2 x 365,8 cm) Treated Lumber cut to 2 x 4 x 141" (5,1 x 10,2 x 358,1 cm)
- x36** 3" (7,6 cm) hot-dipped galvanized nails

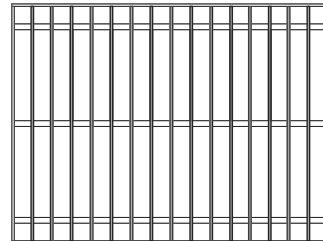

12x20'

- x5** 2 x 4 x 12' (5,1 x 10,2 x 365,8 cm) Treated Lumber cut to 2 x 4 x 141" (5,1 x 10,2 x 358,1 cm)
- x30** 3" (7,6 cm) hot-dipped galvanized nails

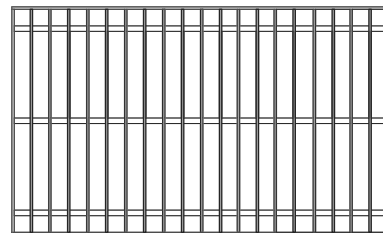

12x24'

- x6** 2 x 4 x 12' (5,1 x 10,2 x 365,8 cm) Treated Lumber cut to 2 x 4 x 141" (5,1 x 10,2 x 358,1 cm)
- x36** 3" (7,6 cm) hot-dipped galvanized nails

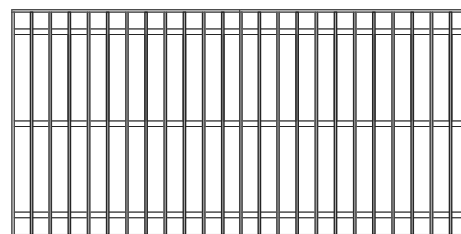

ADDITIONAL MATERIALS

COMPLETING YOUR SHED

You will need these additional materials:

	12x12'	12x16'	12x20'	12x24'	ALL SIZES
<input type="checkbox"/> 3-TAB SHINGLES (Bundles).....	7	10	12	13	<input type="checkbox"/> PAINT FOR TRIM1 Quart Use 100% acrylic latex exterior paint.
<input type="checkbox"/> PAINT FOR SIDING (Gallons)..... Use 100% acrylic latex exterior paint. (2) coats recommended.	2½	3	3	4	<input type="checkbox"/> WOOD GLUE Exterior Rated
<input type="checkbox"/> 1" GALVANIZED ROOFING NAILS(lbs). For shingles.	2	3	4	5	<input type="checkbox"/> CAULK 3 Tubes Use acrylic latex exterior caulk that is paintable.

OPTIONAL MATERIALS

	12x12'	12x16'	12x20'	12x24'
<input type="checkbox"/> DRIP EDGE (Feet).....	60'	70'	80'	90'
<input type="checkbox"/> #15 ROOFING FELT (Sq ft. to cover).....	184'	245'	306'	365'
<input type="checkbox"/> 1" GALVANIZED ROOFING NAILS(lbs).... For roofing felt.	¼	¼	½	¾









REFER TO THE BACK OF THIS MANUAL AND THE MANUFACTURER'S INSTRUCTIONS FOR INSTALLATION OF SHINGLES, DRIP EDGE AND FELT.

FLOOR PANELS (Not Included)

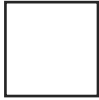
You will need floor panels and nails to complete your floor.

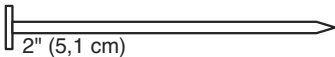
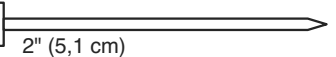
Floor panel sizes and quantities are shown below.

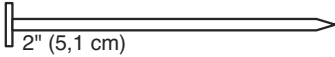
NOTE: Use a minimum of 5/8" (1,6 cm) Oriented Strand Board (OSB)

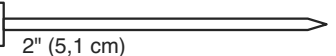
12x12'	12x20'
<input type="checkbox"/> x4  5/8" x 48" x96" (1,6 x 121,9 x 243,8 cm)	<input type="checkbox"/> x7  5/8" x 48" x 96" (1,6 x 121,9 x 243,8 cm)
<input type="checkbox"/> x1  5/8" x 48" x48" (1,6 x 121,9 x121,9 cm)	<input type="checkbox"/> x1  5/8" x 48" x48" (1,6 x 121,9 x121,9 cm)
<input type="checkbox"/> x1  2" (5,1 cm) 1 lb. of 2" (5,1 cm) Hot Dipped Galvanized Box-Type Nails.	<input type="checkbox"/> x2  2" (5,1 cm) 1 lb. of 2" (5,1 cm) Hot Dipped Galvanized Box-Type Nails.
12x16'	12x24'
<input type="checkbox"/> x6  5/8" x 48" x96" (1,6 x 121,9 x 243,8 cm)	<input type="checkbox"/> x8  5/8" x 48" x 96" (1,6 x 121,9 x 243,8 cm)
<input type="checkbox"/> x1  2" (5,1 cm) 1 lb. of 2" (5,1 cm) Hot Dipped Galvanized Box-Type Nails.	<input type="checkbox"/> x2  5/8" x 48" x48" (1,6 x 121,9 x121,9 cm)
	<input type="checkbox"/> x2  2" (5,1 cm) 1 lb. of 2" (5,1 cm) Hot Dipped Galvanized Box-Type Nails.

PARTS IDENTIFICATION AND SIZES

Double letter part identification is stamped on some parts.

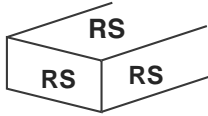

• Check these locations for part stamp.

WOOD SIZE CONVERSION CHART

Nominal Board Size	Actual Size
2" x 4".....	1-1/2" x 3-1/2" (3,8 x 8,9 cm)
1" x 4".....	3/4" x 3-1/2" (1,9 x 8,9 cm)
2" x 3".....	1-1/2" x 2-1/2" (3,8 x 6,3 cm)
1" x 3".....	3/4" x 2-1/2" (3,8 x 6,3 cm)











12x12'





GABLE 12' X 12' PARTS LIST

INVENTORY YOUR PARTS before you begin.
We suggest sorting parts by the category they are listed in.





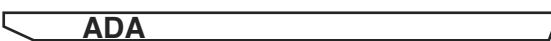



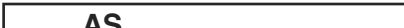

WALL

- x5  **UU** 2 x 4 x 9" (5,1 x 10,2 x 22,9 cm)
- x4  **AF** 2 x 4 x 18-1/8" (5,1 x 10,2 x 46 cm)
- x2  **SKA** 2 x 4 x 40" (5,1 x 10,2 x 101,6 cm)
- x6  **STL** 2 x 4 x 44-1/2" (5,1 x 10,2 x 113 cm)
- x5  **SP** 2 x 4 x 48" (5,1 x 10,2 x 121,9 cm)
- x1  **AM** 2 x 4 x 67" (5,1 x 10,2 x 170,2 cm)
- x2  **UM** 2 x 4 x 68" (5,1 x 10,2 x 172,7 cm)
- x23  **AI** 2 x 4 x 78-1/2" (5,1 x 10,2 x 199,4 cm)
- x6  **TJ** 2 x 4 x 92-1/2" (5,1 x 10,2 x 235 cm)
- x4  **TP** 2 x 4 x 96" (5,1 x 10,2 x 243,9 cm)

RAFTERS



- x12  6 x 24" (15,2 x 61 cm)
- x14  **ADA** 2 x 4 x 77-15/16" (5,1 x 10,2 x 198 cm)
- x2  **TP** 2 x 4 x 96" (5,1 x 10,2 x 243,9 cm)

TRIM

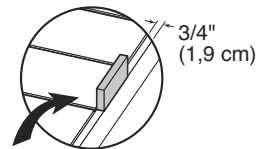
- x2  **AS** 2 x 6 x 49-1/2" (5,1 x 15,2 x 125,8 cm)
- x2  **VX** 2 x 6 x 96" (5,1 x 15,3 x 243,9 cm)
- x4  3/8 x 1-3/4 x 81-1/2" (1 x 4,5 x 207 cm)
- x4  3/8 x 1-3/4 x 83-1/2" (1 x 4,5 x 212,1 cm)
- x2  **WYR** 19/32 x 4 x 85-3/16" (1,51 x 10,2 x 216,4 cm)
- x2  **WYL** 19/32 x 4 x 85-3/16" (1,51 x 10,2 x 216,4 cm)
- x1  **ZJ** 5/8 x 3 x 72" (1,6 x 7,6 x 182,9 cm)
- x2  **DI** 5/8 x 3 x 12" (1,6 x 7,6 x 30,5 cm)
- x2  **EU** 5/8 x 3 x 17" (1,6 x 7,6 x 43,2 cm)
- x1  **GAA** 1 x 3 x 5" (2,5 x 7,6 x 12,7 cm) **ONE USED AS A GAUGE BLOCK FOR 3/4" (1,9 cm) MEASUREMENT**

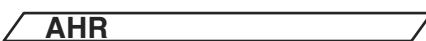
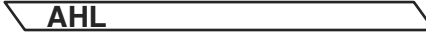

DOOR

- x2  **AH** 5/8 x 3 x 26-5/8" (1,6 x 7,6 x 67,7 cm)
- x1  **AHR** 5/8 x 3 x 62" (1,6 x 7,6 x 157,5 cm)
- x1  **AHL** 5/8 x 3 x 62" (1,6 x 7,6 x 157,5 cm)
- x2  **OO** 2 x 3 x 69" (5,1 x 7,6 x 175,3 cm) Finger Jointed

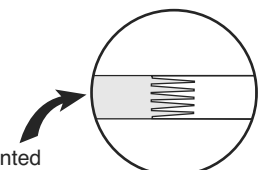

WALL PANEL & DOORS PARTS LIST

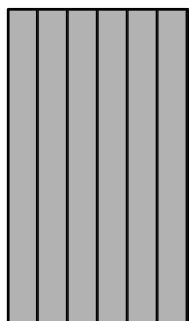

x9 3/8 x 48 x 84"
(1 x 121,9 x 213,4 cm)

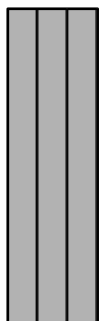

x2 3/8 x 23-7/8 x 84"
(1 x 60,7 x 213,4 cm)

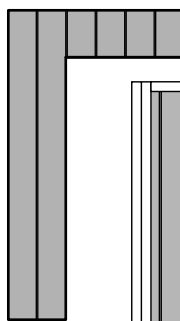

x1

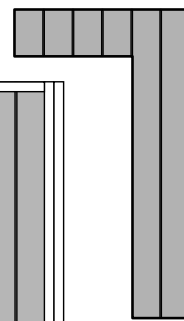

x1

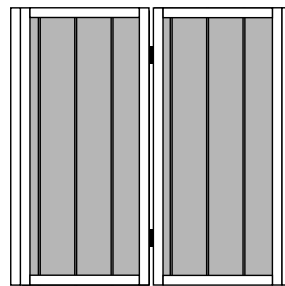

x1

LEFT DOOR

x1

RIGHT DOOR

NOTE: Panel parts are not stamped with part identification.

GABLE PANELS



x2 3/8 x 23-9/16 x 48"
(1 x 59,9 x 121,9 cm)

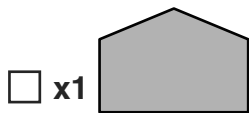

x1 3/8 x 33-1/2 x 48"
(1 x 86 x 121,9 cm)

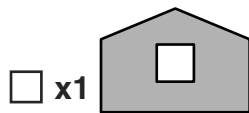

x1 3/8 x 33-1/2 x 48"
(1 x 86 x 121,9 cm)



x2 3/8 x 23-9/16 x 48"
(1 x 59,9 x 121,9 cm)

ROOF PANELS

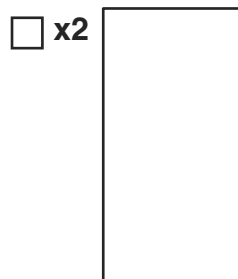

x2 48" x 96"
(121,9 x 243,8 cm)

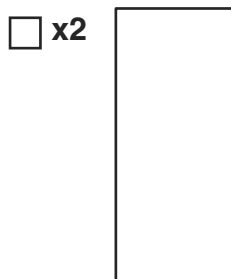

x2 36-1/2" x 96"
(92,7 x 243,8 cm)

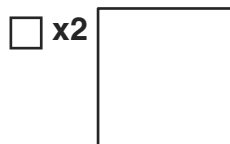

x2 47-7/8" x 48"
(121,6 x 121,9 cm)

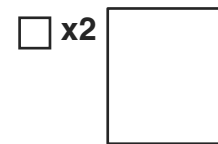

x2 36-1/2" x 47-7/8"
(92,7 x 121,9 cm)

**Roof panels are
7/16" (1,1 cm) thick.**

LOFT PARTS LIST



x1 **NK**
2 x 3 x 48" (5,1 x 7,6 x 121,9 cm)



x1 **PT**
2 x 3 x 96" (5,1 x 7,6 x 243,8 cm)



x2 **SP**
2 x 4 x 48" (5,1 x 10,2 x 121,9 cm)



x2 **TP**
2 x 4 x 96" (5,1 x 10,2 x 243,8 cm)



x1
23-7/8" x 40-7/8" (60,7 x 103,8 cm)



x1
23-7/8" x 96" (60,7 x 243,8 cm)

**Loft panels are
7/16" (1,1 cm) thick.**

SHELVING PARTS LIST

x14 **AC**

2 x 3 x 10"
(5,1 x 7,6 x 25,4 cm)

x2 **WJ**

1 x 4 x 48"
(2,5 x 10,2 x 243,9 cm)

x14 

3/8 x 3 x 12-1/2"
(1 x 7,6 x 32 cm)

x2 **KP**

1 x 4 x 96"
(2,5 x 10,2 x 243,9 cm)

x2 

3/8 x 11-1/4 x 47-7/8"
(1 x 28,6 x 121,6 cm)





**Shelf panels
are 7/16"
(1,1 cm) thick.**

x2 

3/8 x 11-1/4 x 96"
(1 x 28,6 x 243,9 cm)

NAIL BOXES (Shown Actual Size)



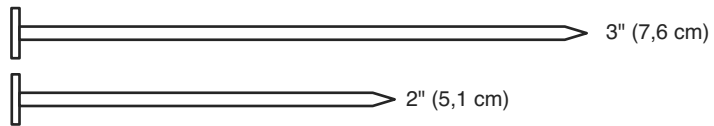

12x12' 12x16' 12x20' 12x24'

				
BOXES	4	5	5	6
BOXES	6	7	7	8



FASTENER/HARDWARE BAG (Shown Actual Size)

12x12' 12x16' 12x20' 12x24'

				
	110	110	110	110
	83	91	99	107
	23	23	23	23
	62	88	94	105
	74	74	74	74

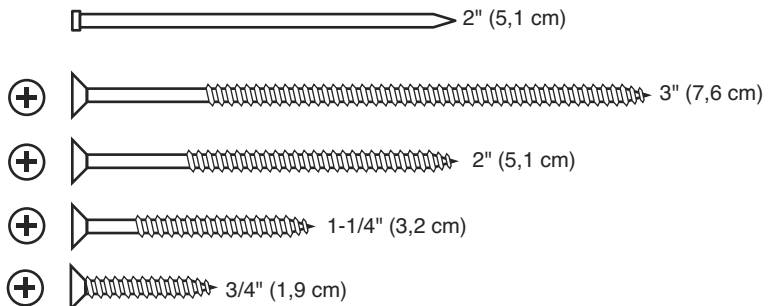

Other HARDWARE (Not Actual Size)

x4 

x1  12" x 12"
(30,5 x 30,5 cm)

x12  3/4" (1,9 cm) Black / Bagged separately

x1 

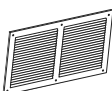
x2  16" x 8" (40,6 x 20,3 cm)

x2  1-1/2" (3,8 cm)

x12  1/2" (1,3 cm)

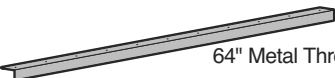
x1  64" Metal Threshold

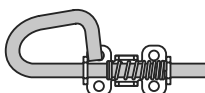
x2 

x11  3/4" (1,9 cm) Special coating / Bagged separately

x4  1" (2,5 cm)

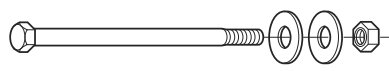
x2  3/8" LOFT HDW. SET:
5-1/2" (13,98 cm) Hex bolt,
2 flat washers, lock nut

PARTS IDENTIFICATION AND SIZES

Part identification is stamped on some parts.

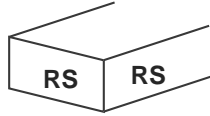

• Check these locations for part stamp.

WOOD SIZE CONVERSION CHART

Nominal Board Size	Actual Size
2" x 4".....	1-1/2" x 3-1/2" (3,8 x 8,9 cm)
1" x 4".....	3/4" x 3-1/2" (1,9 x 8,9 cm)
2" x 3".....	1-1/2" x 2-1/2" (3,8 x 6,3 cm)
1" x 3".....	3/4" x 2-1/2" (3,8 x 6,3 cm)

12x4'





GABLE 12' x 4' EXTENDER KIT PARTS LIST

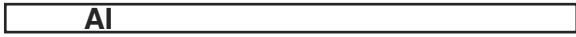

INVENTORY YOUR PARTS before you begin.

We suggest sorting parts by the category they are listed in.

WALL

- x2  2 x 4 x 48" (5,1 x 10,2 x 121,9 cm)
- x4  2 x 4 x 78-1/2" (5,1 x 10,2 x 199,4 cm)
- x4  2 x 4 x 94-1/2" (5,1 x 10,2 x 240 cm)
- x1  2 x 4 x 96" (5,1 x 10,2 x 243,9 cm)

RAFTERS

- x4  6 x 24" (15 x 61 cm)
- x4  2 x 4 x 77-15/16" (5,1 x 10,2 x 198 cm)



TRIM

- x2  2 x 6 x 48" (5,2 x 15,2 x 121,9 cm)

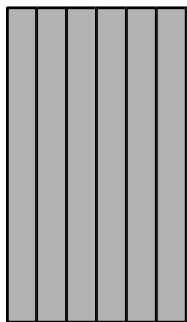
WALL PANELS

- x2  3/8 x 48 x 84"
(1 x 121,9 x 213,4 cm)

ROOF PANELS

- x2  7/16 x 47-7/8 x 48"
(1,1 x 121,6 x 121,9 cm)
- x2  7/16 x 36-1/2 x 47-7/8"
(1,1 x 92,7 x 121,6 cm)

Roof panels are 7/16" (1,1 cm) thick.

PARTS IDENTIFICATION AND SIZES

Part identification is stamped on some parts.

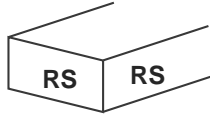

• Check these locations for part stamp.

Nominal Board Size	Actual Size
2" x 4"	1-1/2" x 3-1/2" (3,8 x 8,9 cm)
1" x 4"	3/4" x 3-1/2" (1,9 x 8,9 cm)
2" x 3"	1-1/2" x 2-1/2" (3,8 x 6,3 cm)
1" x 3"	3/4" x 2-1/2" (3,8 x 6,3 cm)

12x8'



GABLE 12' x 8' EXTENDER KIT PARTS LIST

INVENTORY YOUR PARTS before you begin.

We suggest sorting parts by the category they are listed in.

WALL

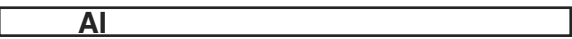
x8 **AI**  2 x 4 x 78-1/2" (5,1 x 10,2 x 199,4 cm)

x8 **TP**  2 x 4 x 96" (5,1 x 10,2 x 243,9 cm)

RAFTERS

x8  6 x 24" (15,2 x 61 cm)

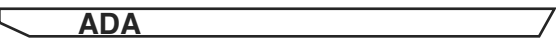
x8 **ADA**  2 x 4 x 77-15/16" (5,1 x 10,2 x 198 cm)

TRIM

x2 **VX**  2 x 6 x 96" (5,2 x 15,2 x 243,9 cm)

WALL PANELS

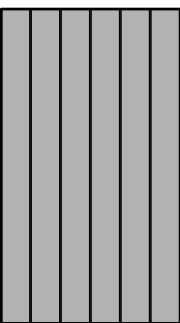
x4  3/8 x 48 x 84" (1 x 121,9 x 213,4 cm)

ROOF PANELS

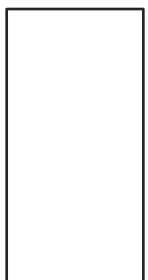
x2  7/16 x 48 x 96" (1,1 x 121,9 x 243,9 cm)

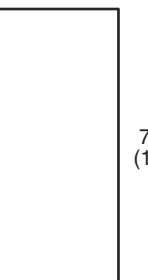
x2  7/16 x 36-1/2 x 96" (1,1 x 92,71 x 243,9 cm)

Roof panels are 7/16" (1,1 cm) thick.

INSTRUCTION MANUAL LAYOUT



TABS ARE DISPLAYED AT THE OUTSIDE EDGE OF INSTRUCTION PAGES TO IDENTIFY MODEL SIZE.



Use tabs to make sure you are following the correct instructions.

GABLE 12' x 12'

GABLE 12' x 12' :

Look for this tab throughout instructions.



If tab is not displayed, skip to next page including 12' x 12' tab.

GABLE 12' x 12'

GABLE 12' x 16'

GABLE 12' x 16' :

Look for this tab throughout instructions.

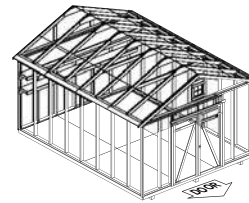

If tab is not displayed, skip to next page including 12' x 16' tab.

GABLE 12' x 16'

GABLE 12' x 20'

GABLE 12' x 20' :

Look for this tab throughout instructions.

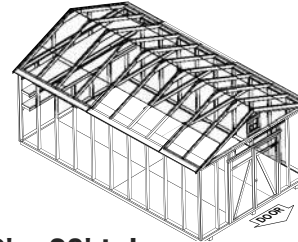

If tab is not displayed, skip to next page including 12' x 20' tab

GABLE 12' x 20'

GABLE 12' x 24'

GABLE 12' x 24' :

Look for this tab throughout instructions.

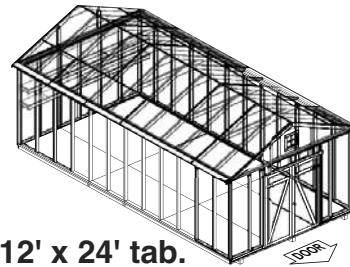

If tab is not displayed, skip to next page including 12' x 24' tab.

GABLE 12' x 24'



IF ALL TABS ARE DISPLAYED, FOLLOW ALL INSTRUCTIONS REGARDLESS OF MODEL SIZE.



NOTE: GABLE 12' x 12' image shown standard on pages applicable to all sizes.

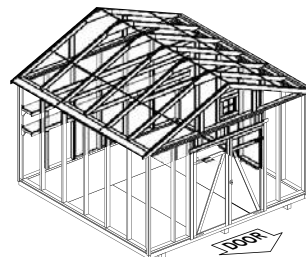

CONCRETE FOUNDATION

If you choose to install your kit on a concrete slab refer to the diagram below.
Attach the sill plates on the foundation as shown, and continue on to page 12.

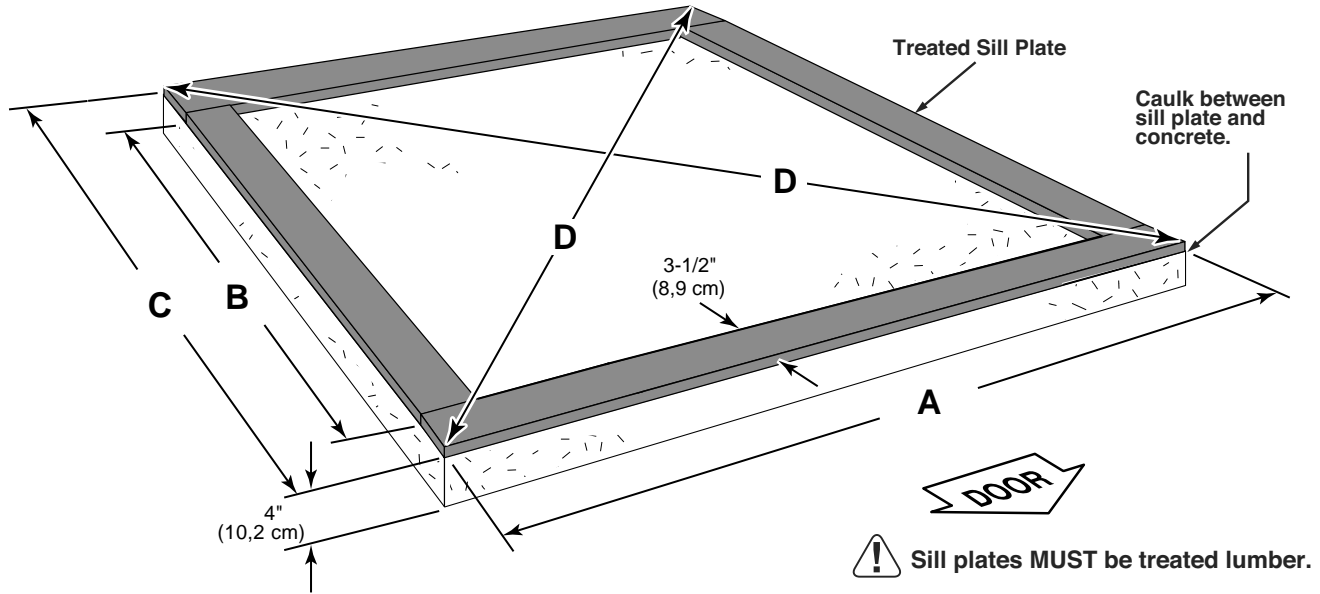

Building Size	Actual Floor Size	A	B	C	D
12'x 12' (365,8 x 365,8 cm)	12'x 12' (365,8 x 365,8 cm)	144" (365,8 cm)	137" (348 cm)	144" (365,8 cm)	203-5/8" (517,3 cm)

12' x 12' Building Requires:

x4 2 x 4 x12' (5,1 x 10,2 x 365,8 cm)

x1 Caulk

Building Size	Actual Floor Size	A	B	C	D
12'x 16' (365,8 x 487,7 cm)	12'x 16' (365,8 x 487,7 cm)	144" (365,8 cm)	185" (469,9 cm)	192" (487,7 cm)	240" (609,6 cm)

12' x 16' Building Requires:

x2 2 x 4 x12' (5,1 x 10,2 x 365,8 cm) x2 2 x 4 x 16' (5,1 x 10,2 x 487,7 cm)

x1 Caulk

Building Size	Actual Floor Size	A	B	C	D
12'x 20' (365,8 x 609,6 cm)	12'x 20' (365,8 x 609,6 cm)	144" (365,8 cm)	233" (591,9 cm)	240" (609,6 cm)	279-7/8" (710,9 cm)

12' x 20' Building Requires:

x2 2 x 4 x12' (5,1 x 10,2 x 365,8 cm) x2 2 x 4 x 16' (5,1 x 10,2 x 487,7 cm)

x2 Caulk x1 2 x 4 x 8' (5,1 x 10,2 x 244 cm)

Building Size	Actual Floor Size	A	B	C	D
12'x 24' (365,8 x 609,6 cm)	12'x 24' (365,8 x 609,6 cm)	144" (365,8 cm)	281" (713,8 cm)	288" (731,6 cm)	322" (817,9 cm)

12' x 24' Building Requires:

x2 2 x 4 x12' (5,1 x 10,2 x 365,8 cm) x2 2 x 4 x 16' (5,1 x 10,2 x 487,7 cm)

x3 Caulk x2 2 x 4 x 8' (5,1 x 10,2 x 244 cm)

⚠ Allow new concrete slabs to cure for at least seven (7) days.

- A treated 2 x 4" (5,1 x 10,2 cm) sill plate is required when installing your shed on concrete. Purchase full length treated lumber, or butt shorter pieces end-to-end and seal seams with caulk.
- Use a high quality exterior grade caulk beneath all sill plates.
- Fasten 2 x 4" (5,1 x 10,2 cm) sill plates to slab using approved concrete anchors (fasteners not included).
- Check local code for concrete foundation requirements.

OPTIONAL WOOD FRAME FLOOR LEVELING OPTIONS

There are multiple ways to level your floor frame. Our recommended leveling method is shown below.
Leveling materials are not included in this kit.

PREFERRED METHOD - 4x4 TREATED RUNNERS (Typical for 12' x 12' Kit)

Runners are generally 12" (30,5 cm) from ends of floor frame and under seams.

Measurements to centers of 4x4's.

- 3" Screws angled into 4x4.
- (2) at each point frame and 4x4 touch.

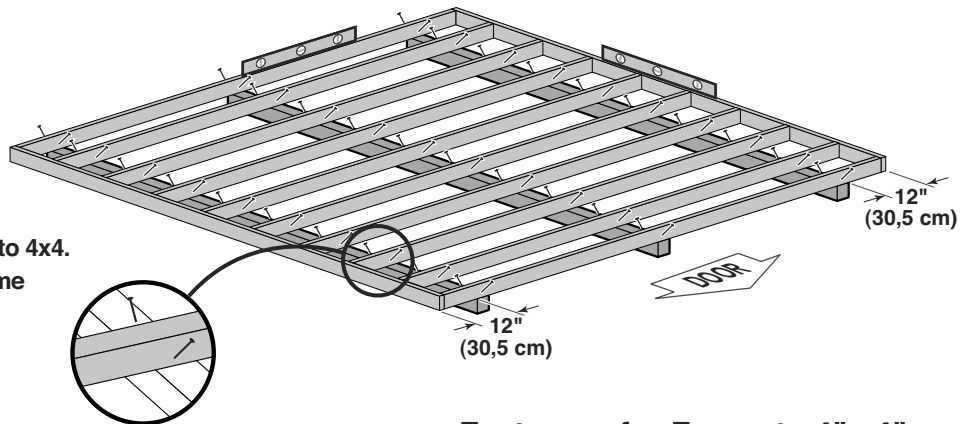





! FLOOR FRAME NOT INCLUDED

Fig. B

Fasteners for Frame to 4"x 4".
(3" Screws shown as one option.)
Minimum 3" screws / exterior grade.

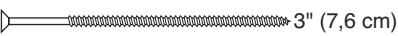
MATERIAL REQUIRED

12' x 12'	<input type="checkbox"/> x3 4" x 4" x 12' (10,2 x 10,2 x 305 cm) Treated Lumber	<input type="checkbox"/> x60  3" (7,6 cm)
12' x 16'	<input type="checkbox"/> x3 4" x 4" x 16' (10,2 x 10,2 x 487,7 cm) Treated Lumber	<input type="checkbox"/> x78  3" (7,6 cm)
12' x 20'	<input type="checkbox"/> x6 4" x 4" x 10' (10,2 x 10,2 x 304,8 cm) Treated Lumber	<input type="checkbox"/> x96  3" (7,6 cm)
12' x 24'	<input type="checkbox"/> x6 4" x 4" x 12' (10,2 x 10,2 x 305 cm) Treated Lumber	<input type="checkbox"/> x144  3" (7,6 cm)

! Use only wood treated for ground contact and fasteners approved for use with treated wood.

! Always support frame seams.

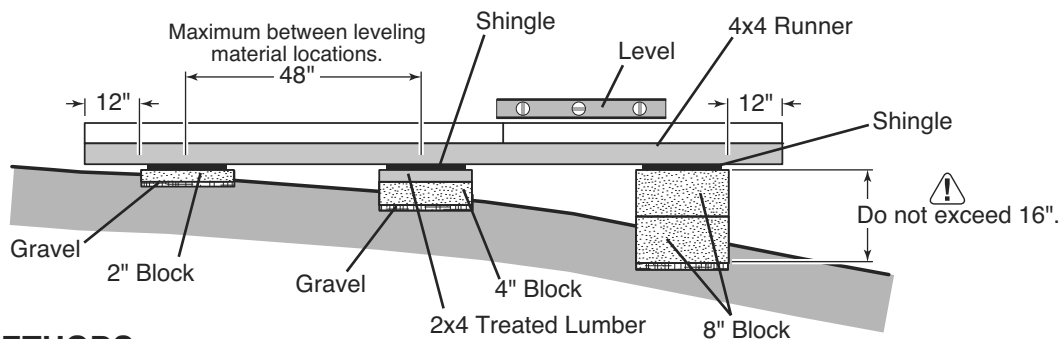

LEVELING METHODS

- Level under 4x4 runners only.
- Locate leveling material 12" from ends of runners and no more than 48" apart.
- Asphalt shingles should be used between 4x4 runners and blocks or treated lumber. Never use shingles in direct contact with ground.
- For best results and aiding in water drainage use gravel under each concrete block.

LEVELING MATERIALS

- Gravel
- Solid Masonry Blocks in 1", 2", 4" or 8" thickness
- 2x4 Treated Lumber
- Asphalt Shingles

! Leveling higher than 16" not recommended.

LEVELING & SQUARING A 12 x 12' FLOOR FRAME (Not Included)



- FOR 12' x 16', SKIP TO PAGE 14
- FOR 12' x 20', SKIP TO PAGE 15.
- FOR 12' x 24', SKIP TO PAGE 16.



LEVEL AND SQUARE FLOOR FRAME



Before attaching floor decking, it is important to level and square the floor frame. A level and square floor frame is required to correctly construct your shed.

✓ BEGIN

- 1 See page 12 for the preferred floor leveling method.
- 2 Use level and check the frame is level before applying floor panels.
- 3 Check for frame squareness by measuring diagonally across corners. If the measurements are the same, the frame is square. The diagonal measurement will be approximately **203-5/8" (517,3 cm)**.
- 4 When the frame is level and square, secure one side of frame to 4x4 runners using one fastener at ends of each runner. At the opposite end of the frame, secure the frame to 4x4 runners with one fastener at ends of each runner making sure the frame remains square (**Fig. A**).



FINISH

- 5 Once the floor frame is level and square fasten the frame at each point the frame contacts the 4x4 runners (**Fig. B**). Go to page 17.

Runners are generally 12" (30,5 cm) from ends of floor frame and under seams.

- 3" Screw angled into 4x4.
- (2) at each point frame and 4x4 touch.

First, secure at ends with one fastener.

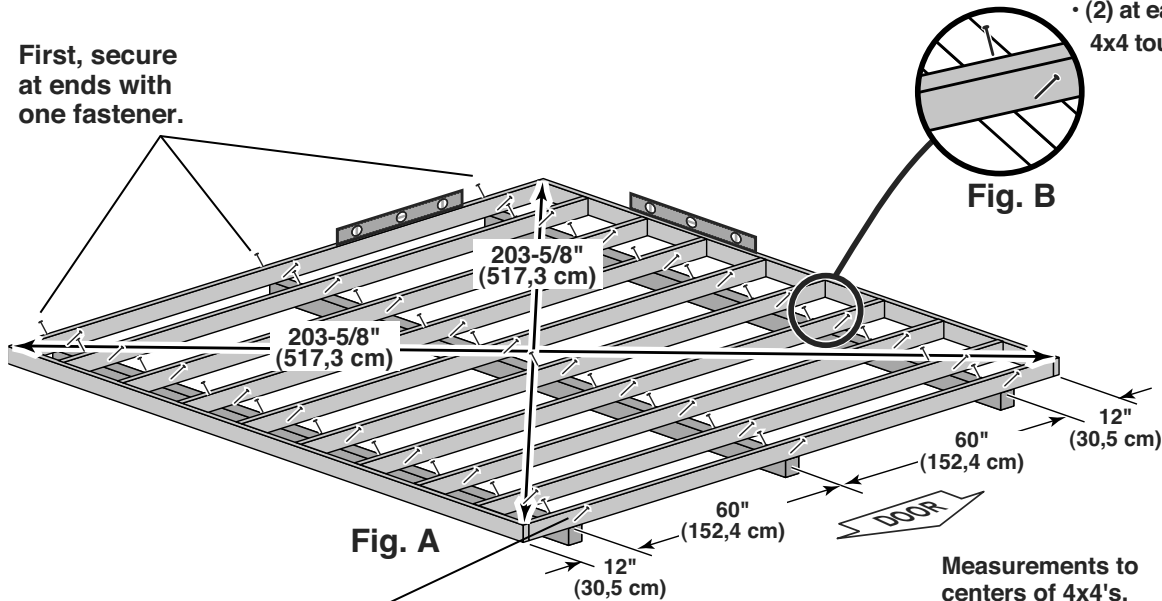

Second, secure at ends with one fastener.

GABLE 12' x 12'

LEVELING & SQUARING A 12 x 16' FLOOR FRAME (Not Included)

STOP!



LEVEL AND SQUARE FLOOR FRAME



STOP!

Before attaching floor decking, it is important to level and square the floor frame. A level and square floor frame is required to correctly construct your shed.

✓ **BEGIN**

- 1 ⚠ See page 12 for the preferred floor leveling method.
- 2 Use level and check the frame is level before applying floor panels.
- 3 Check for frame squareness by measuring diagonally across corners. If the measurements are the same, the frame is square. The diagonal measurement will be approximately **240" (609,6 cm)**.
- 4 When the frame is level and square secure one side of frame to the 4x4 runners using one fastener at ends of each runner. At the opposite end of the frame, secure the frame to 4x4 runners with one fastener at ends of each runner making sure the frame remains square (**Fig. A**).



FINISH

- 5 Once the floor frame is level and square fasten the frame at each point the frame contacts the 4x4 runners (**Fig. B**). **Go to page 17.**

GABLE 12' x 16'

Runners are generally 12" (30,5 cm) from ends of floor frame and under seams.

First, secure at ends with one fastener.

- 3" Screws angled into 4x4.
- (2) at each point frame and 4x4 touch.

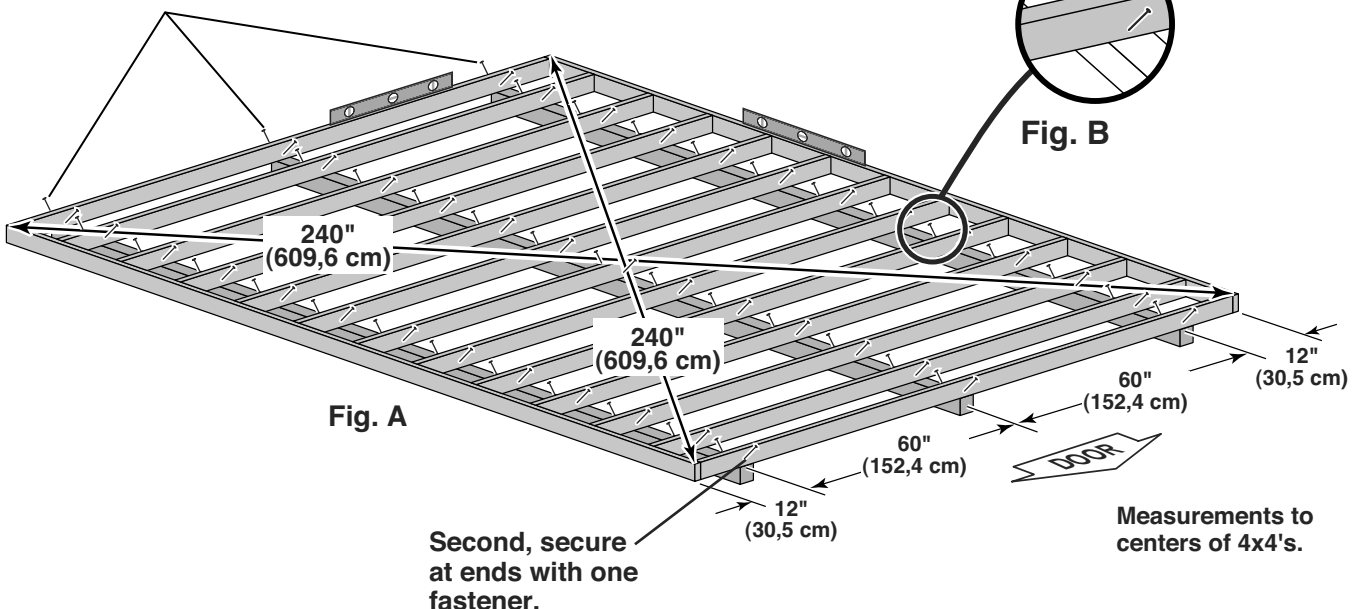

LEVELING & SQUARING A 12 x 20' FLOOR FRAME (Not Included)

STOP!



LEVEL AND SQUARE FLOOR FRAME



STOP!

Before attaching floor decking, it is important to level and square the floor frame. A level and square floor frame is required to correctly construct your shed.

✓ **BEGIN**

- 1 See page 12 for the preferred floor leveling method.
- 2 Use level and check the frame is level before applying floor panels.
- 3 Check for frame squareness by measuring diagonally across corners. If the measurements are the same, the frame is square. The diagonal measurement will be approximately **279-7/8" (710,9 cm)**.
- 4 When the frame is level and square secure one side of frame to the 4x4 runners using one fastener at ends of each runner. At the opposite end of the frame, secure the frame to 4x4 runners with one fastener at ends of each runner making sure the frame remains square (**Fig. A**).



FINISH

- 5 Once the floor frame is level and square fasten the frame at each point the frame contacts the 4x4 runners (**Fig. B**). **Go to page 17.**

Runners are generally 12" (30,5 cm) from ends of floor frame and under seams.

First, secure at ends with one fastener.

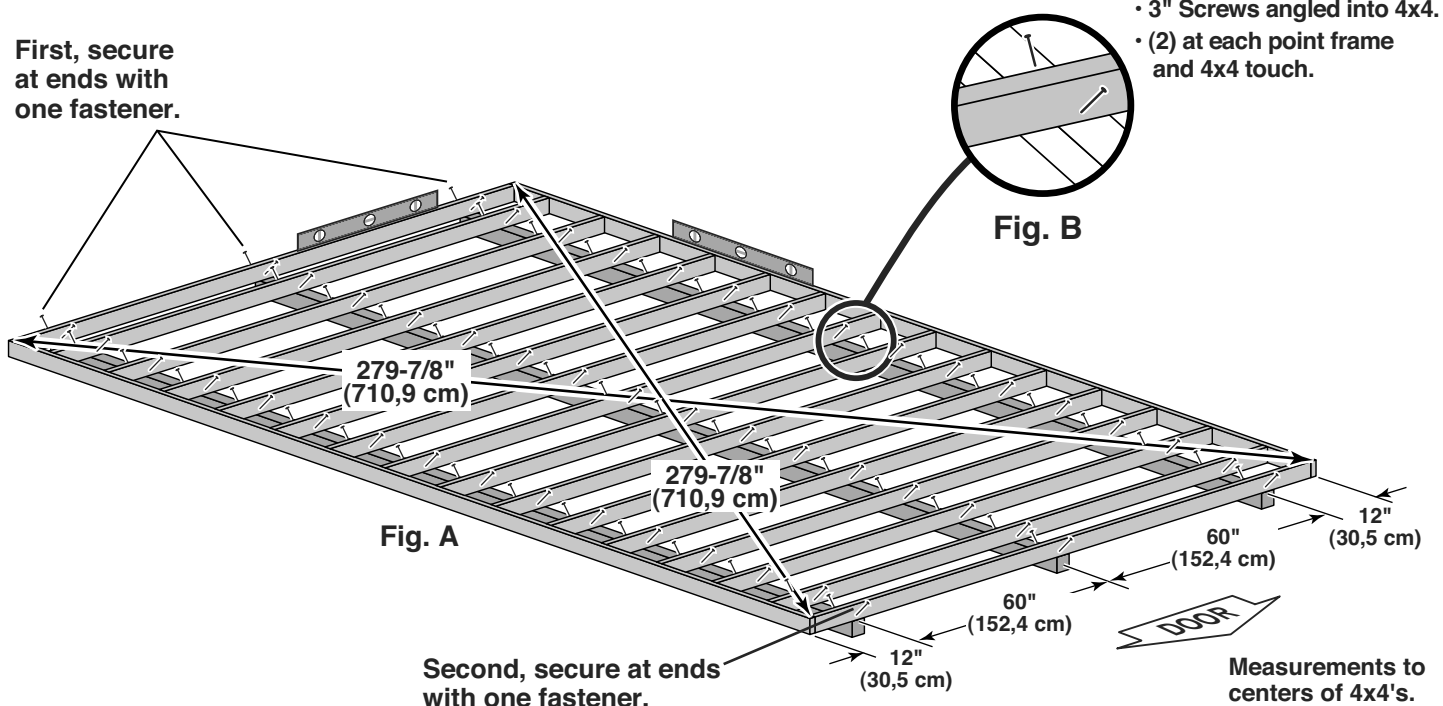

LEVELING & SQUARING A 12 x 24' FLOOR FRAME (Not Included)

STOP!



LEVEL AND SQUARE FLOOR FRAME



STOP!

Before attaching floor decking, it is important to level and square the floor frame. A level and square floor frame is required to correctly construct your shed.

BEGIN

- 1 See page 12 for the preferred floor leveling method.
- 2 Use level and check the frame is level before applying floor panels.
- 3 Check for frame squareness by measuring diagonally across corners. If the measurements are the same, the frame is square. The diagonal measurement will be approximately **322" (817,9 cm)**.
- 4 When the frame is level and square secure one side of frame to the 4x4 runners using one fastener at ends of each runner. At the opposite end of the frame, secure the frame to 4x4 runners with one fastener at ends of each runner making sure the frame remains square (**Fig. A**).

FINISH

- 5 Once the floor frame is level and square fasten the frame at each point the frame contacts the 4x4 runners (**Fig. B**). Go to page 17.

Runners are generally 12" (30,5 cm) from ends of floor frame and under seams.

First, secure at ends with one fastener.

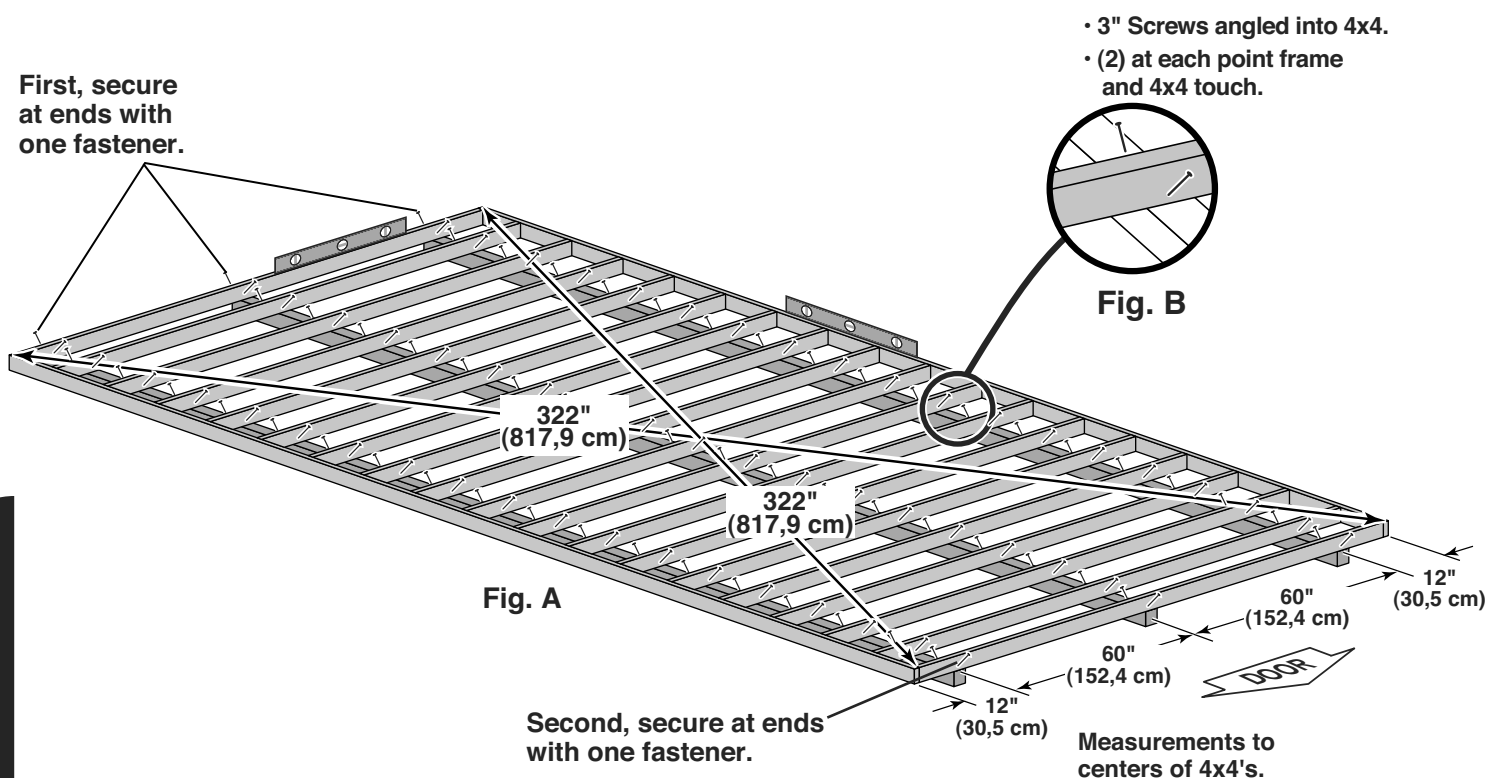

GABLE 12' x 24'

! IMPORTANT!

NOTE: GABLE 12' x 12' shown standard throughout manual



Check the floor frame is level after installing floor panels. Re-level if needed.

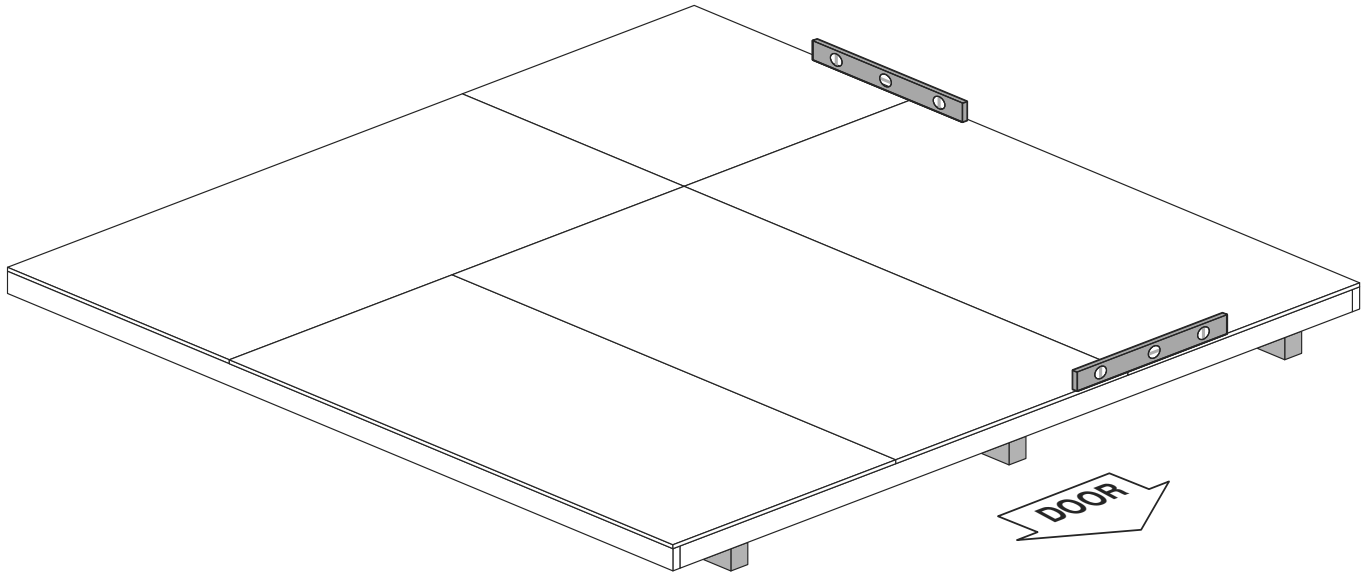

GABLE 12' x 12'

GABLE 12' x 16'

GABLE 12' x 20'

GABLE 12' x 24'



• The floor should be used as a stable work surface for wall construction.

HINT: • Organize your assembly procedure during the build process to avoid over-handling of the walls.

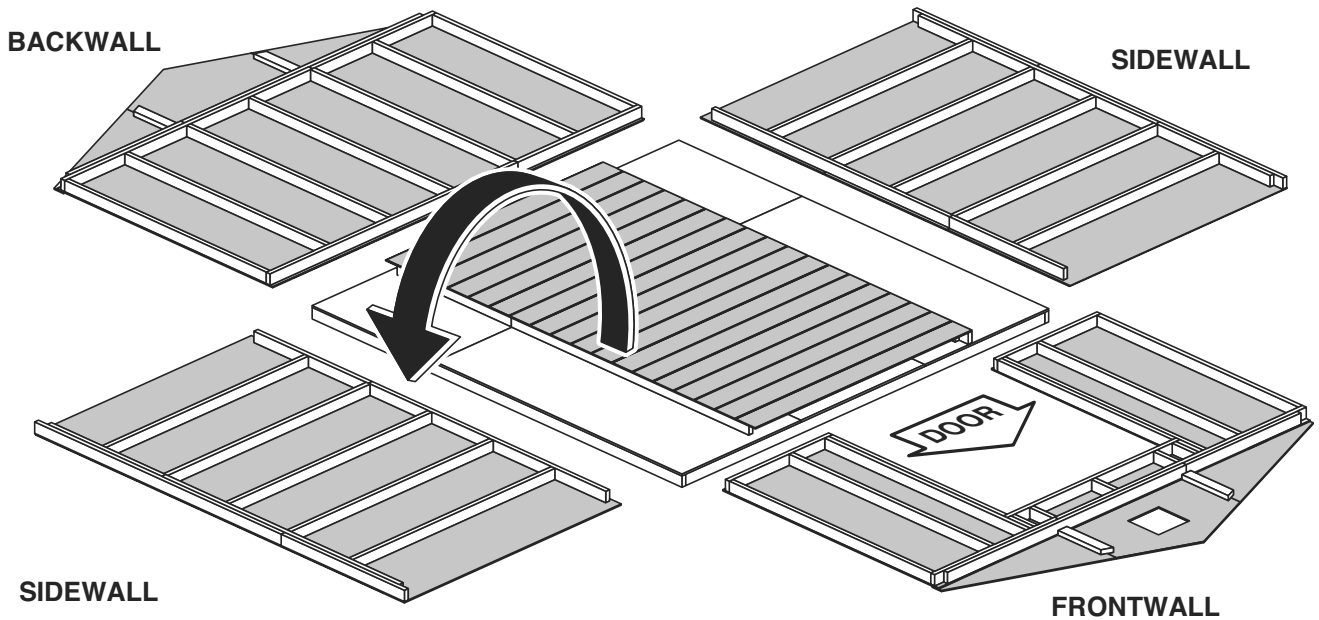

BACK WALL FRAME

PARTS REQUIRED:

x2 **SP**
2 x 4 x 48" (5,1 x 10,2 x 121,9 cm)

x7 **AI**
2 x 4 x 78-1/2" (5,1 x 10,2 x 199,4 cm)

x2 **TP**
2 x 4 x 96" (5,1 x 10,2 x 243,8 cm)

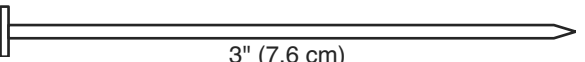
x32  3" (7,6 cm)

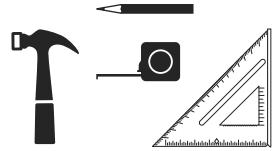

✓ **BEGIN**

1 Orient parts on edge on floor as shown.

2 Use two 3" nails at each connection (**Fig. A**) and four 3" nails at seams (**Fig. B**).

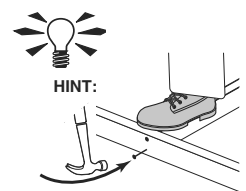
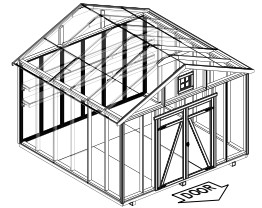

GABLE 12' x 12'

GABLE 12' x 16'

GABLE 12' x 20'

GABLE 12' x 24'

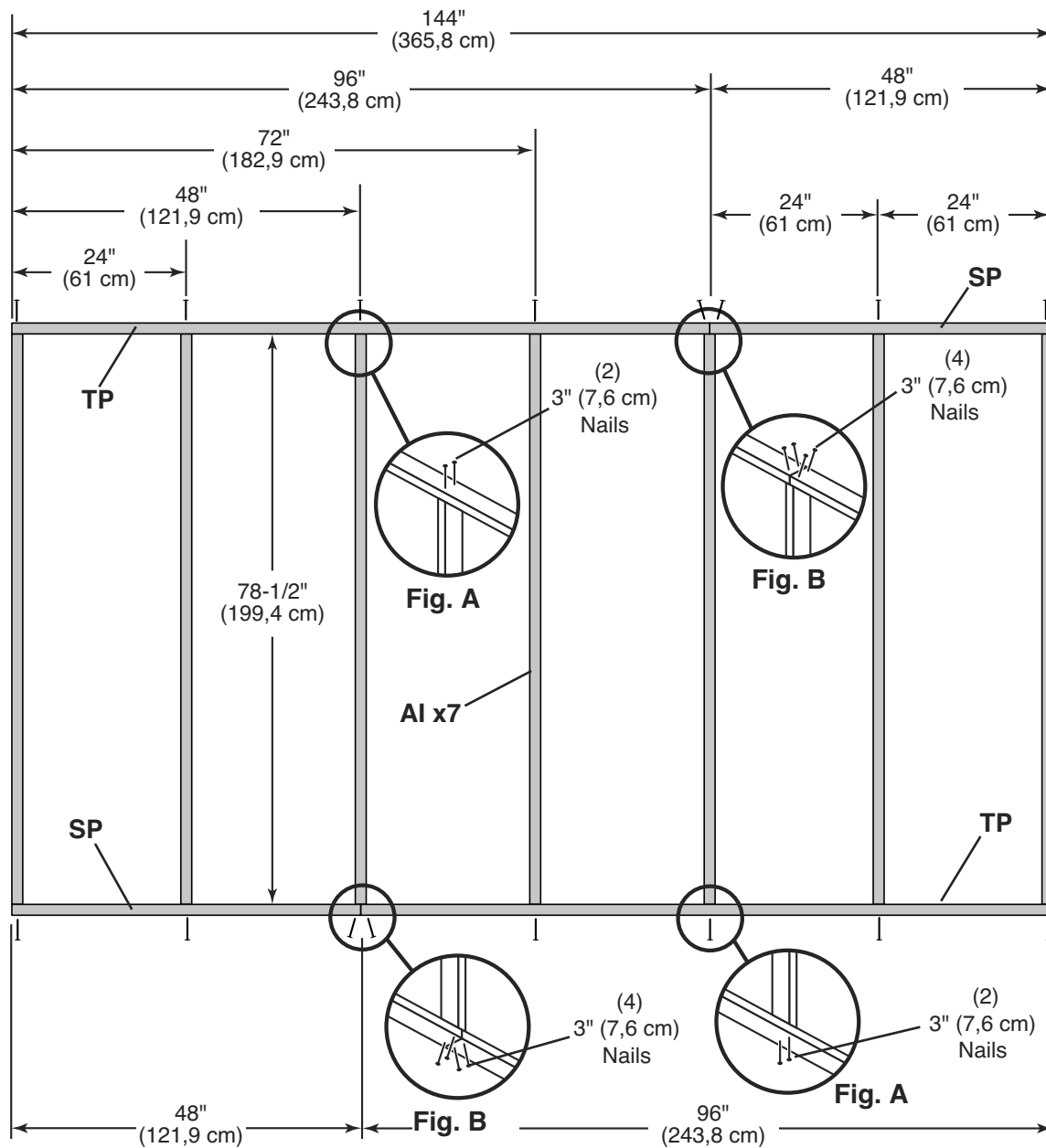

BACK WALL PANELS

PARTS REQUIRED:

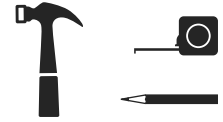
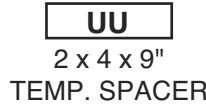
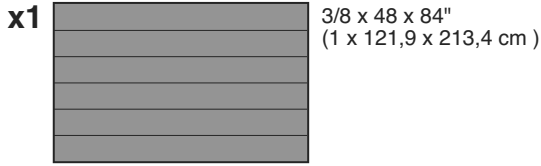
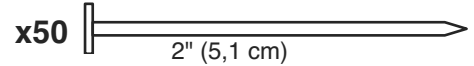

Ensure your wall frame is square by installing one panel and squaring frame.

BEGIN

1 Place LEFT panel onto wall frame with primed side up as shown.

Locate the panel 1-1/2" above the top plate. Use **UU** as a gauge block for the 1-1/2" top overhang measurement. Use **GAA** as a gauge block to mark the 3/4" side measurement on the wall stud. Secure panel with two 2" nails in the corners (**Fig. A**).

2 Move to the opposite end. Using the long edge of the panel as a lever, move the panel side-to-side until you have a 3/4" measurement on the wall stud. Secure corner with two 2" nails (**Fig. B**).

3 Nail the panel using 2" nails 6" apart on edges and 12" apart inside panel.

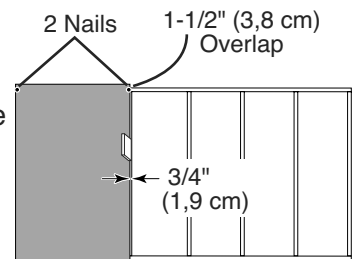
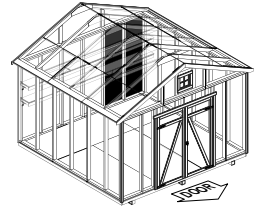

Fig. A

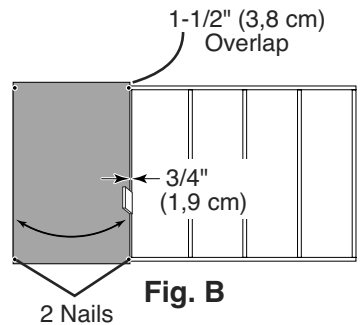
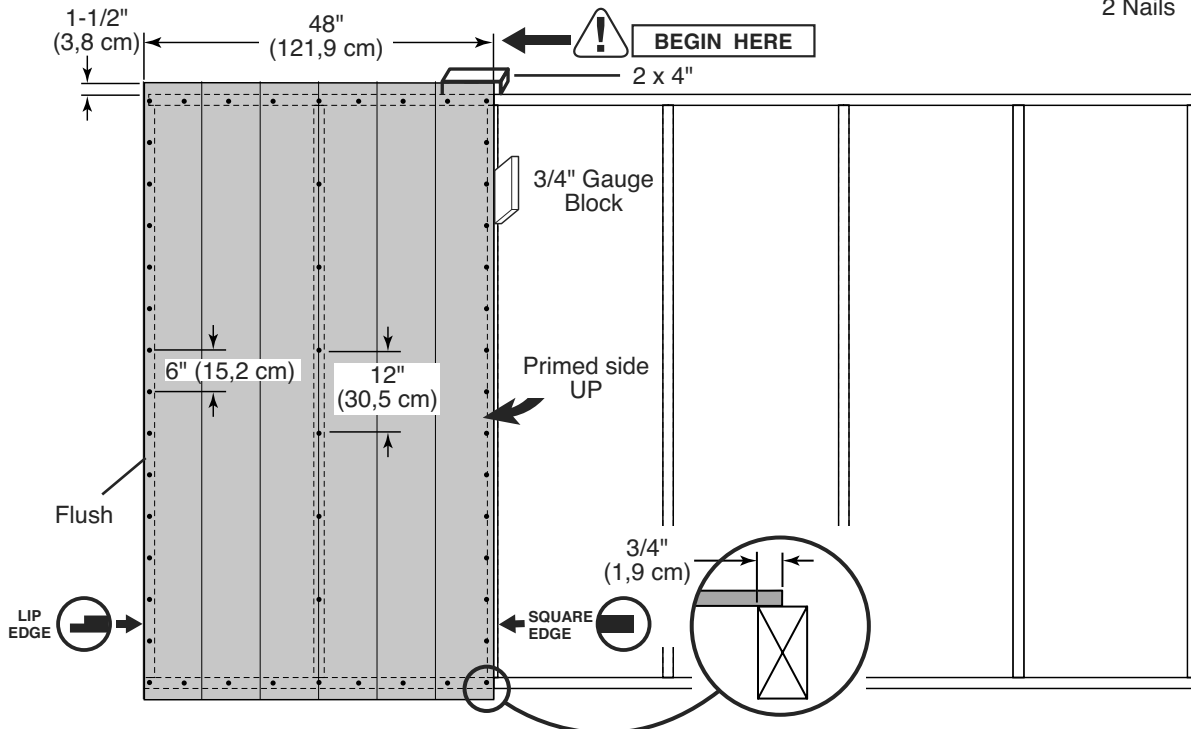

Fig. B

For squareness maintain 3/4" and 1-1/2" measurement along panel edge.



BACK WALL PANELS

PARTS REQUIRED:

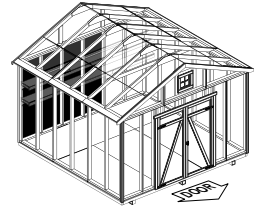
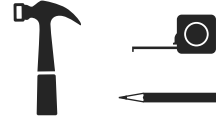
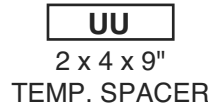
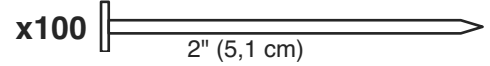
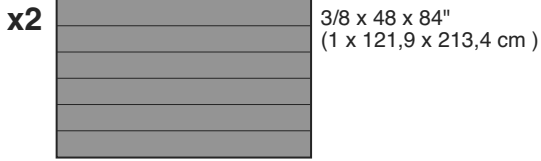

4 Place MIDDLE panel on frame as shown with primed side facing up flush with first panel. Nail using 2" nails 6" apart on edges and 12" apart inside panel.

5 Repeat **STEP 4** to secure RIGHT panel.



6 You have finished building your back wall.

 For squareness maintain 1-1/2" measurement along panel edge.

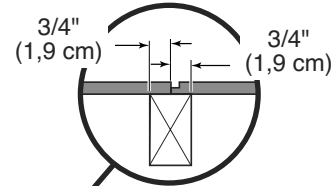

GABLE 12' x 12'

GABLE 12' x 16'

GABLE 12' x 20'

GABLE 12' x 24'

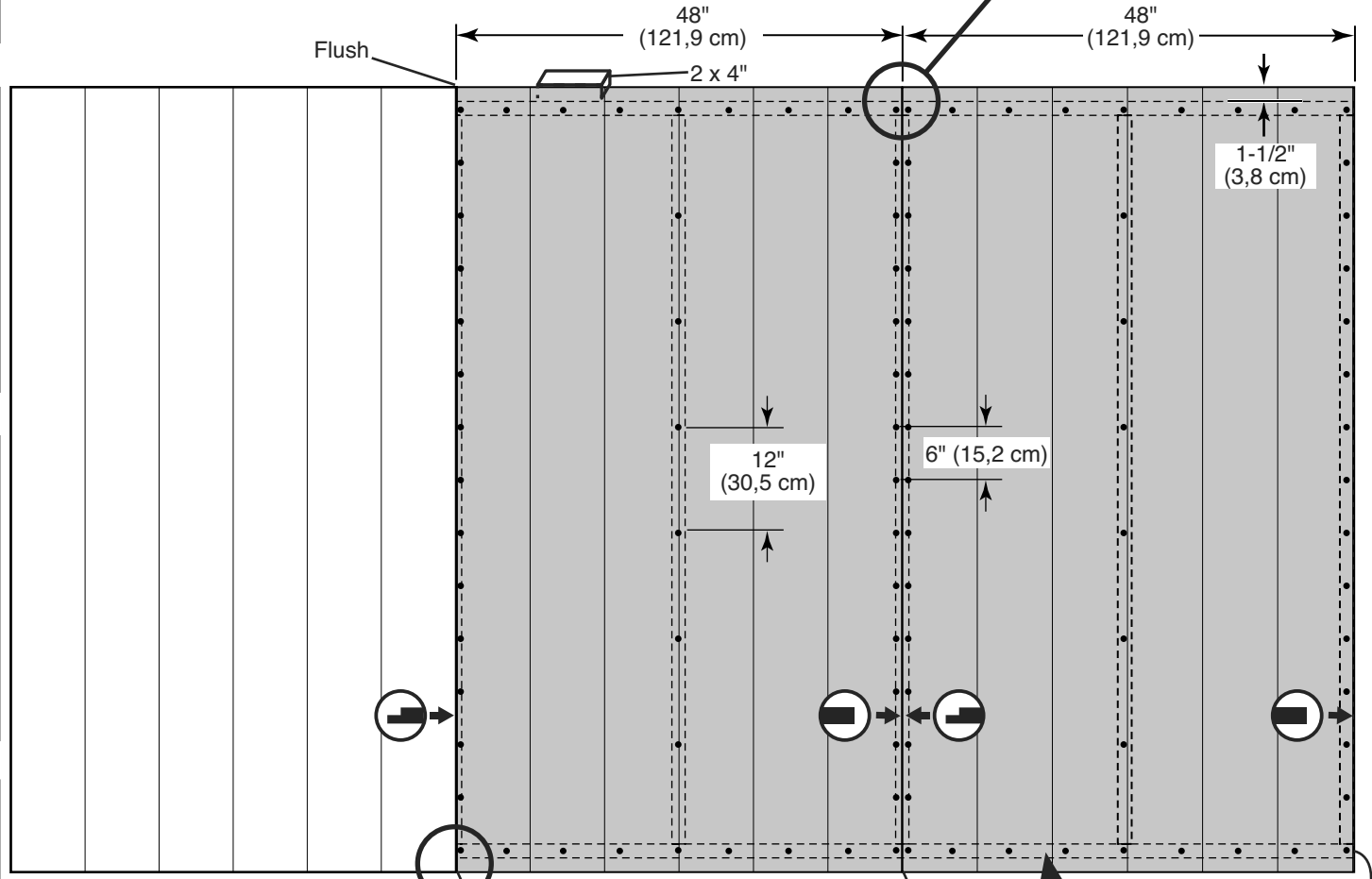

 To draw panels tight at seams angle nail.

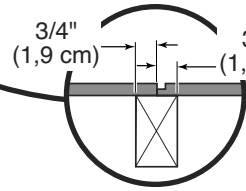
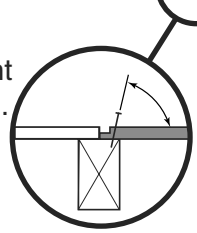

Primed side UP

Flush

12' x 12' SIDE WALL FRAMES

PARTS REQUIRED:

x4 **STL**
2 x 4 x 44-1/2" (5,1 x 10,2 x 113 cm)

x4 **TJ**
2 x 4 x 92-1/2" (5,1 x 10,2 x 235 cm)

x10 **AI**
2 x 4 x 78-1/2" (5,1 x 10,2 x 199,4 cm)

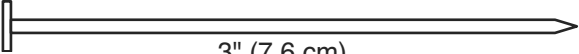
x48  3" (7,6 cm)

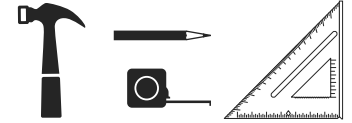

! YOU WILL BUILD TWO WALLS EXACTLY THE SAME.



- FOR 12' x 16', SKIP TO PAGE 24
- FOR 12' x 20', SKIP TO PAGE 27
- FOR 12' x 24', SKIP TO PAGE 30



BEGIN

- 1** Orient parts on edge on floor. Measure and mark from end of boards.
- 2** Use two 3" nails at each connection (**Fig. A**) and four 3" nails at seams (**Fig. B**).

FINISH

- 3** Repeat process to make second wall. Proceed to attach wall panels.

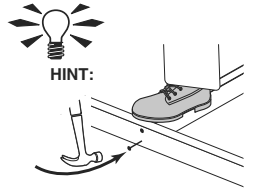

GABLE 12' x 12'

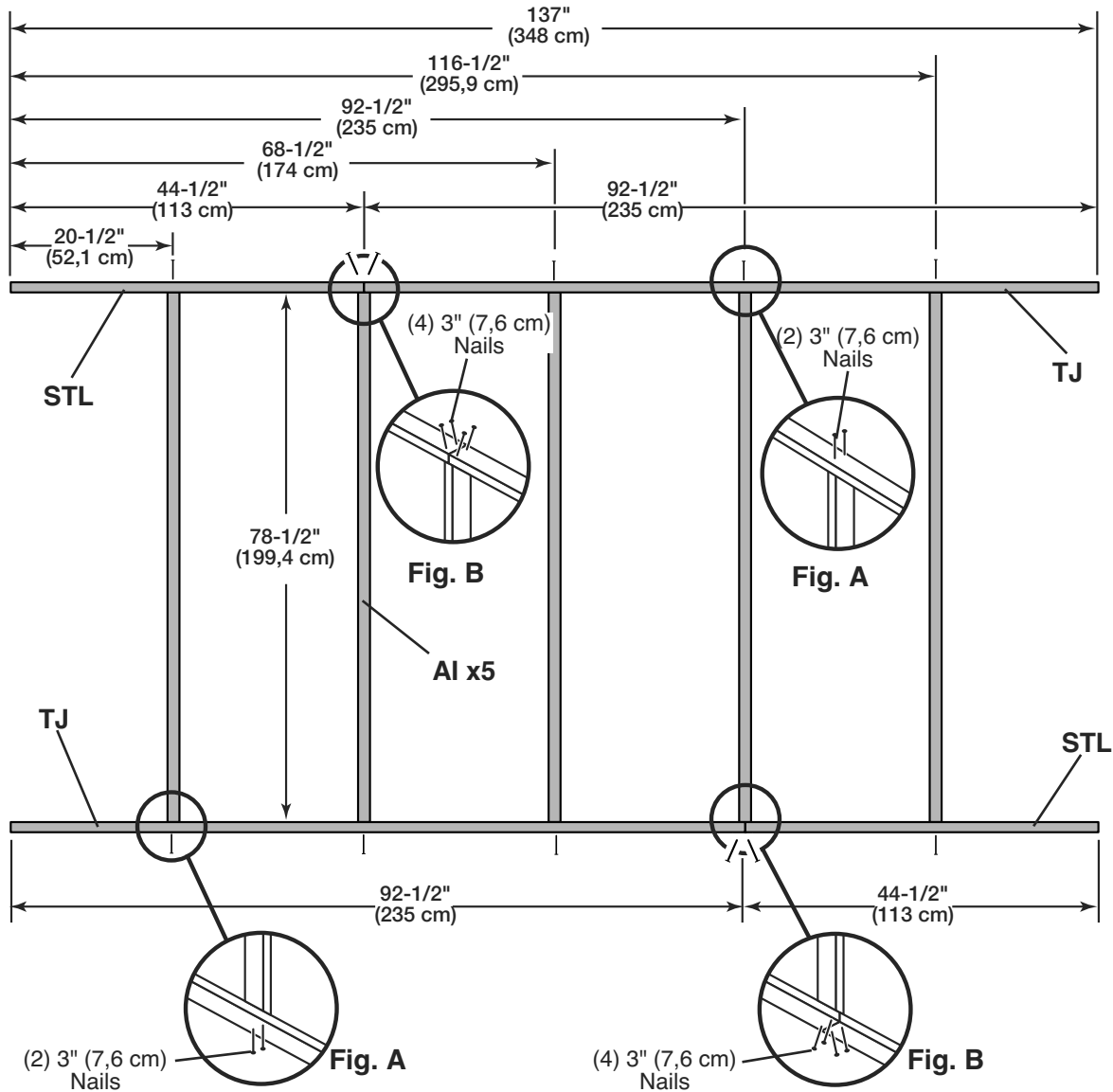

12' x 12' SIDE WALL PANELS

PARTS REQUIRED:

x2  3/8 x 48 x 84"
 (1 x 121,9 x 213,4 cm)

 **GAA**
 3/4" GAUGE
 BLOCK

 **UU**
 2 x 4 x 9"
 TEMP. SPACER

x70  2" (5,1 cm)

   

 Ensure your wall frame is square by installing one panel and squaring frame.

 **BEGIN**

1 Place a 48" x 84" panel onto wall frame with primed side up as shown.

Locate the panel 1-1/2" above the top plate. Use **UU** as a gauge block for the 1-1/2" top overhang measurement. Use **GAA** as a gauge block to mark the 3/4" side measurement on the wall stud. Secure panel with two 2" nails in the corners (**Fig. A**).

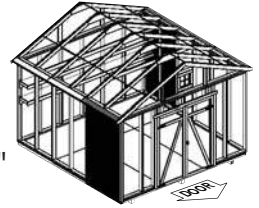

2 Move to the opposite end. Using the long edge of the panel as a lever, move the panel side-to-side until you have a 3/4" measurement on the wall stud. Secure corner with two 2" nails (**Fig. B**).

3 Nail the panel using 2" nails 6" apart on edges and 12" apart inside panel.

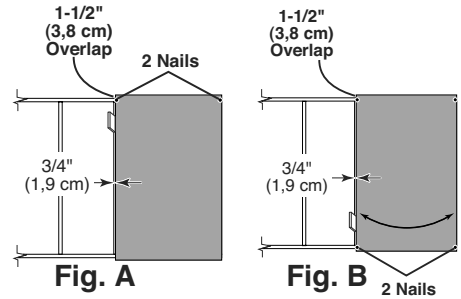

 For squareness maintain 3/4" and 1-1/2" measurement along panel edge.

GABLE 12' x 12'

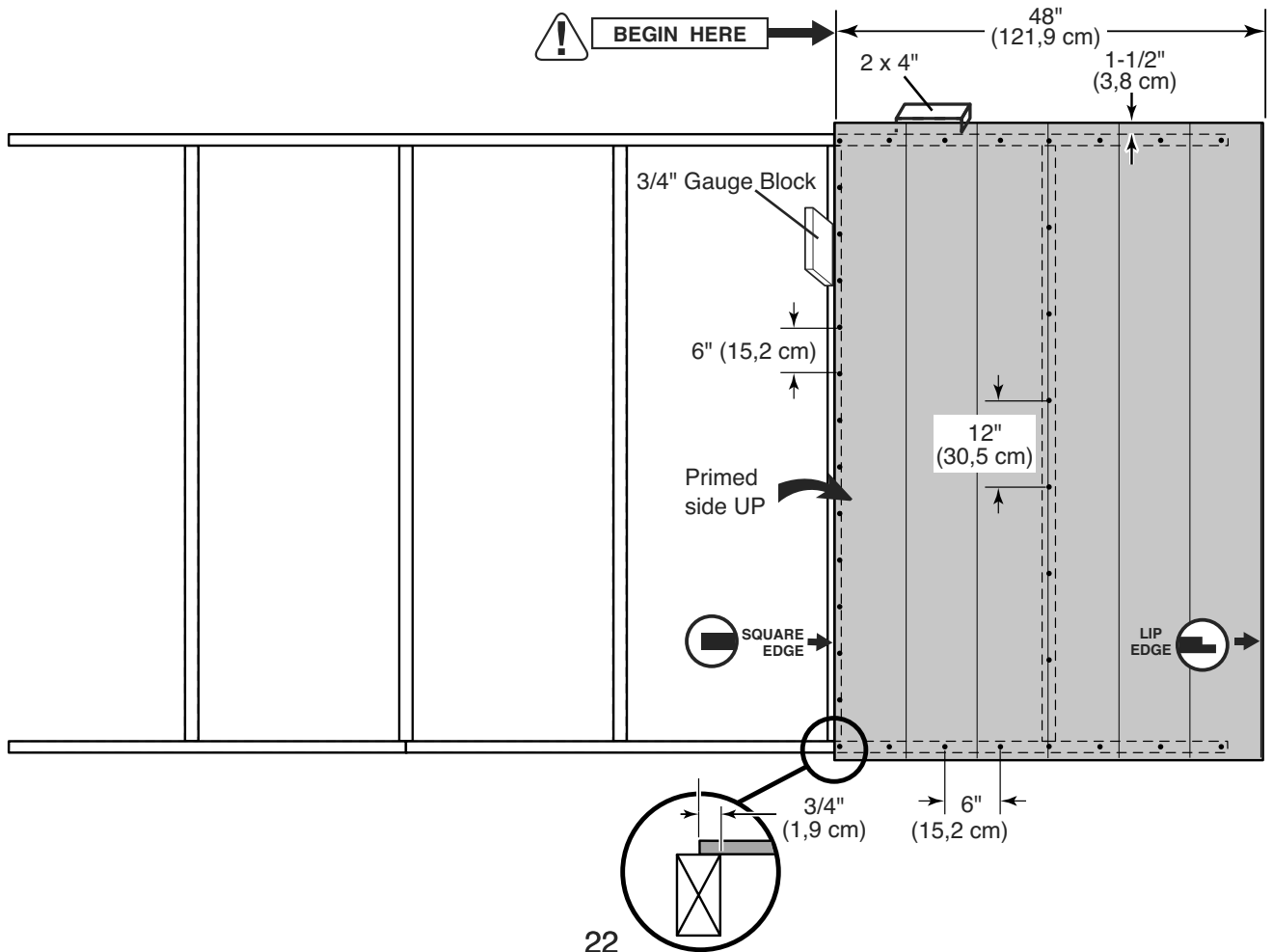

12' x 12' SIDE WALL PANELS

PARTS REQUIRED:

x4

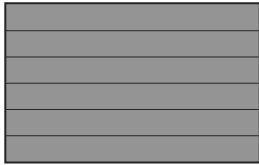

3/8 x 48 x 84"
(1 x 121,9 x 213,4 cm)

UU

2 x 4 x 9"
TEMP. SPACER

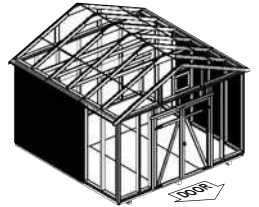
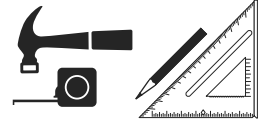
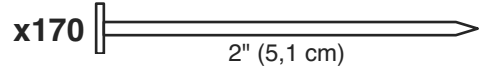

- 4 Place a 48" x 84" panel on frame as shown with primed side facing up flush with first panel. Nail using 2" nails 6" apart on edges and 12" apart inside panel.
- 5 Place next 48" x 84" panel on frame as shown with primed side facing up flush with second panel. Nail using 2" nails 6" apart on edges and 12" apart inside panel.
- 6 Carefully flip your sidewall over. Repeat **STEPS 1-5** to assemble your second side wall.



- 7 You have finished building both of your side walls. **Proceed to page 33.**

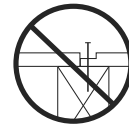

Do not nail in groove.

GABLE 12' x 12'

! For squareness maintain 1-1/2" measurement along panel edge.

To draw panels tight at seams angle nail.

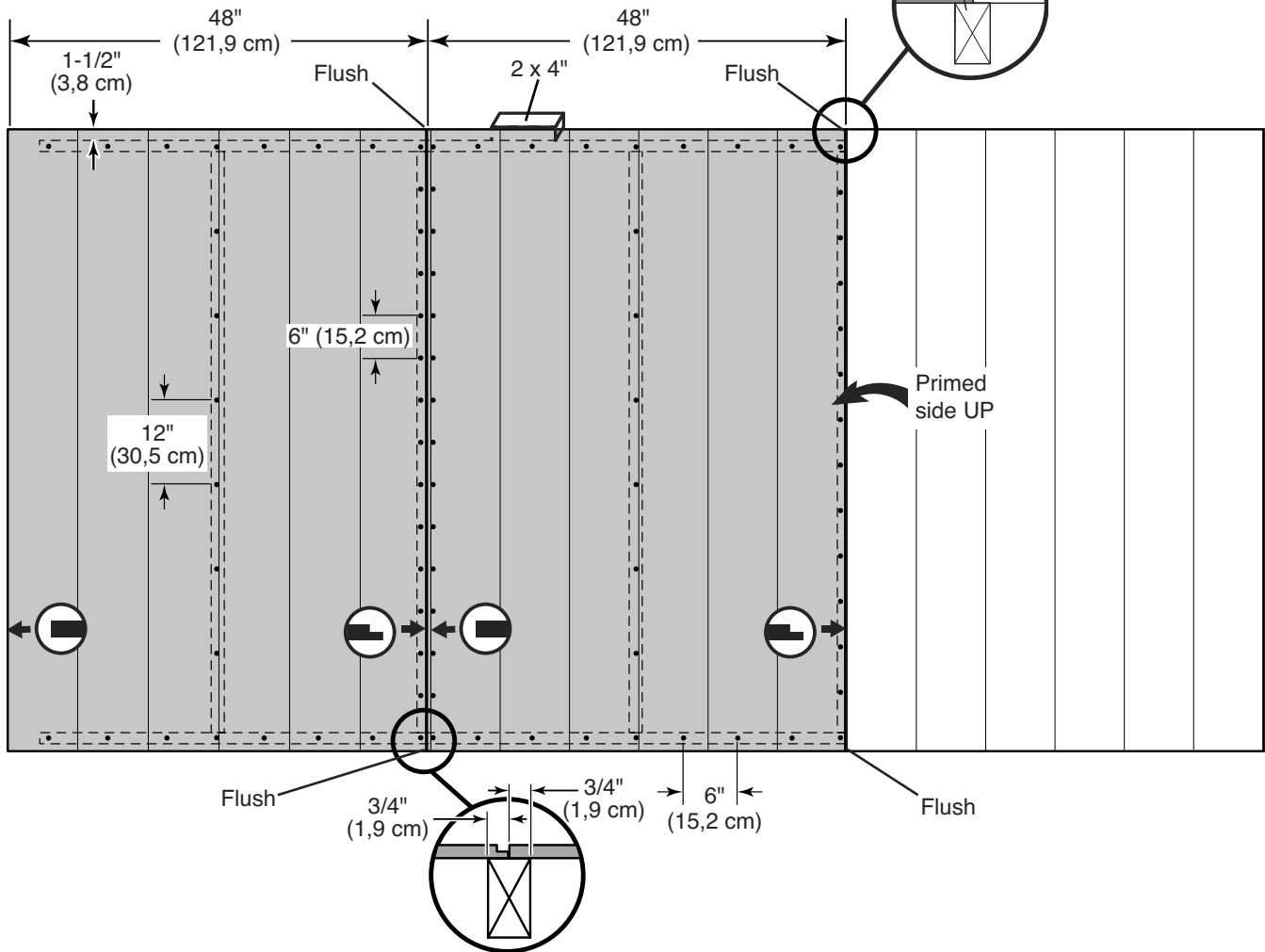

12' x 16' SIDE WALL FRAMES

PARTS REQUIRED:

x14 **AI**
2 x 4 x 78-1/2" (5,1 x 10,2 x 199,4 cm)

x8 **TJ**
2 x 4 x 92-1/2" (5,1 x 10,2 x 235 cm)

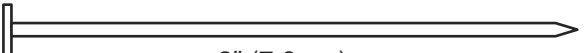
x64  3" (7,6 cm)

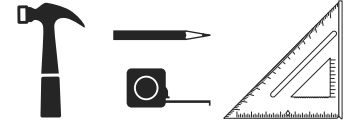

! YOU WILL BUILD TWO WALLS EXACTLY THE SAME.



• FOR 12' x 20', SKIP TO PAGE 27

• FOR 12' x 24', SKIP TO PAGE 30

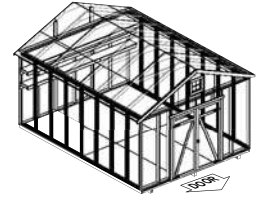

✓ BEGIN

1 Orient parts on edge on floor. Measure and mark from end of boards.

2 Use two 3" nails at each connection (**Fig. A**) and four 3" nails at seams (**Fig. B**).



HINT:

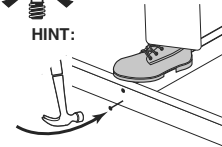

FINISH

3 Repeat process to make second wall frame. Proceed to attach wall panels.

GABLE 12' x 16'

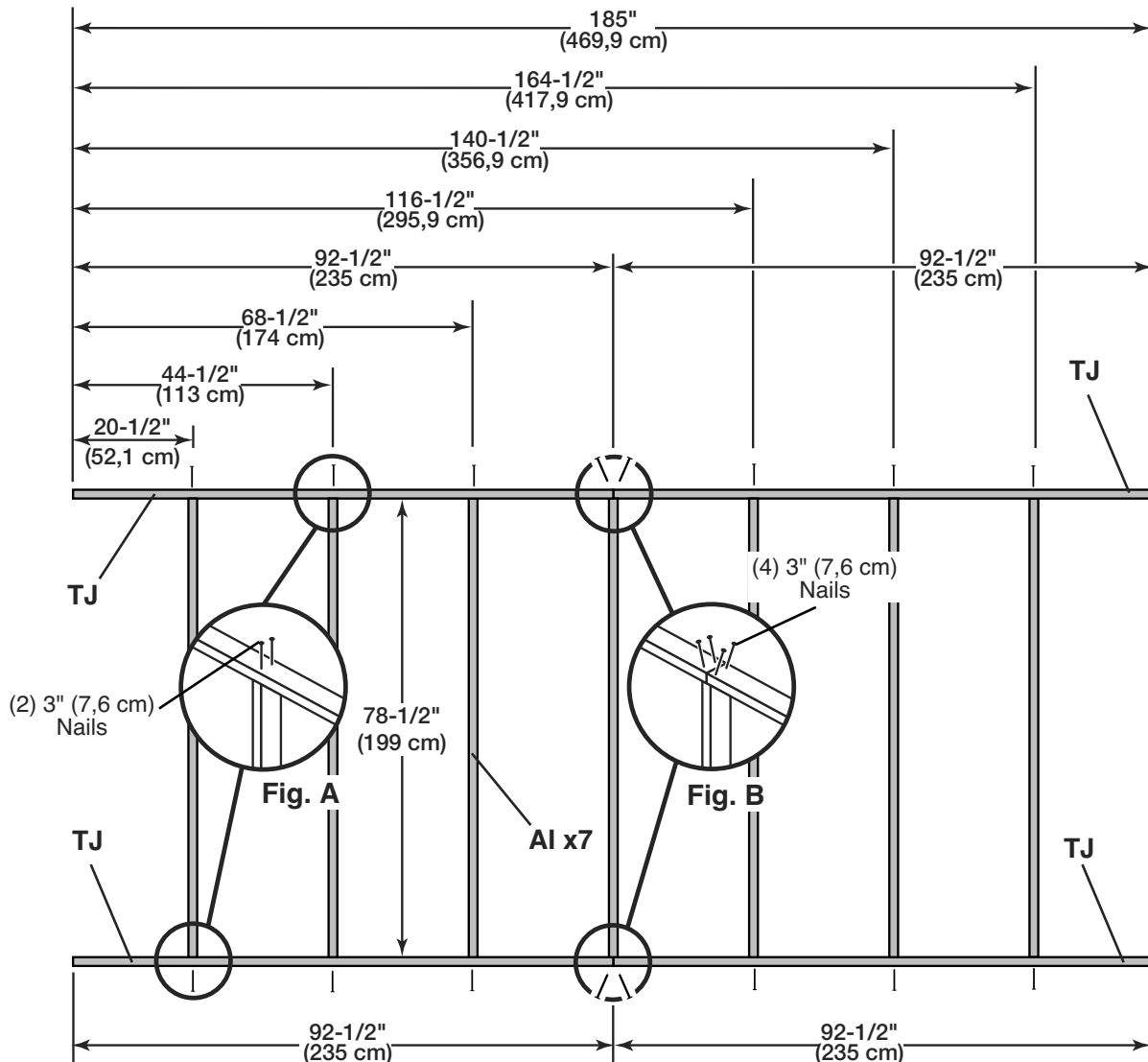

12' x 16' SIDE WALL PANELS

PARTS REQUIRED:

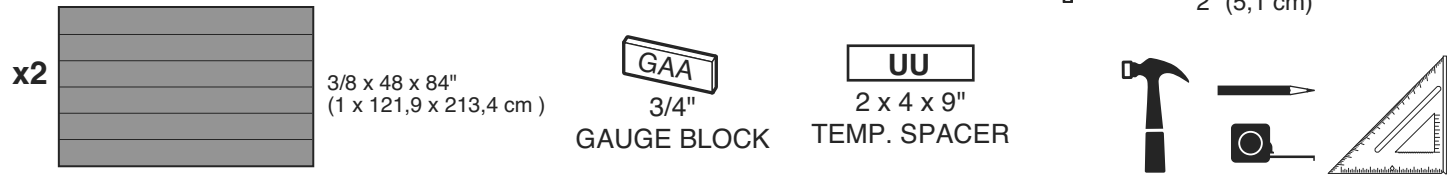

! Ensure your wall frame is square by installing one panel and squaring frame.

✓ BEGIN

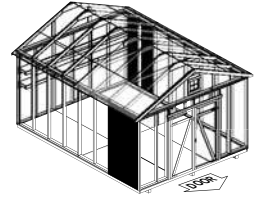

1 Place a 48" x 84" panel onto wall frame with primed side up as shown.

Locate the panel 1-1/2" above the top plate. Use **UU** as a gauge block for the 1-1/2" top overhang measurement. Use **GAA** as a gauge block to mark the 3/4" side measurement on the wall stud. Secure panel with two 2" nails in the corners (**Fig. A**).

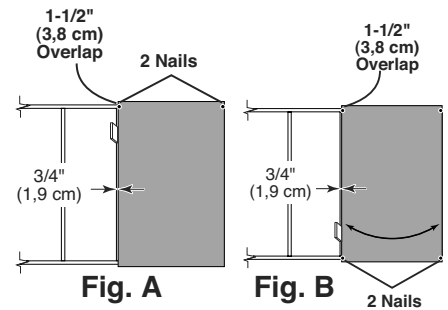

2 Move to the opposite end. Using the long edge of the panel as a lever, move the panel side-to-side until you have a 3/4" measurement on the wall stud. Secure corner with two 2" nails (**Fig. B**).

3 Nail the panel using 2" nails 6" apart on edges and 12" apart inside panel.

! For squareness maintain 3/4" and 1-1/2" measurement along panel edge.

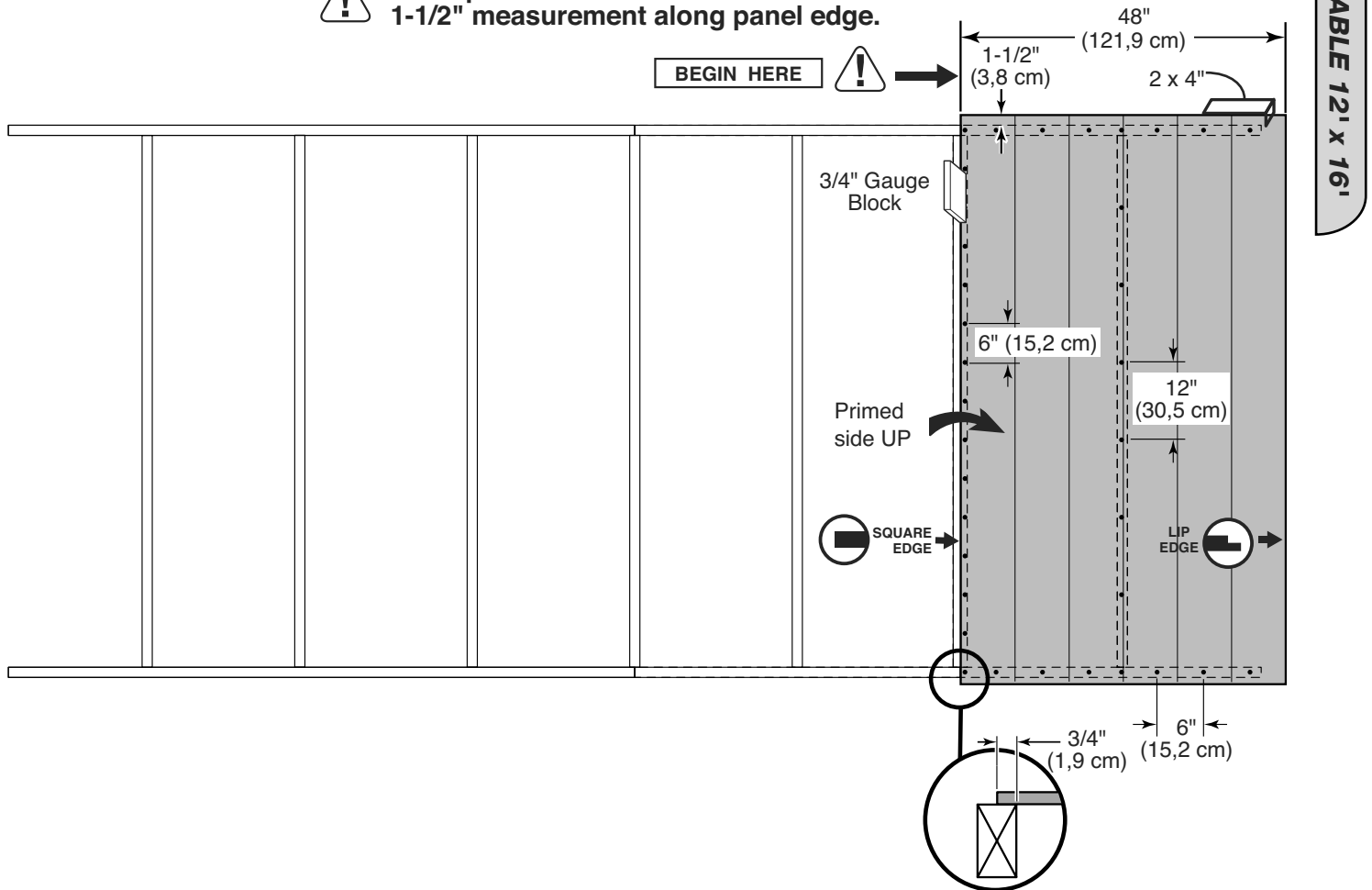

12' x 16' SIDE WALL PANELS

PARTS REQUIRED:

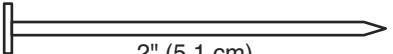
x270  2" (5,1 cm)

x6

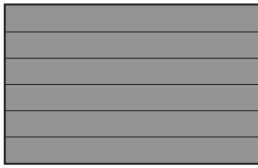

3/8 x 48 x 84"
(1 x 121,9 x 213,4 cm)

UU

2 x 4 x 9"
TEMP. SPACER

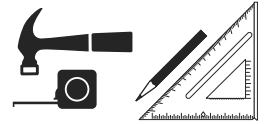

4 Place 48" x 84" panel on frame as shown with primed side facing up flush with first panel. Nail using 2" nails 6" apart on edges and 12" apart inside panel.

5 Repeat **STEP 4** for remaining panels.

6 Carefully flip your sidewall over. Repeat **STEPS 1-5** to assemble your second side wall.

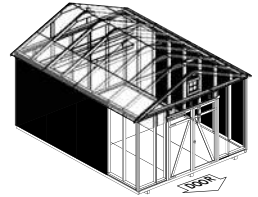

FINISH

7 You have finished building both of your side walls. **Proceed to page 33.**

! For squareness maintain 1-1/2" measurement along panel edge.

💡 To draw panels tight at seams angle nail.

GABLE 12' x 16'

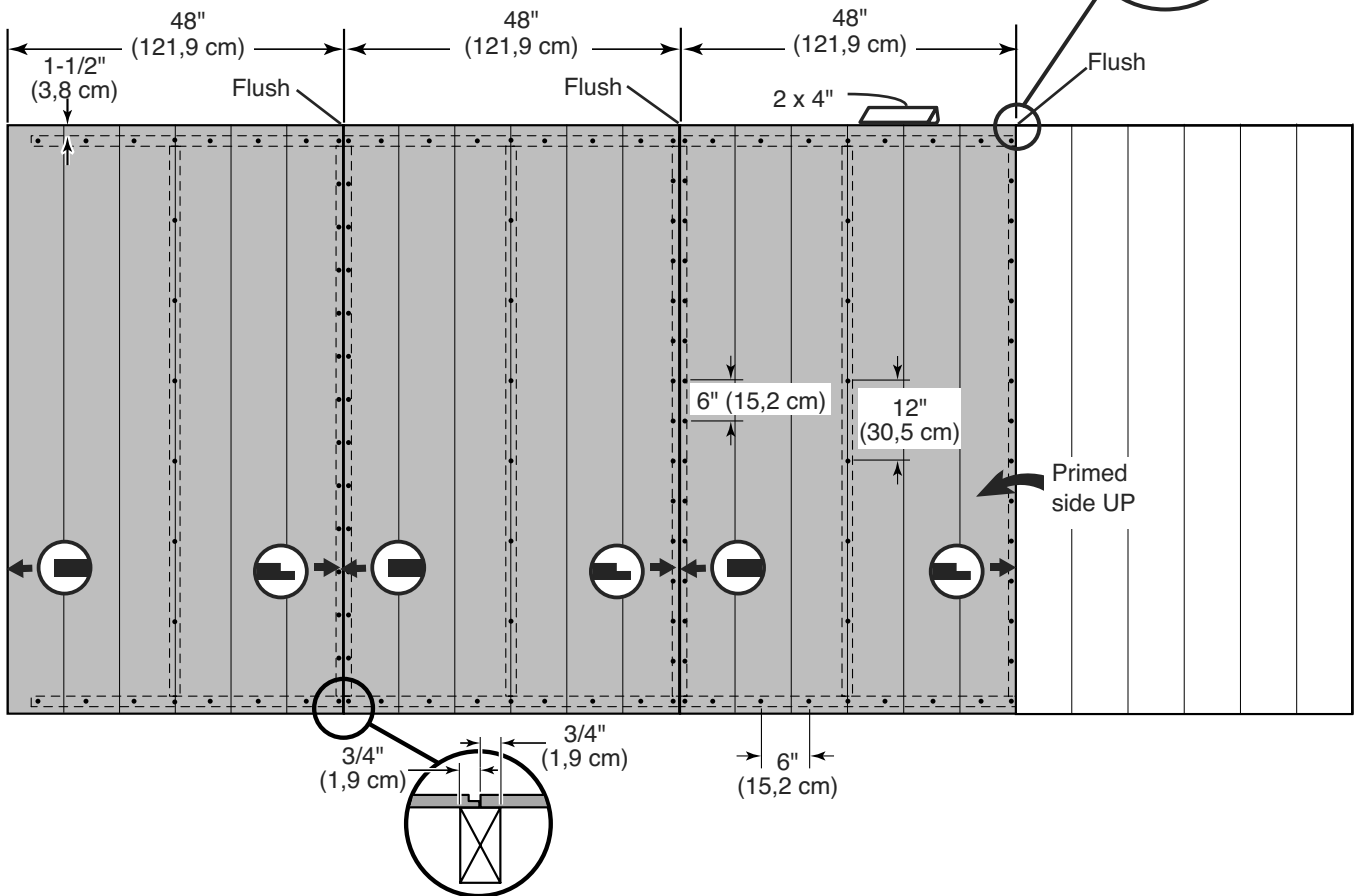

12' x 20' SIDE WALL FRAMES

PARTS REQUIRED:

- x4 **TJ**
2 x 4 x 92-1/2" (5,1 x 10,2 x 235 cm)
- x4 **TP**
2 x 4 x 96" (5,1 x 10,2 x 243,9 cm)
- x4 **STL**
2 x 4 x 44-1/2" (5,1 x 10,2 x 113 cm)
- x18 **AI**
2 x 4 x 78-1/2" (5,1 x 10,2 x 199,4 cm)

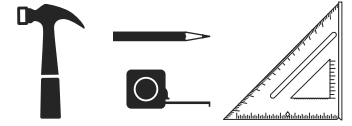
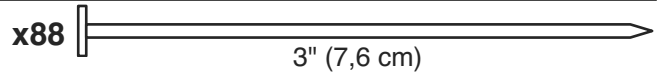

! YOU WILL BUILD TWO WALLS EXACTLY THE SAME.



• FOR 12' x 24', SKIP TO PAGE 30

✓ BEGIN

- 1 Orient parts on edge on floor. Measure and mark from end of boards.
- 2 Use two 3" nails at each connection (**Fig. A**) and four 3" nails at seams (**Fig. B**).

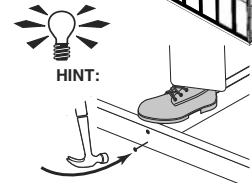
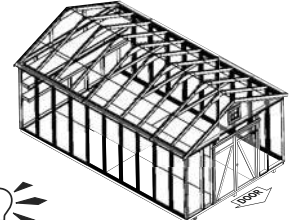

FINISH

- 3 Repeat process to make second wall frame. Proceed to attach wall panels.

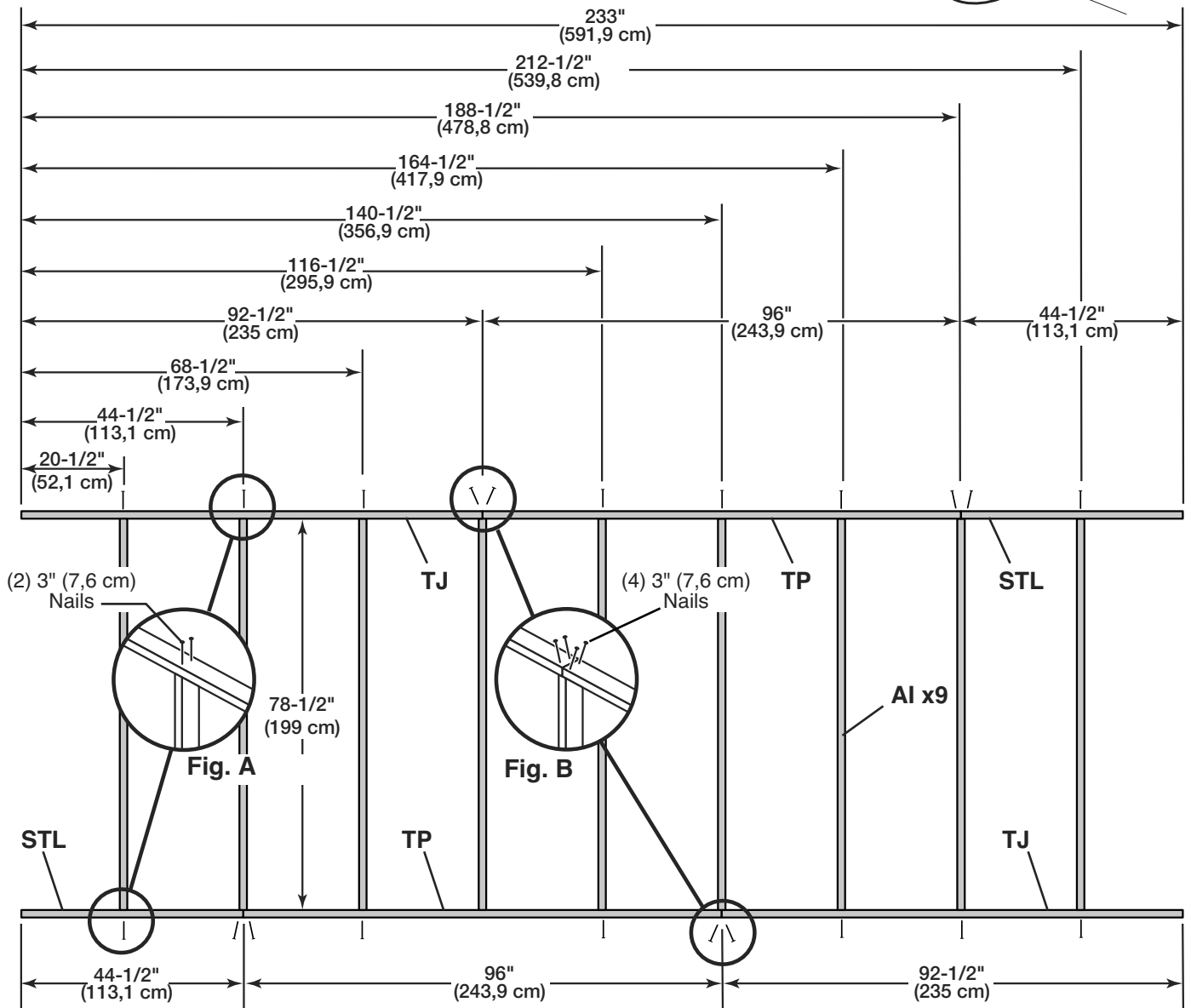



GABLE 12' x 20'

12' x 20' SIDE WALL PANELS



PARTS REQUIRED:

x2  3/8 x 48 x 84"
 (1 x 121,9 x 213,4 cm)

GAA  3/4"
 GAUGE BLOCK

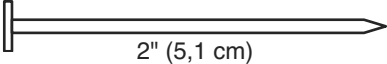
UU  2 x 4 x 9"
 TEMP. SPACER

x70  2" (5,1 cm)

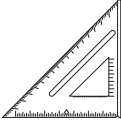
 Ensure your wall frame is square by installing one panel and squaring frame.

✓ BEGIN

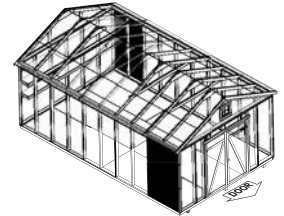

- 1 Place a 48" x 84" panel onto wall frame with primed side up as shown.

Locate the panel 1-1/2" above the top plate. Use a **UU** as a gauge block for the 1-1/2" top overhang measurement. Use **GAA** as a gauge block to mark the 3/4" side measurement on the wall stud. Secure panel with two 2" nails in the corners (**Fig. A**).

- 2 Move to the opposite end. Using the long edge of the panel as a lever, move the panel side-to-side until you have a 3/4" measurement on the wall stud. Secure corner with two 2" nails (**Fig. B**).

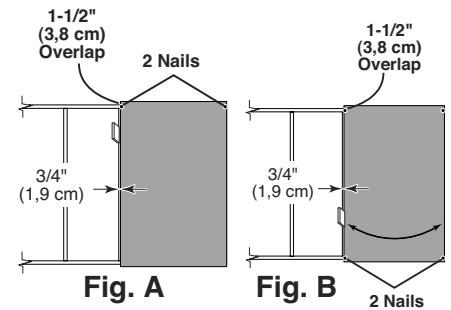

- 3 Nail the panel using 2" nails 6" apart on edges and 12" apart inside panel.

 For squareness maintain 3/4" and 1-1/2" measurement along panel edge.

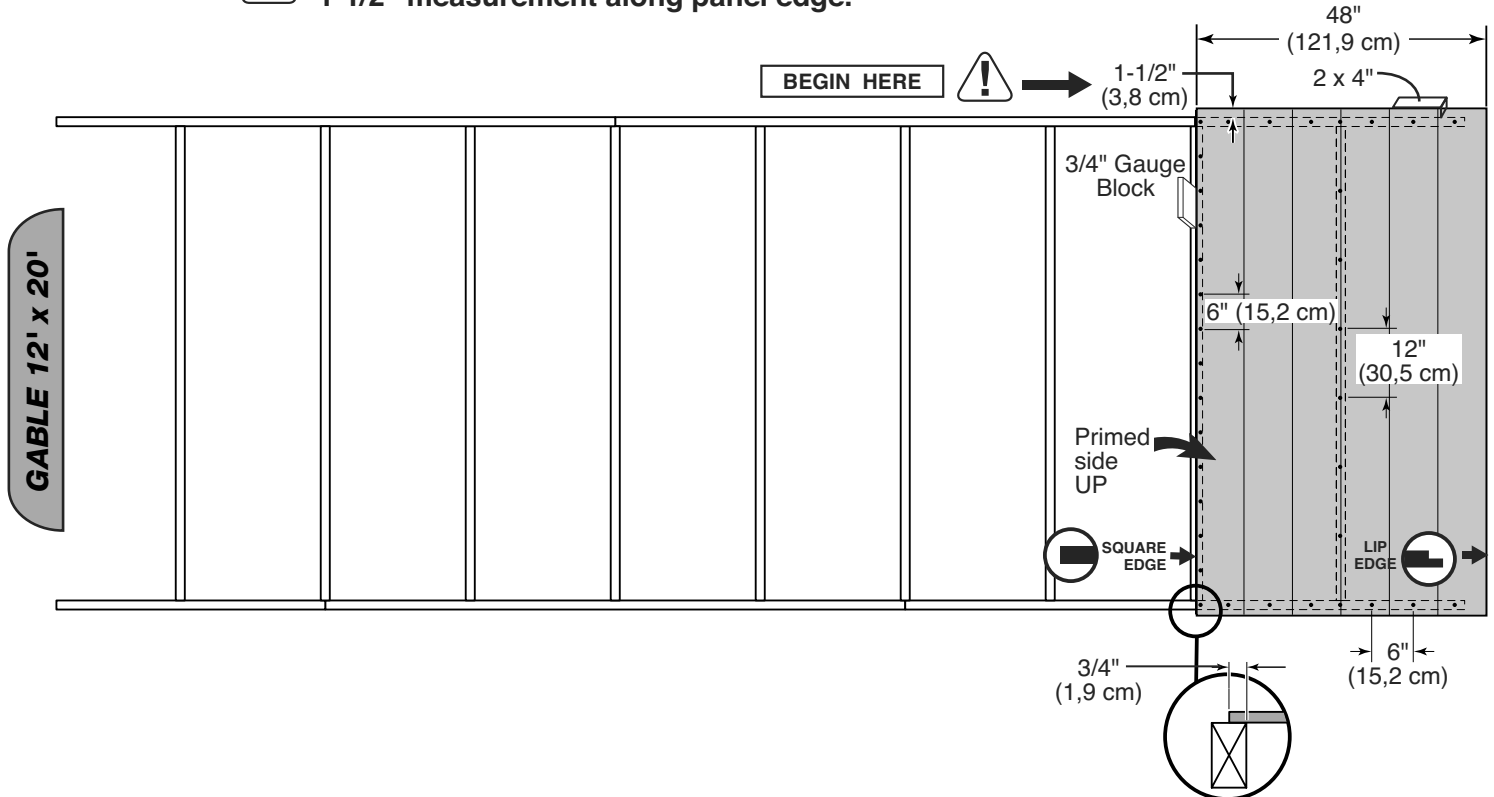

12' x 20' SIDE WALL PANELS

PARTS REQUIRED:

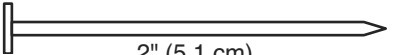
x370  2" (5,1 cm)

x8

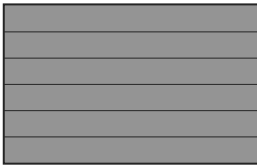

3/8 x 48 x 84"
(1 x 121,9 x 213,4 cm)

UU
2 x 4 x 9"
TEMP. SPACER

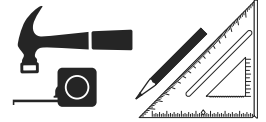

4 Place 48" x 84" panel on frame as shown with primed side facing up flush with first panel. Nail using 2" nails 6" apart on edges and 12" apart inside panel.

5 Repeat **STEP 4** for remaining panels.

6 Carefully flip your sidewall over. Repeat **STEPS 1-5** to assemble your second side wall.

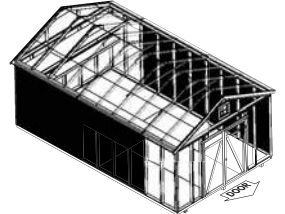

FINISH

7 You have finished building both of your side walls. **Proceed to page 33.**

 **For squareness maintain 1-1/2" measurement along panel edge.**

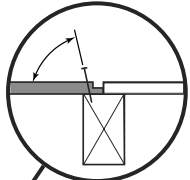
 To draw panels tight at seams angle nail. 

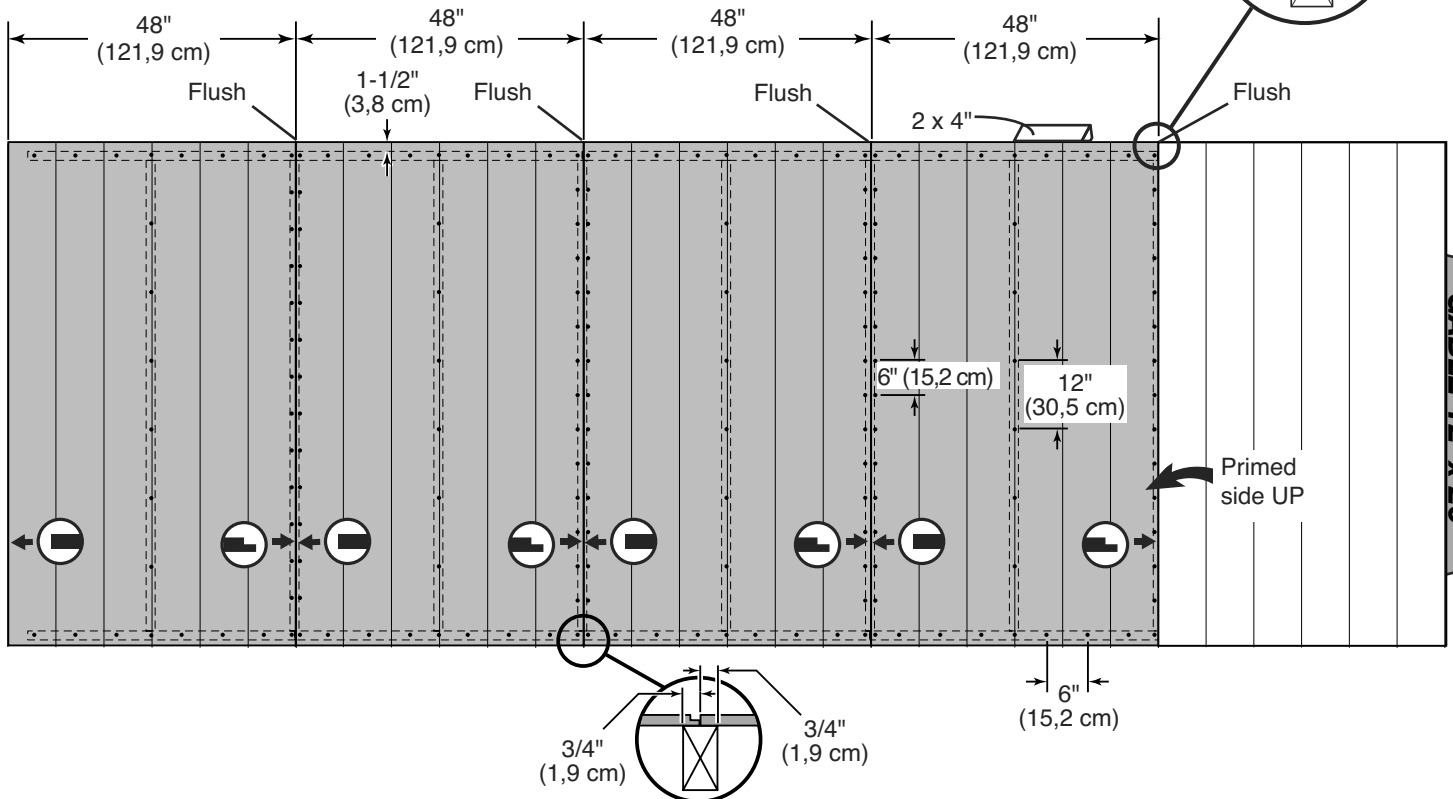

12' x 24' SIDE WALL FRAMES

PARTS REQUIRED:

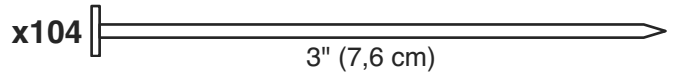

x4 **TP**
2 x 4 x 96" (5,1 x 10,2 x 243,9 cm)

x8 **TJ**
2 x 4 x 92-1/2" (5,1 x 10,2 x 235 cm)

x22 **AI**
2 x 4 x 78-1/2" (5,1 x 10,2 x 199,4 cm)

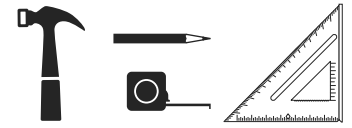

BEGIN **YOU WILL BUILD TWO WALLS EXACTLY THE SAME.**

1 Orient parts on edge on floor. Measure and mark from end of boards.

2 Use two 3" nails at each connection (**Fig. A**) and four 3" nails at seams (**Fig. B**).

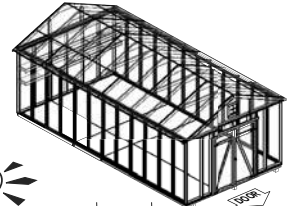

FINISH

3 Repeat process to make second wall frame. Proceed to attach wall panels.

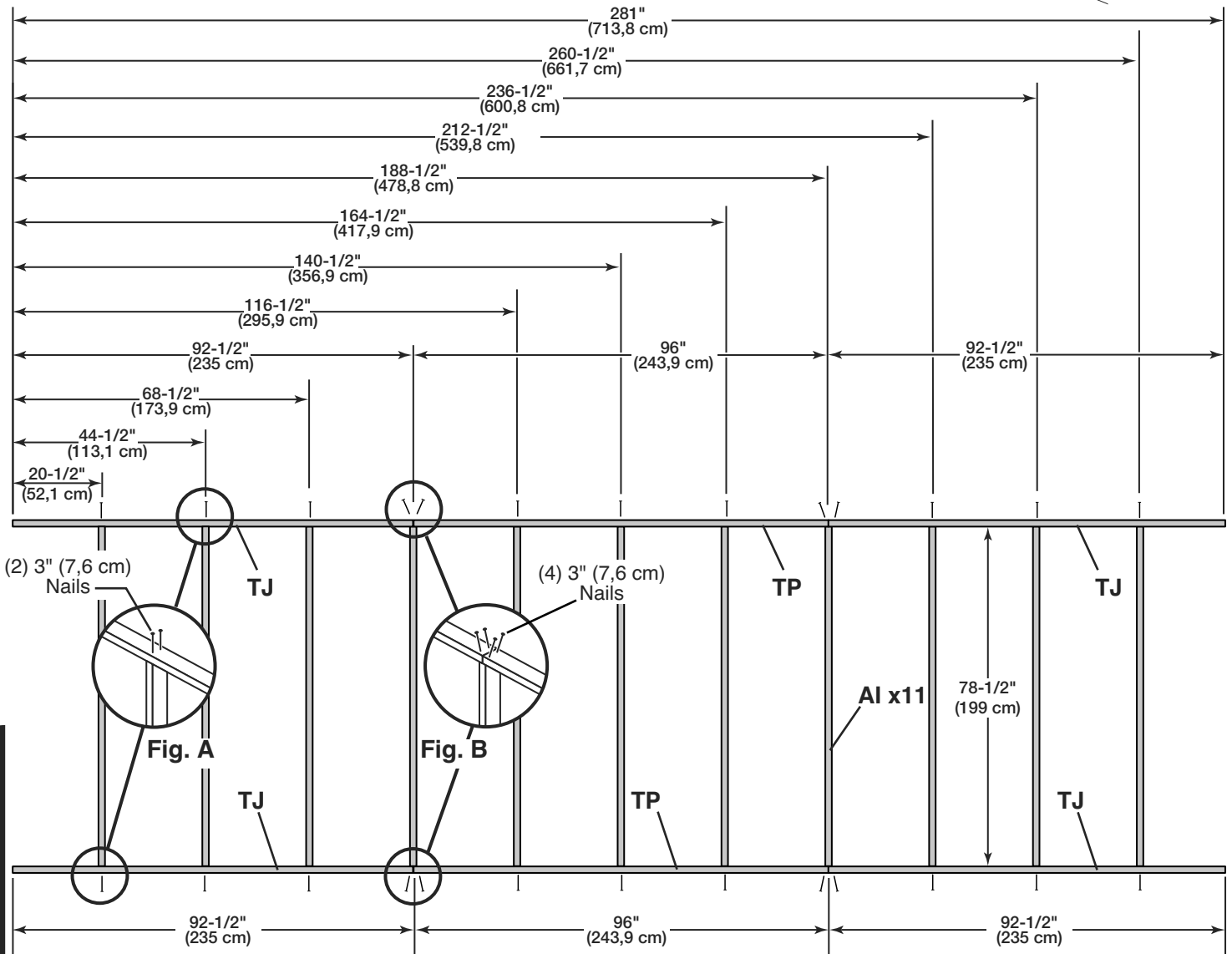
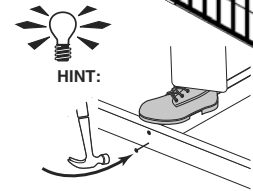

GABLE 12' x 24'

12' x 24' SIDE WALL PANELS

PARTS REQUIRED:

x2  3/8 x 48 x 84"
 (1 x 121,9 x 213,4 cm)

GAA
 3/4"
 GAUGE BLOCK

UU
 2 x 4 x 9"
 TEMP. SPACER

x70  2" (5,1 cm)



 Ensure your wall frame is square by installing one panel and squaring frame.

✓ BEGIN

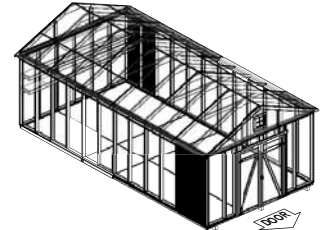

1 Place a 48" x 84" panel onto wall frame with primed side up as shown.

Locate the panel 1-1/2" above the top plate. Use **UU** as a gauge block for the 1-1/2" top overhang measurement. Use **GAA** as a gauge block to mark the 3/4" side measurement on the wall stud. Secure panel with two 2" nails in the corners (**Fig. A**).

2 Move to the opposite end. Using the long edge of the panel as a lever, move the panel side-to-side until you have a 3/4" measurement on the wall stud. Secure corner with two 2" nails (**Fig. B**).

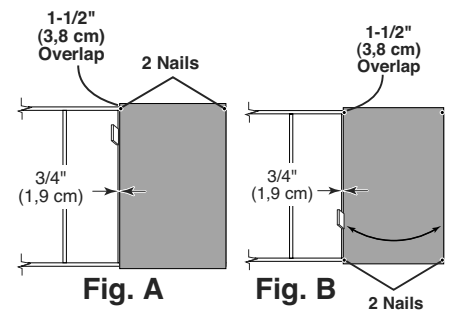

3 Nail the panel using 2" nails 6" apart on edges and 12" apart inside panel.

 For squareness maintain 3/4" and 1-1/2" measurement along panel edge.

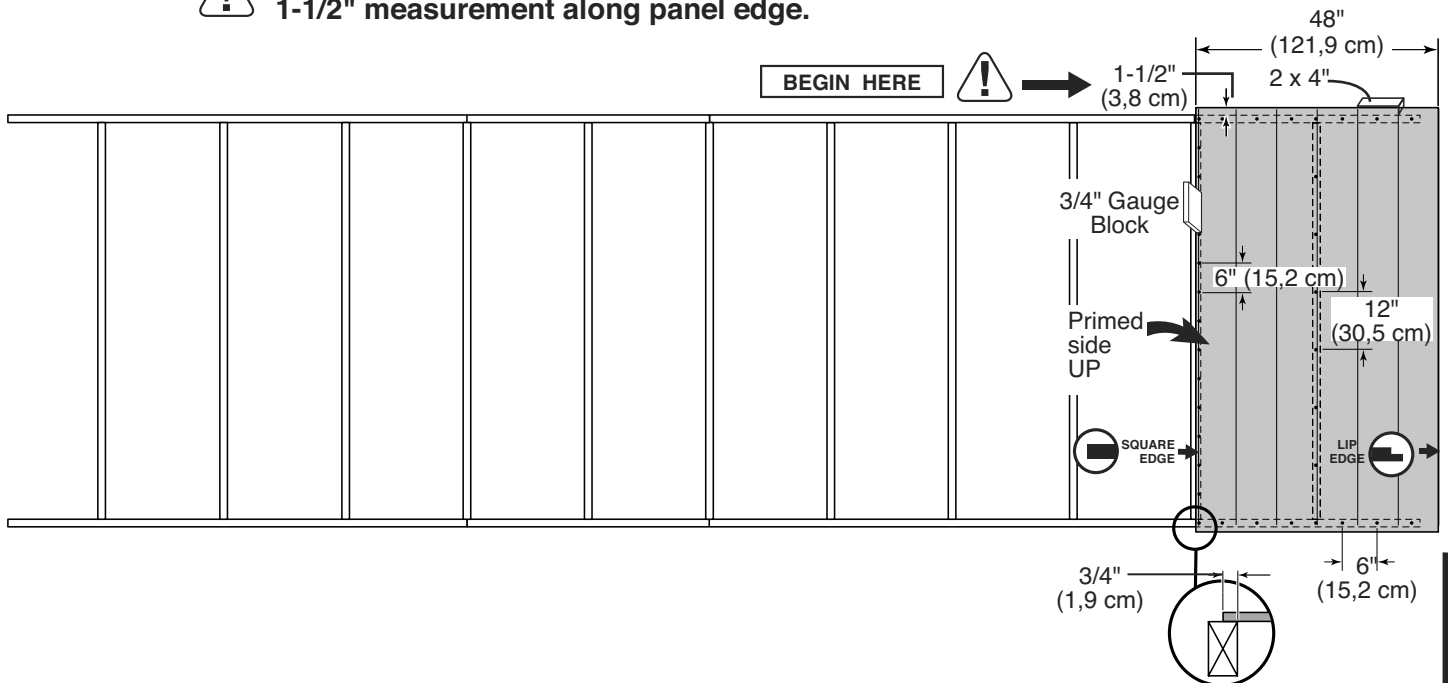

GABLE 12' x 24'

12' x 24' SIDE WALL PANELS

PARTS REQUIRED:

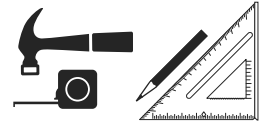
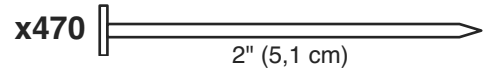
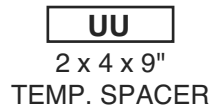
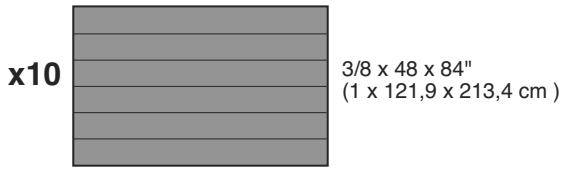

4 Place 48" x 84" panel on frame as shown with primed side facing up flush with first panel. Nail using 2" nails 6" apart on edges and 12" apart inside panel.

5 Repeat **STEP 4** for remaining panels.

6 Carefully flip your sidewall over. Repeat **STEPS 1-5** to assemble your second side wall.



7 You have finished building both of your side walls. Proceed to page 33.

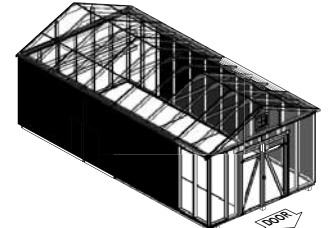

⚠ For squareness maintain 1-1/2" measurement along panel edge.

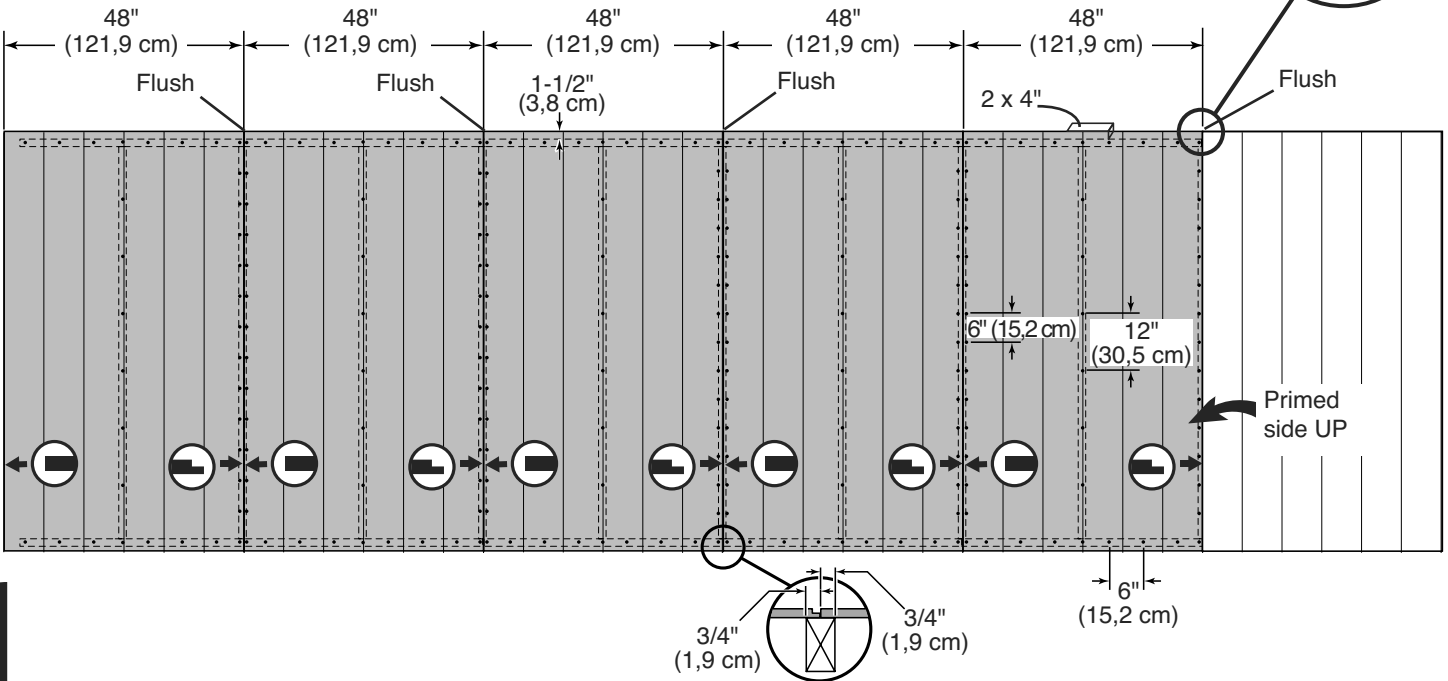
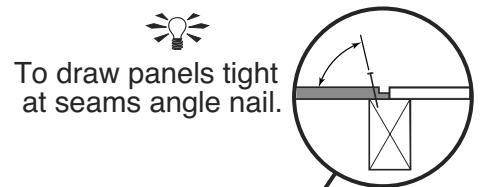

GABLE 12' x 24'

FRONT WALL FRAME (Door Header)

PARTS REQUIRED:

x5 **UU**
2 x 4 x 9" (5,1 x 10,2 x 22,9 cm)

x1 **AM**
2 x 4 x 67" (5,1 x 10,2 x 170,2 cm)

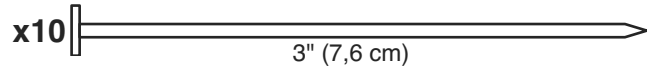

✓ BEGIN

- 1 Orient parts on edge on floor as shown.
- 2 Nail using two 3" nails at each connection.

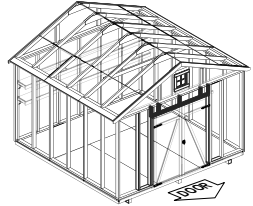

FINISH

- 3 Proceed to assembling front wall frame.

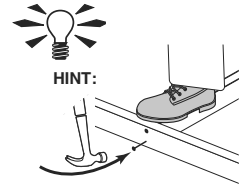

GABLE 12' x 12'

GABLE 12' x 16'

GABLE 12' x 20'

GABLE 12' x 24'

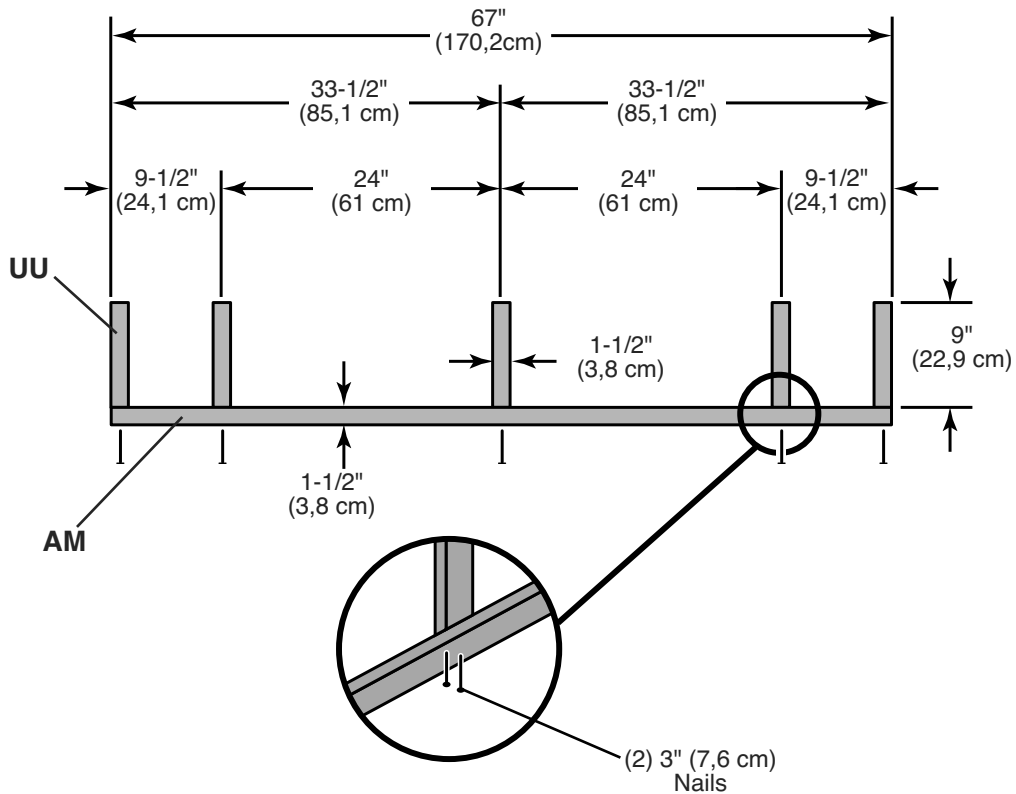

FRONT WALL FRAME

PARTS REQUIRED:

x2 **SKA**
2 x 4 x 40" (5,1 x 10,2 x 101,6 cm)

x1 **SP**
2 x 4 x 48" (5,1 x 10,2 x 121,9 cm)

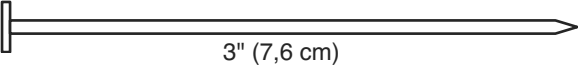
x24  3" (7,6 cm)

x6 **AI**
2 x 4 x 78-1/2" (5,1 x 10,2 x 199,4 cm)

x1 **TP**
2 x 4 x 96" (5,1 x 10,2 x 244,9 cm)



BEGIN

1 Orient parts on edge on floor around ladder as shown.

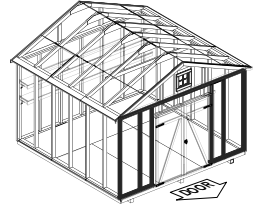

2 Use two 3" nails at each connection (**Fig. A**).

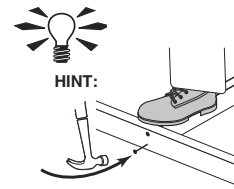

DIMENSIONS ARE TO CENTER OF STUDS.

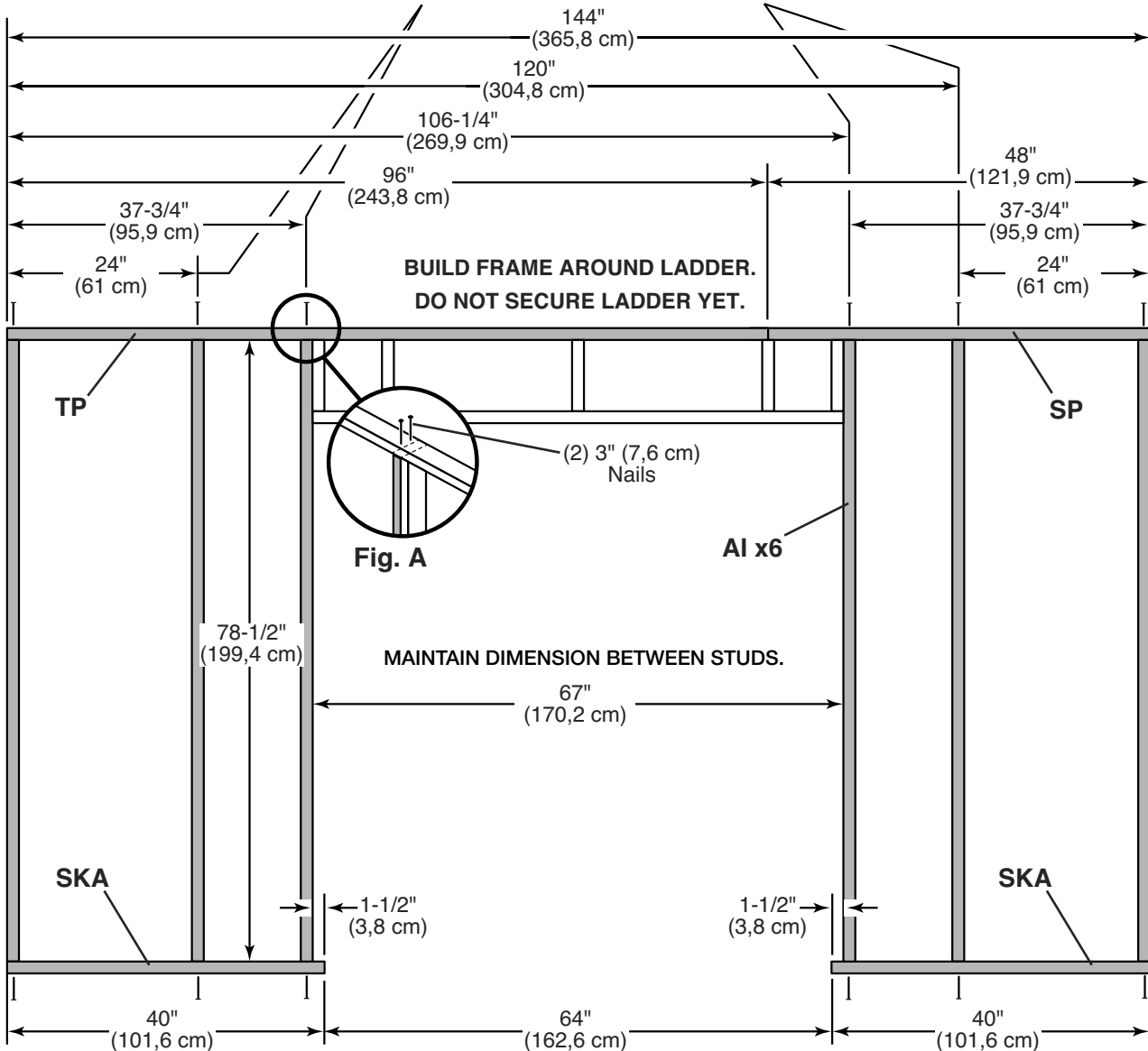

GABLE 12' x 12'

GABLE 12' x 16'

GABLE 12' x 20'

GABLE 12' x 24'

FRONT WALL FRAME

PARTS REQUIRED:

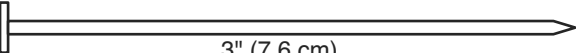
x28  3" (7,6 cm)



- Secure ladder to frame with 3" nails as shown. Use two 3" nails at each connection (**Fig. A**) and four 3" nails at seams (**Fig. B**).

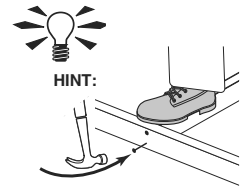
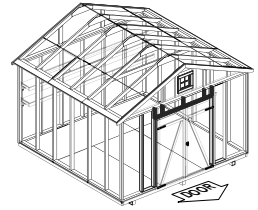

DIMENSIONS ARE TO CENTER OF STUDS.

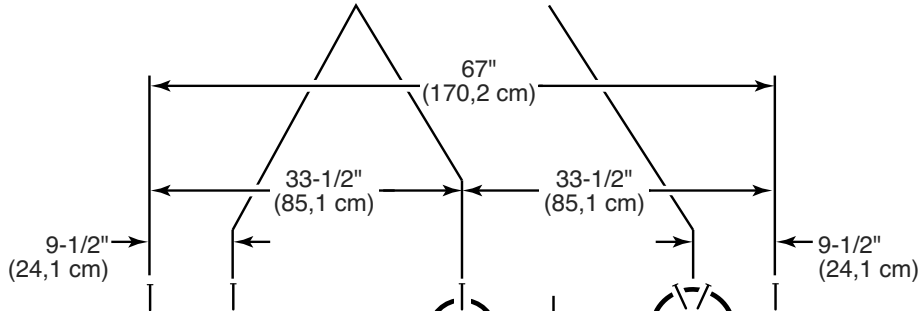

(2) 3" (7,6 cm) Nails

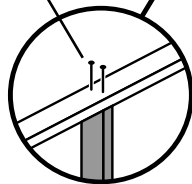

Fig. A

(4) 3" (7,6 cm) Nails

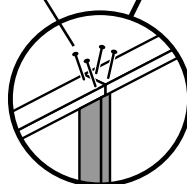

Fig. B

MAINTAIN DIMENSION BETWEEN STUDS.

67" (170,2 cm)

GABLE 12' x 12'

GABLE 12' x 16'

GABLE 12' x 20'

GABLE 12' x 24'

FRONT WALL FRAME

PARTS REQUIRED:

x2 **UM**
2 x 4 x 68" (5,1 x 10,2 x 172,7 cm)

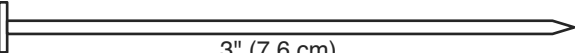
x24  3" (7,6 cm)



4 Orient parts on edge on floor as shown.

5 Secure using 3" nails as shown.

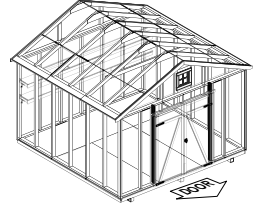

GABLE 12' x 12'



6 You have finished your front wall frame.



HINT:

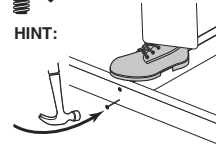

GABLE 12' x 16'

GABLE 12' x 20'

GABLE 12' x 24'

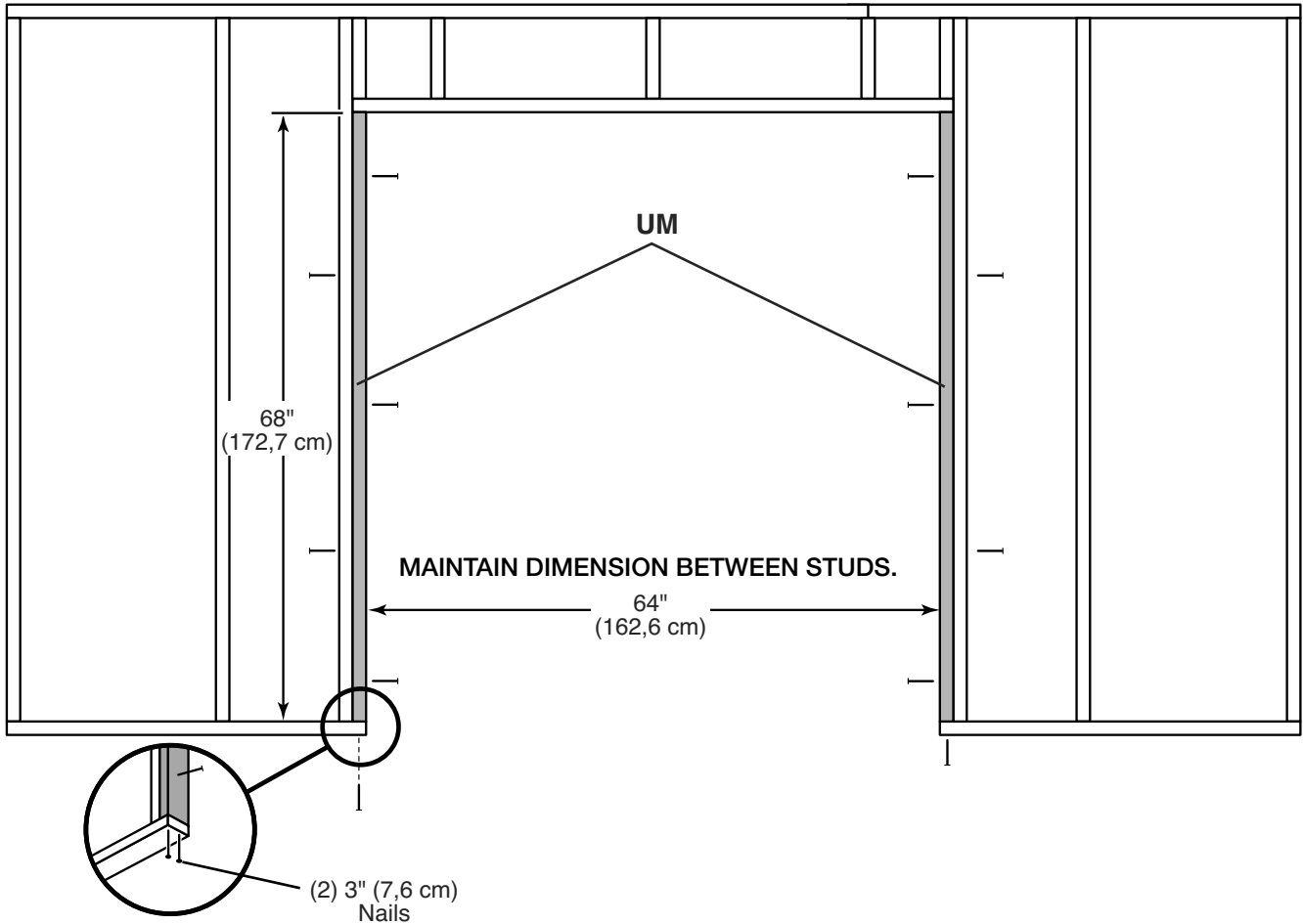

FRONT WALL PANELS

PARTS REQUIRED:

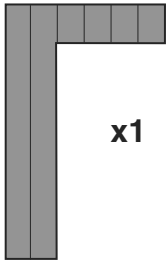

x1



3/4" GAUGE
BLOCK



2 x 4 x 9"
TEMP. SPACER

x51

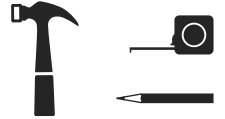
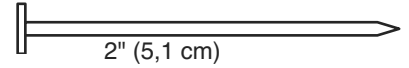

✓ BEGIN

- 1 Place the LEFT panel onto wall frame as shown with primed side up.
- 2 Use **GAA** as a gauge block to mark the 3/4" measurement on the wall stud. Locate the panel 1-1/2" from the top plate.
- 3 Nail panels to frame with two 2" nails 6" apart on edges.

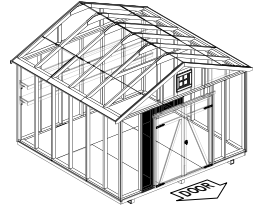

GABLE 12' x 12'



FINISH

- 4 Proceed to attaching your other front panel.

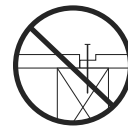

Do not nail
in groove.

! For squareness maintain 3/4" and 1-1/2" measurement along panel edge.

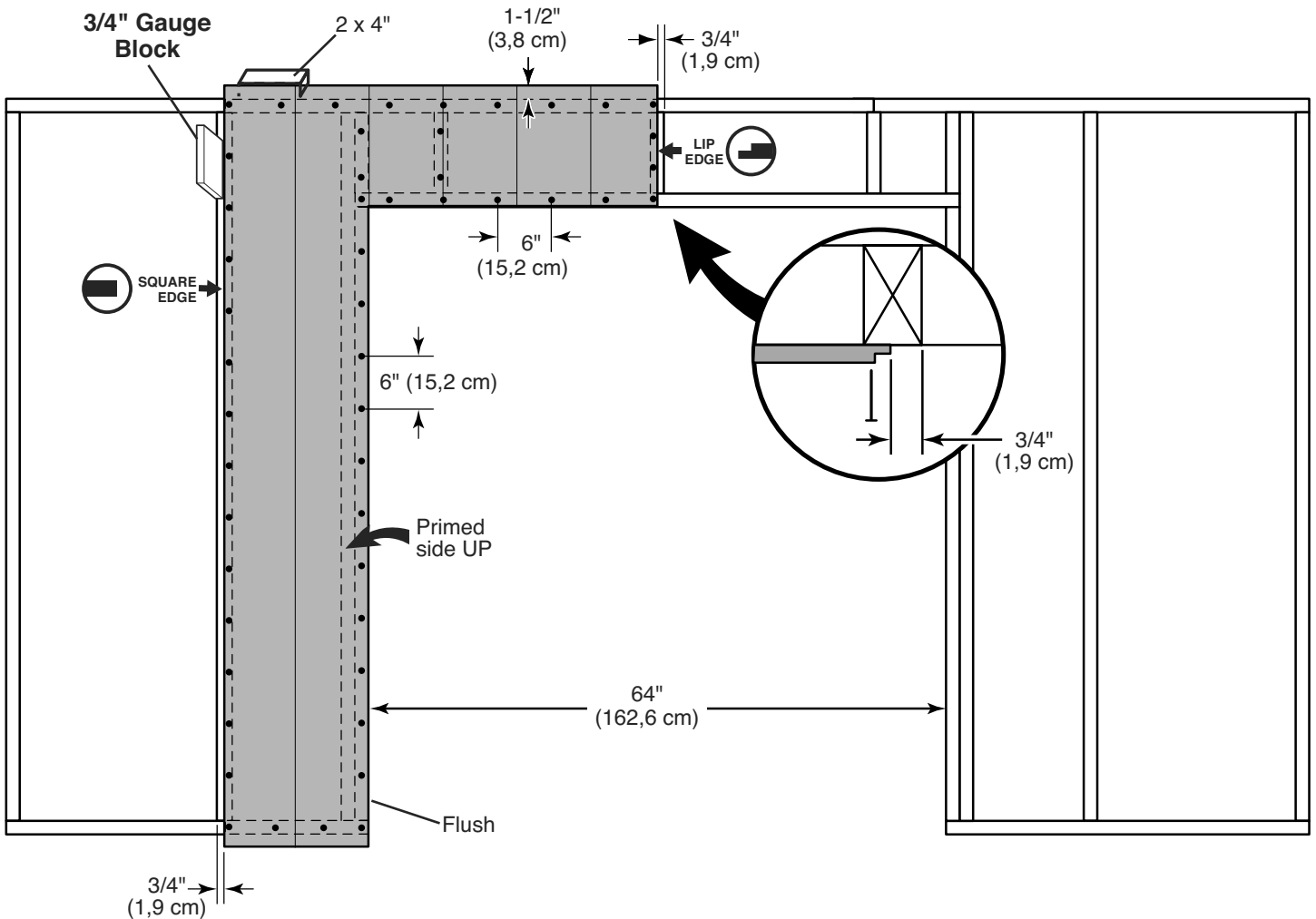

GABLE 12' x 16'

GABLE 12' x 20'

GABLE 12' x 24'

FRONT WALL PANELS

PARTS REQUIRED:

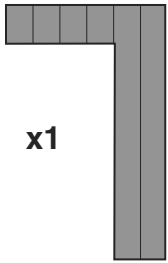

x1

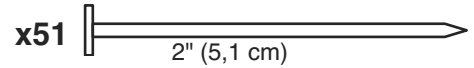

x51

2" (5,1 cm)



3/4" GAUGE
BLOCK



2 x 4 x 9"
TEMP. SPACER

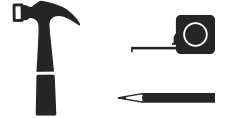

✓ BEGIN

- 1 Place the RIGHT panel onto wall frame as shown with primed side up.
- 2 Use **GAA** as a gauge block to mark the 3/4" measurement on the wall stud. Locate the panel 1-1/2" from the top plate using **UU** as a gauge block.
- 3 Nail panels to frame with two 2" nails 6" apart on edges.

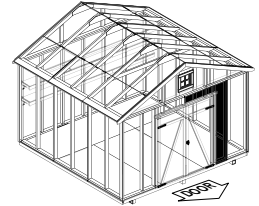

FINISH

- 4 Proceed to attaching your wing panels.

To draw panels tight at seams angle nail.



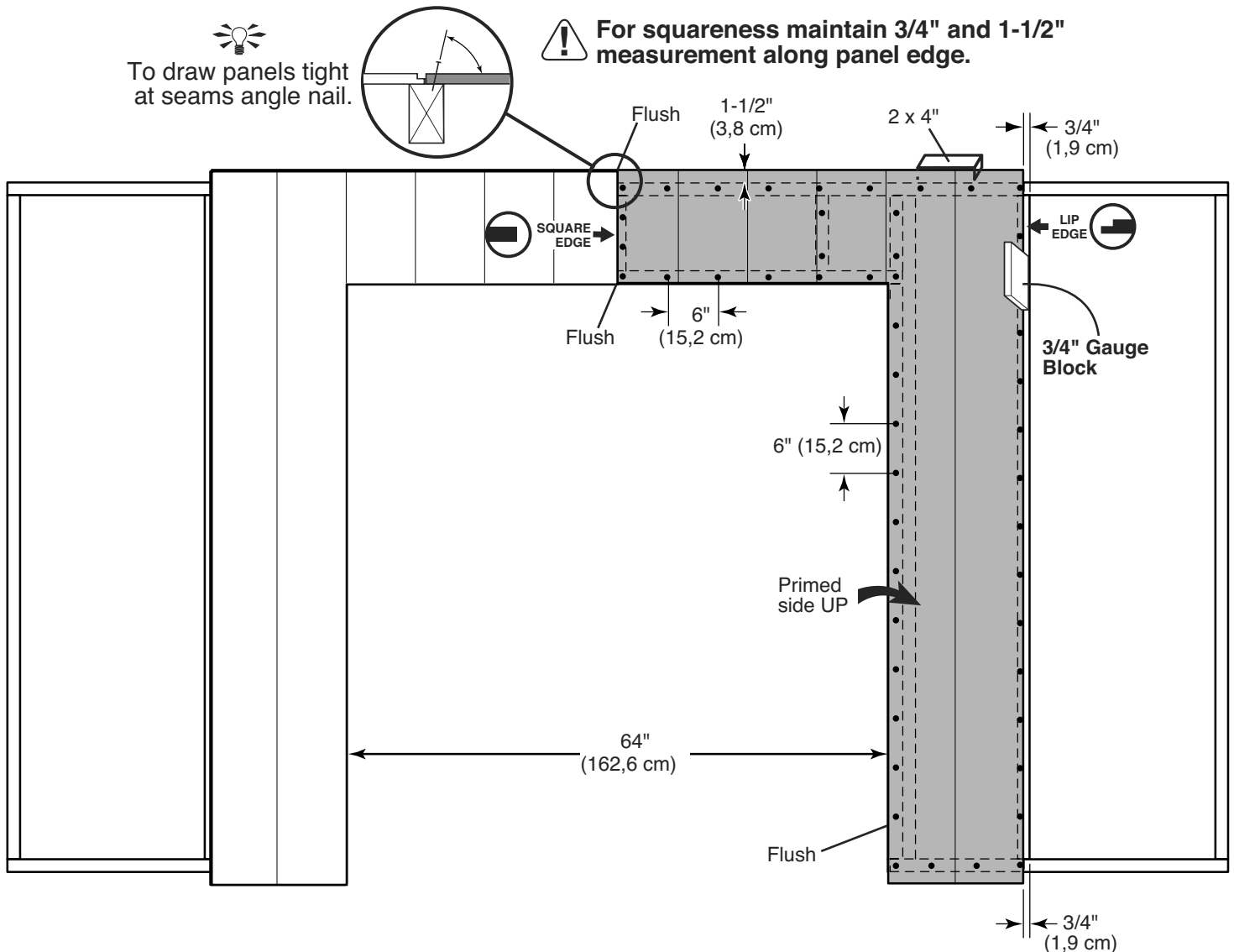

For squareness maintain 3/4" and 1-1/2" measurement along panel edge.

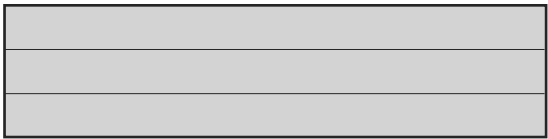

FRONT WALL WING PANELS

PARTS REQUIRED:

- x1 **TP** Temporary Support
2 x 4 x 96" (5,1 x 10,2 x 243,8 cm)
- x2 
3/8 x 23-7/8 x 84" (1 x 60,7 x 213,4 cm)

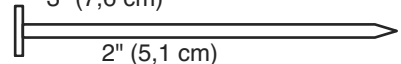
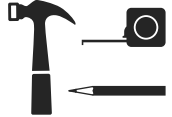
- x2 
 - x72 
- 

✓ BEGIN

- 1 Place wing wall panels onto frame with top of panels flush to previously installed panels.
- 2 Nail left and right wing wall flush to panel already attached using 2" nails 6" apart.
- 3 Attach temporary support **TP** using two 3" screws as shown.



FINISH

- 4 You have finished your front wall. **Proceed to page 40.**

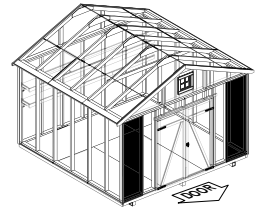

GABLE 12' x 12'

GABLE 12' x 16'

GABLE 12' x 20'

GABLE 12' x 24'

 **For squareness maintain 1-1/2" measurement along panel edge.**

 To draw panels tight at seams angle nail.

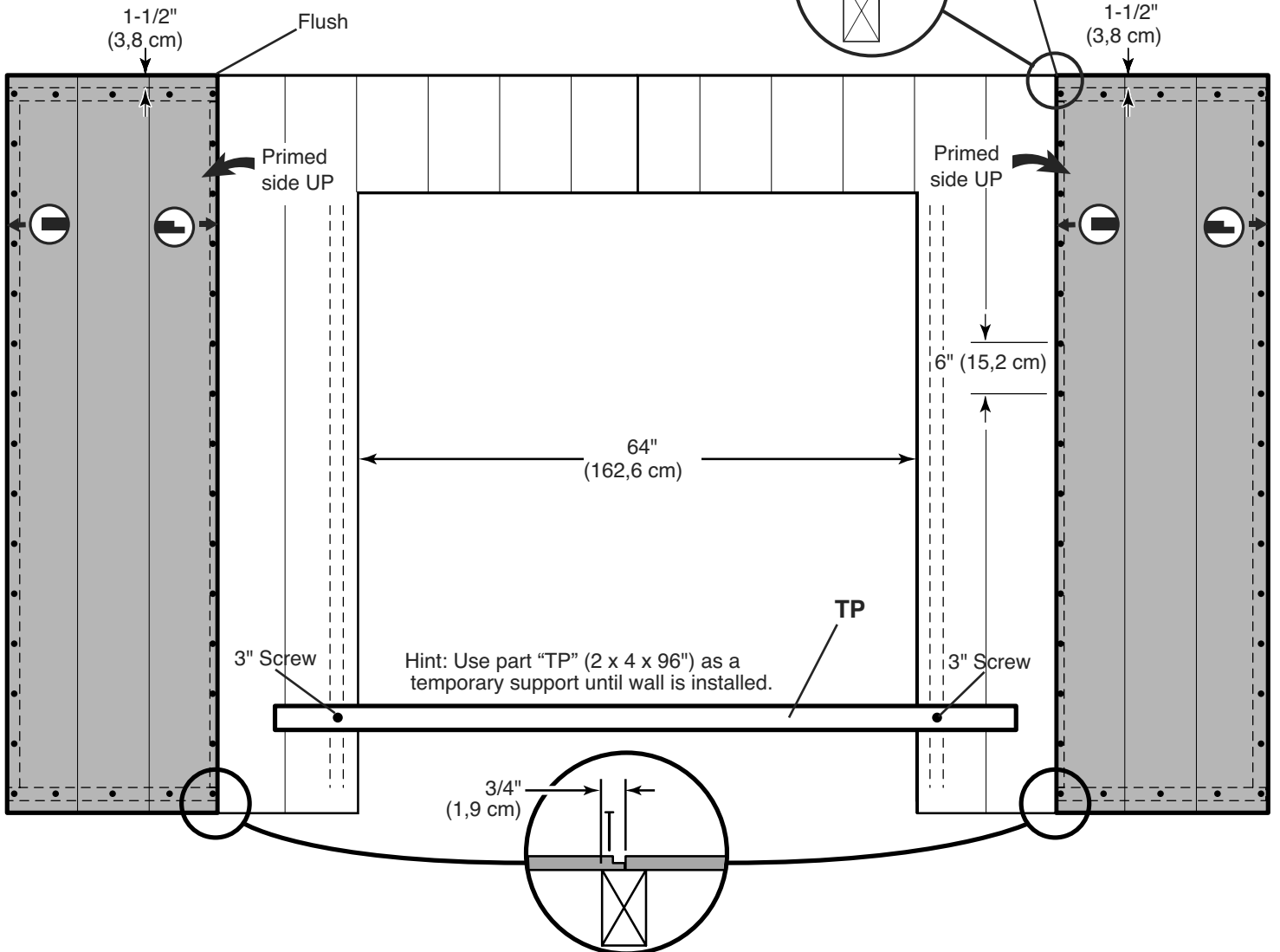

BACK WALL INSTALLATION

PARTS REQUIRED:

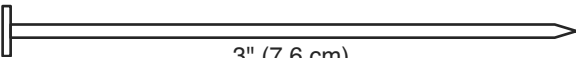
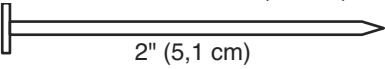
- x12  3" (7,6 cm)
- x27  2" (5,1 cm)

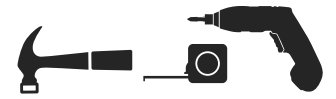
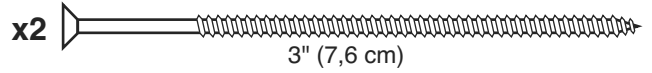

✓ **BEGIN**

1 Center back wall assembly on the 144" (365,8 cm) floor dimension. 

 Ensure 1-1/2" measurement is on top

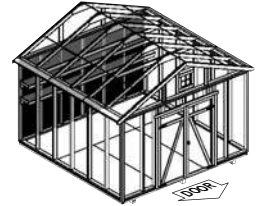

2 Use **OO** as a temporary brace. Secure with two 3" screws.

3 First, nail lower edge of panel to floor frame using 2" nails 6" apart. Angle nail to hit floor frame (**Fig. A**).

4 Nail back wall bottom plate to floor using twelve 3" nails. (Nail two 3" nails between each stud through bottom plate)



 **FINISH**

5 You have finished standing your back wall.

GABLE 12' x 12'

GABLE 12' x 16'

GABLE 12' x 20'

GABLE 12' x 24'

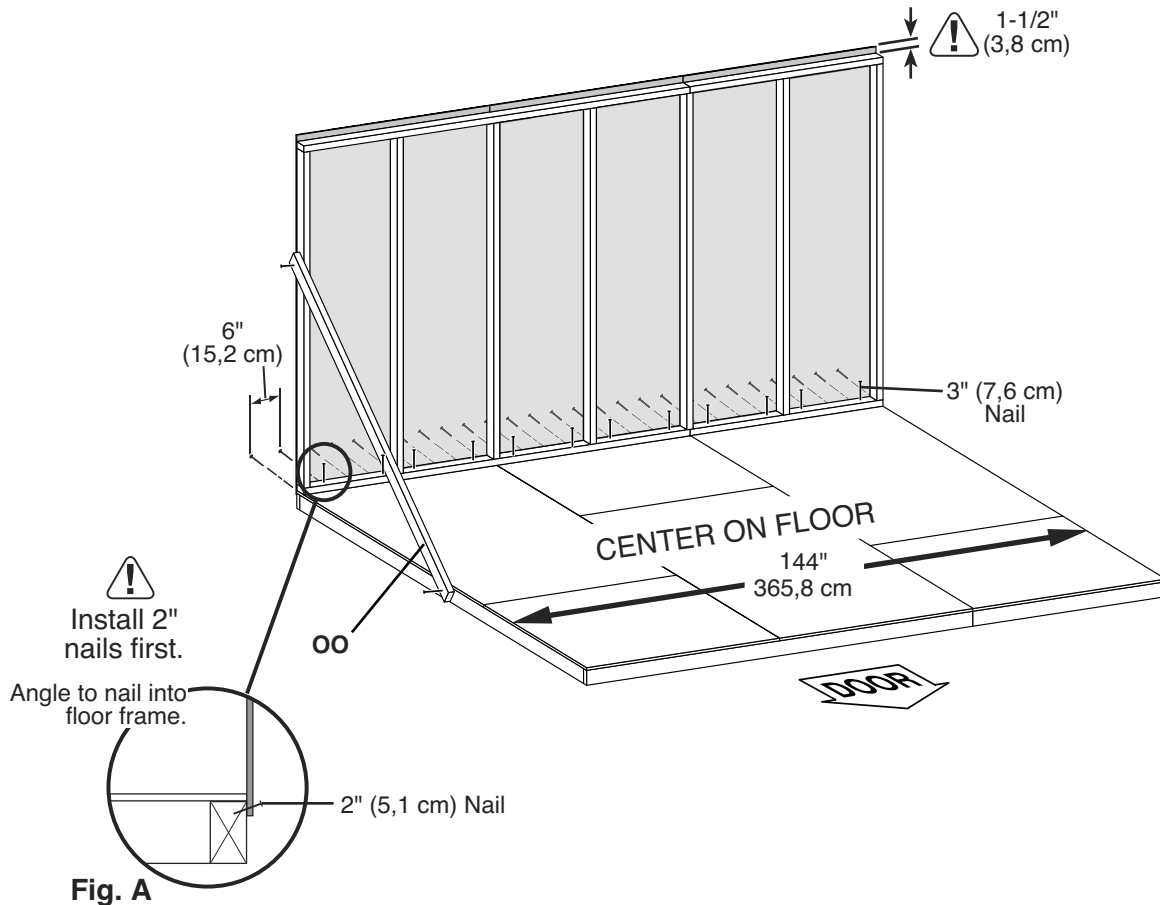
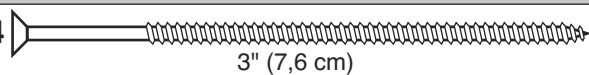
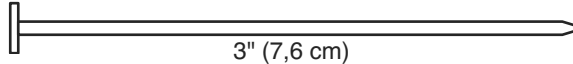

Fig. A

NOTE: 12' x 12' Model Shown.

12x12' 12x16' 12x20' 12x24' **SIDE WALLS INSTALLATION**

PARTS REQUIRED: x4  3" (7,6 cm)

x24  3" (7,6 cm)

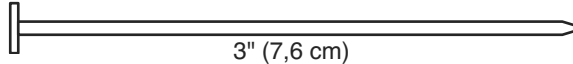
x32  3" (7,6 cm)

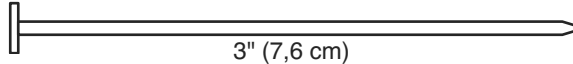
x40  3" (7,6 cm)

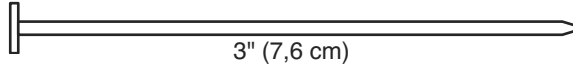
x48  3" (7,6 cm)

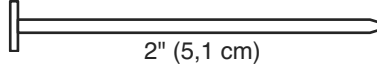
x80  2" (5,1 cm)

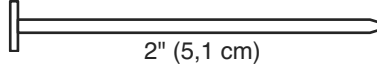
x96  2" (5,1 cm)

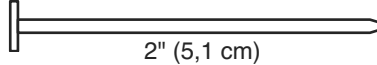
x112  2" (5,1 cm)

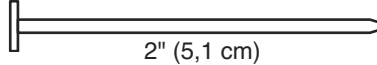
x118  2" (5,1 cm)



✓ BEGIN

Stand right sidewall on floor.

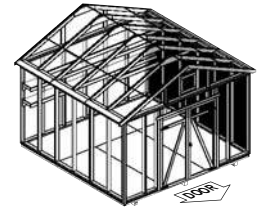

! It is important to secure the sidewall in the following order.

- 1** Center sidewall on floor front to back.

Nail the lower sidewall corner to the backwall frame with one 2" nail (**Fig. A**).

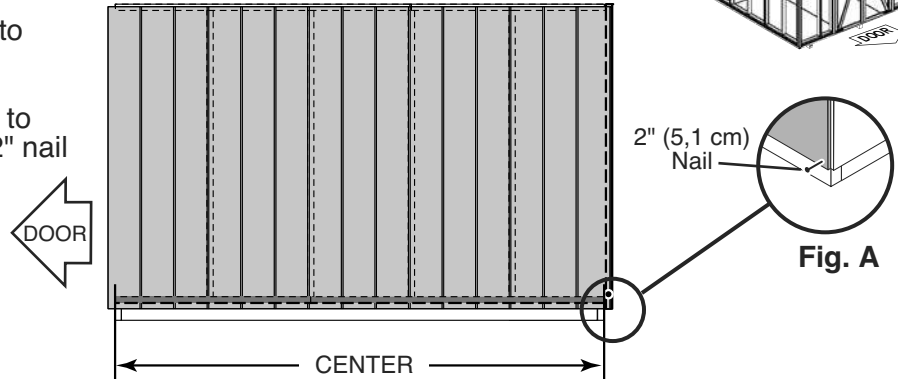

GABLE 12' x 12'

- 2** Be sure the measurement between the sidewall panel edge and the backwall panel is the same along the entire length. Then secure with one 2" nail in the upper corner (**Fig. B**).

Nail along the sidewall panel edge into the backwall frame using 2" nails spaced 6" apart.

Nail along bottom of sidewall panel using 2" nails 6" apart. Angle nail to hit floor frame (**Fig. C**).

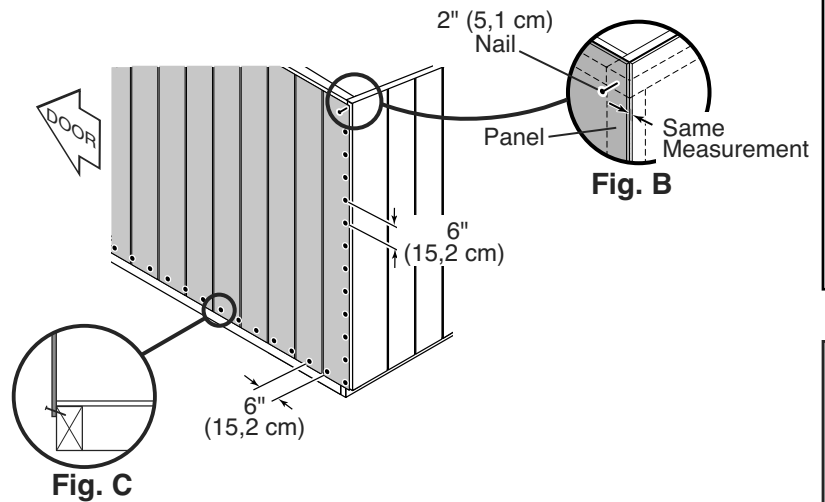

GABLE 12' x 16'

GABLE 12' x 20'

- 3** Nail down the bottom plate using two 3" nails between the wall studs.

Secure framing using two 3" screws (**Fig. D**).

Remove temporary brace. Repeat process to secure the left sidewall.

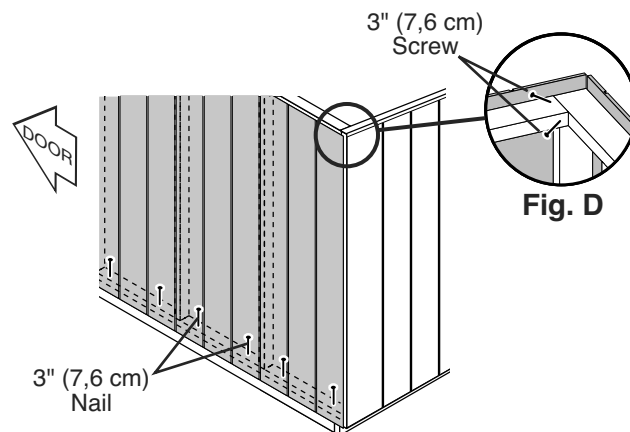

GABLE 12' x 24'

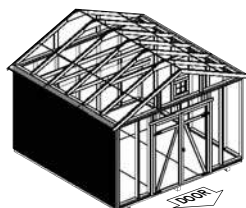

FRONT WALL INSTALLATION

PARTS REQUIRED:

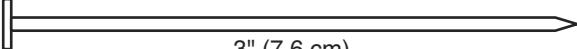
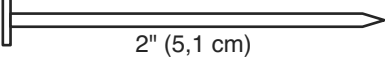
- x8 
- x26 

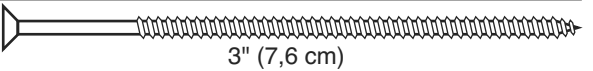
- x4 

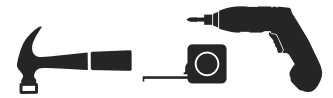

✓ BEGIN

Stand frontwall on floor.

⚠ It is important to secure the frontwall in the following order.

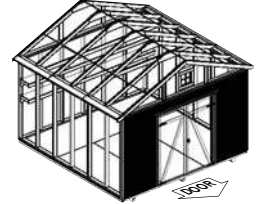

GABLE 12' x 12'

1 Center frontwall on floor side-to-side.

Nail the frontwall flush to the floor using 2" nails 6" apart. Angle nails to hit floor frame (**Fig. A**).

Nail the lower sidewall corner to the frontwall frame with one 2" nail (**Fig. B**).

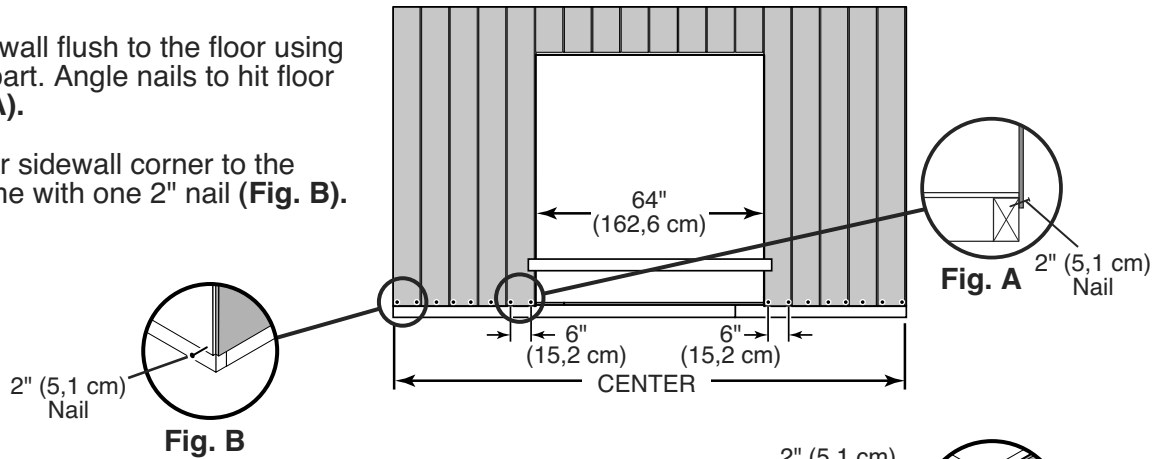

GABLE 12' x 16'

2 Be sure the measurement between the sidewall panel edge and the frontwall panel is the same along the entire length. Then secure with one 2" nail in the upper corner (**Fig. C**).

Nail along the sidewall panel edge into the frontwall frame using 2" nails spaced 6" apart.

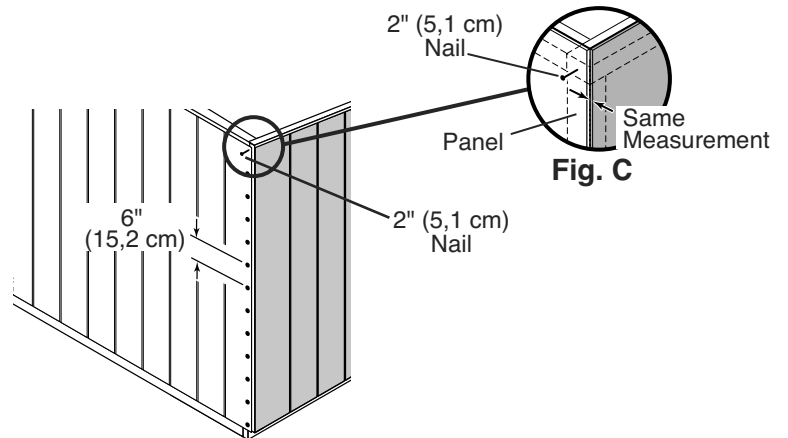

GABLE 12' x 20'

3 Secure the frontwall frame using two 3" nails (**Fig. D**).

Secure framing using two 3" screws (**Fig. E**).

Repeat process to secure the right side of the frontwall.

Remove part TP temporary brace.

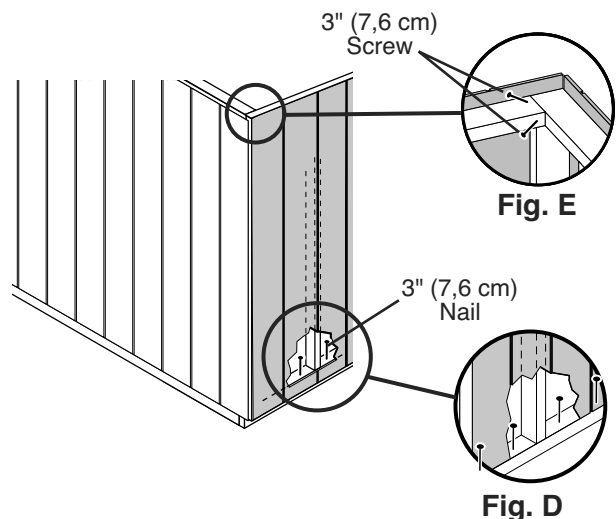

GABLE 12' x 24'

12' x 12' WALL DOUBLERS INSTALLATION

PARTS REQUIRED:

- x2 **SP** 2 x 4 x 48" (5,1 x 10,2 x 121,9 cm)
- x2 **STL** 2 x 4 x 44-1/2" (5,1 x 10,2 x 113 cm)
- x2 **TJ** 2 x 4 x 92-1/2" (5,1 x 10,2 x 235 cm)
- x2 **TP** 2 x 4 x 96" (5,1 x 10,2 x 243,8 cm)

- x64 3" (7,6 cm) Nails
- x16 3" (7,6 cm) Screws

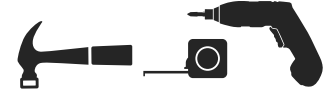

- FOR 12' x 16', SKIP TO PAGE 44
- FOR 12' x 20', SKIP TO PAGE 45
- FOR 12' x 24', SKIP TO PAGE 46

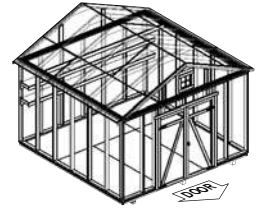

✓ BEGIN

- 1 Orient parts on top of wall frames. Measure and mark from end of boards.
- 2 Secure from top using two 3" nails spaced every 24" (Fig. A).
- 3 Secure from bottom using four 3" screws at each corner (Fig. B).

FINISH

- 4 You have finished securing the wall doublers.

GABLE 12' x 12'

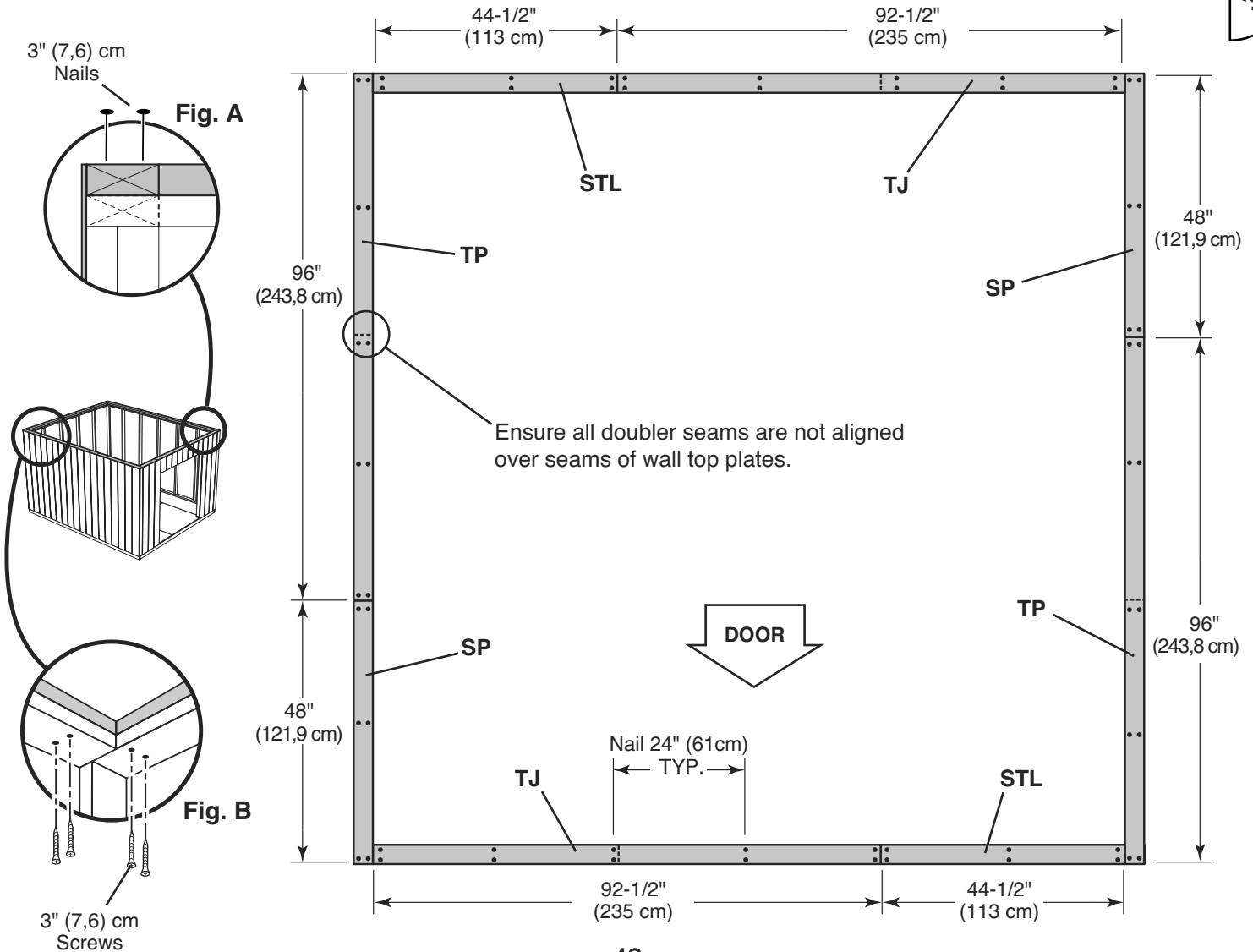

12' x 16' WALL DOUBLERS INSTALLATION

PARTS REQUIRED:

- x4 **SP**
2 x 4 x 48" (5,1 x 10,2 x 121,9 cm)
- x2 **STL**
2 x 4 x 44-1/2" (5,1 x 10,2 x 113 cm)
- x2 **TJ**
2 x 4 x 92-1/2" (5,1 x 10,2 x 235 cm)
- x2 **TP**
2 x 4 x 96" (5,1 x 10,2 x 243,8 cm)

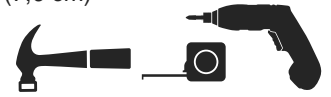
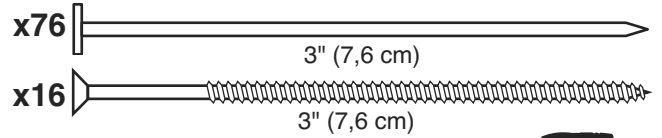

• FOR 12' x 20', SKIP TO PAGE 45
• FOR 12' x 24', SKIP TO PAGE 46

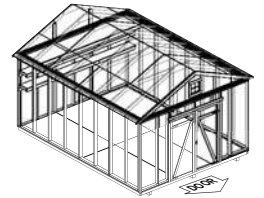

✓ BEGIN

- 1 Orient parts on top of wall frames. Measure and mark from end of boards.
- 2 Secure from top using two 3" nails spaced every 24" (Fig. A).
- 3 Secure from bottom using four 3" screws at each corner (Fig. B).



FINISH

- 4 You have finished securing the wall doublers.

GABLE 12' x 16'

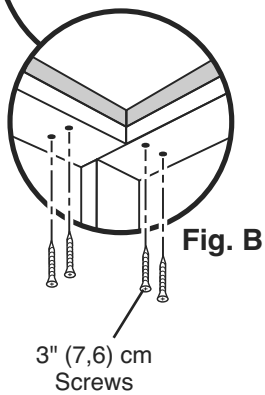
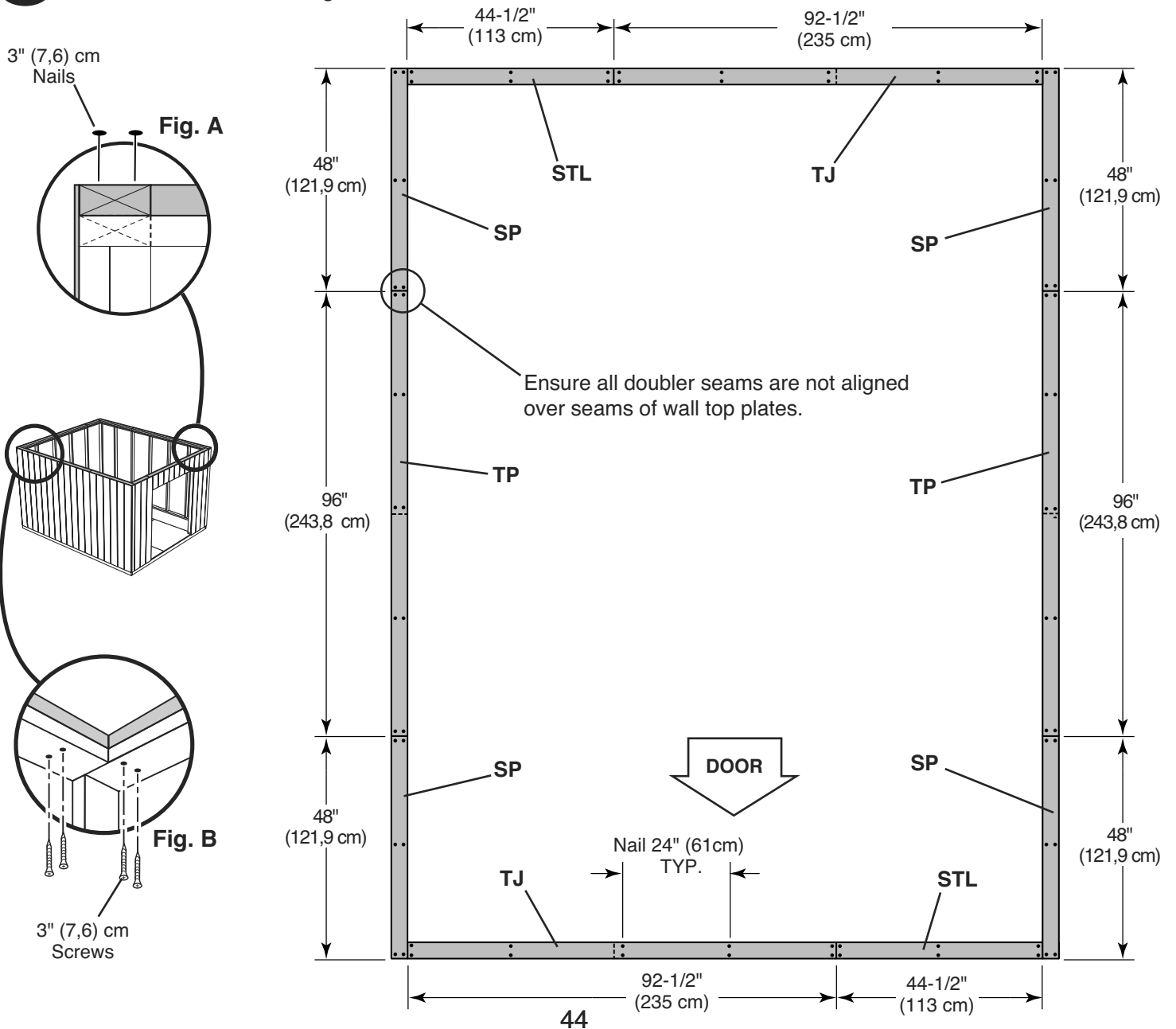

12' x 20' WALL DOUBLERS INSTALLATION

PARTS REQUIRED:

x2 **SP** 2 x 4 x 48" (5,1 x 10,2 x 121,9 cm) x2 **STL** 2 x 4 x 44-1/2" (5,1 x 10,2 x 113 cm)

x2 **TJ** 2 x 4 x 92-1/2" (5,1 x 10,2 x 235 cm)

x4 **TP** 2 x 4 x 96" (5,1 x 10,2 x 243,8 cm)

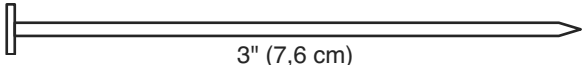
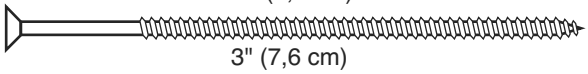
x84  3" (7,6 cm)
 x16  3" (7,6 cm)

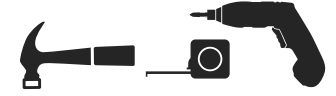

✓ BEGIN

! FOR 12' x 24', SKIP TO PAGE 46

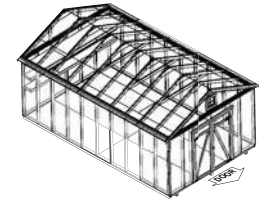

- 1 Orient parts on top of wall frames. Measure and mark from end of boards.
- 2 Secure from top using two 3" nails spaced every 24" (Fig. A).
- 3 Secure from bottom using four 3" screws at each corner (Fig. B).

FINISH

- 4 You have finished securing the wall doublers.

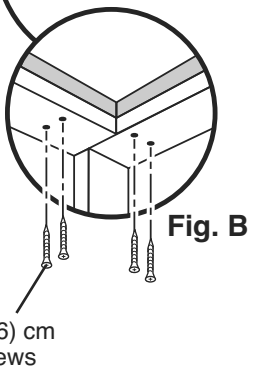
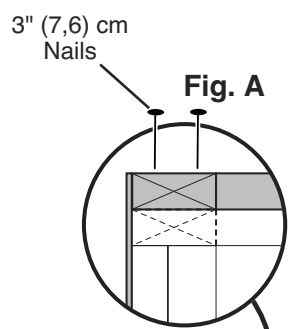
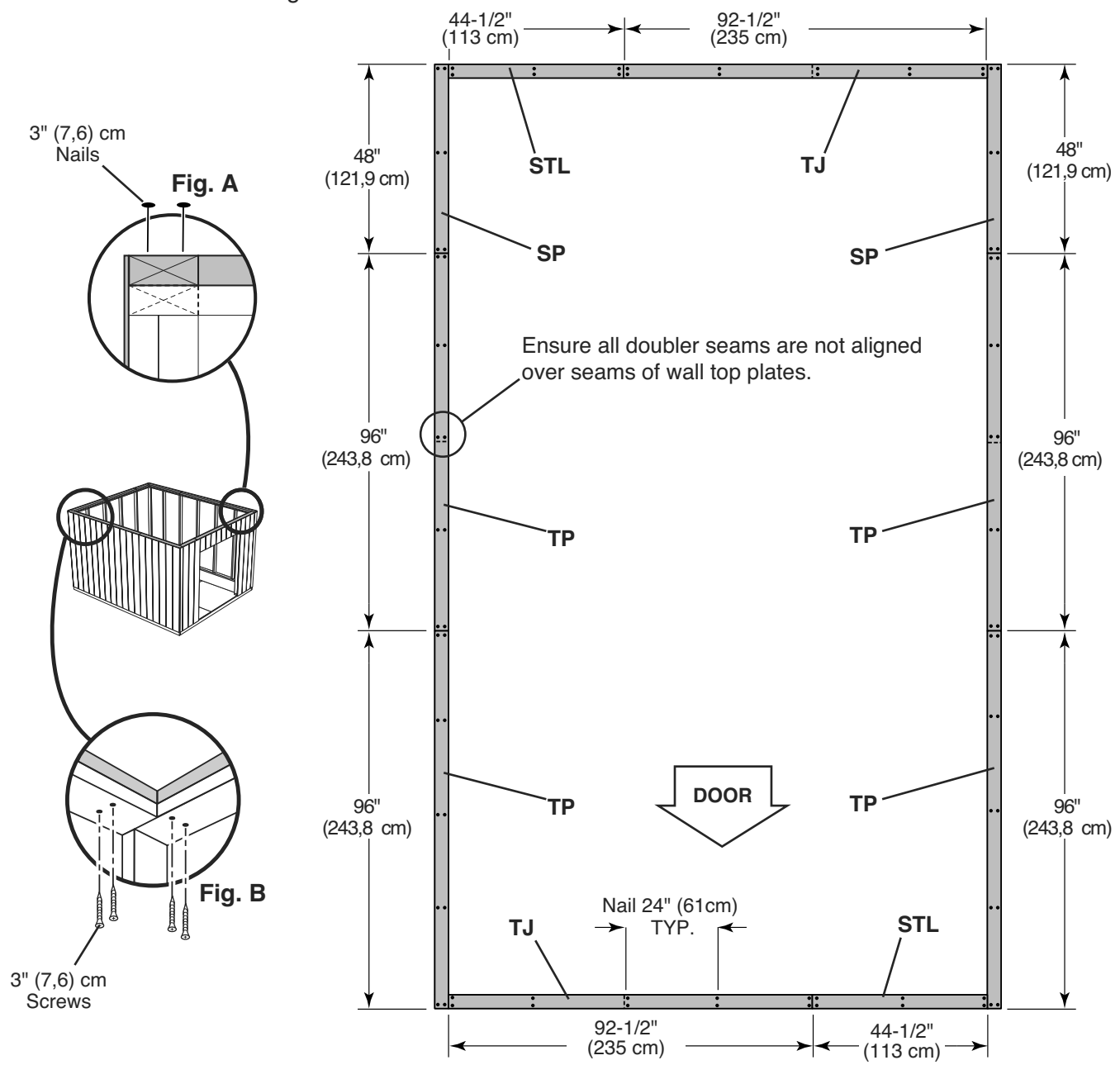

GABLE 12' x 20'

12' x 24' WALL DOUBLERS INSTALLATION

PARTS REQUIRED:

x2 **STL**
2 x 4 x 44-1/2" (5,1 x 10,2 x 113 cm)

x4 **SP**
2 x 4 x 48" (5,1 x 10,2 x 121,9 cm)

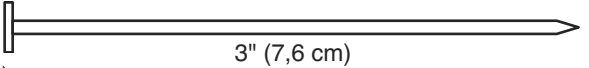
x92  3" (7,6 cm)

x2 **TJ**
2 x 4 x 92-1/2" (5,1 x 10,2 x 235 cm)

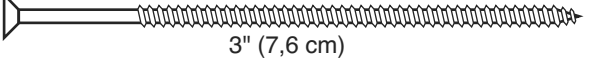
x16  3" (7,6 cm)

x4 **TP**
2 x 4 x 96" (5,1 x 10,2 x 243,8 cm)

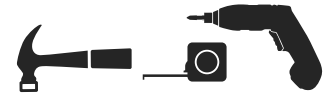

✓ BEGIN

- 1 Orient parts on top of wall frames. Measure and mark from end of boards.
- 2 Secure from top using two 3" nails spaced every 24" (Fig. A).
- 3 Secure from bottom using four 3" screws at each corner (Fig. B).

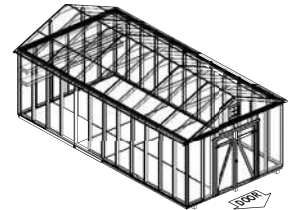

FINISH

- 4 You have finished securing the wall doublers.

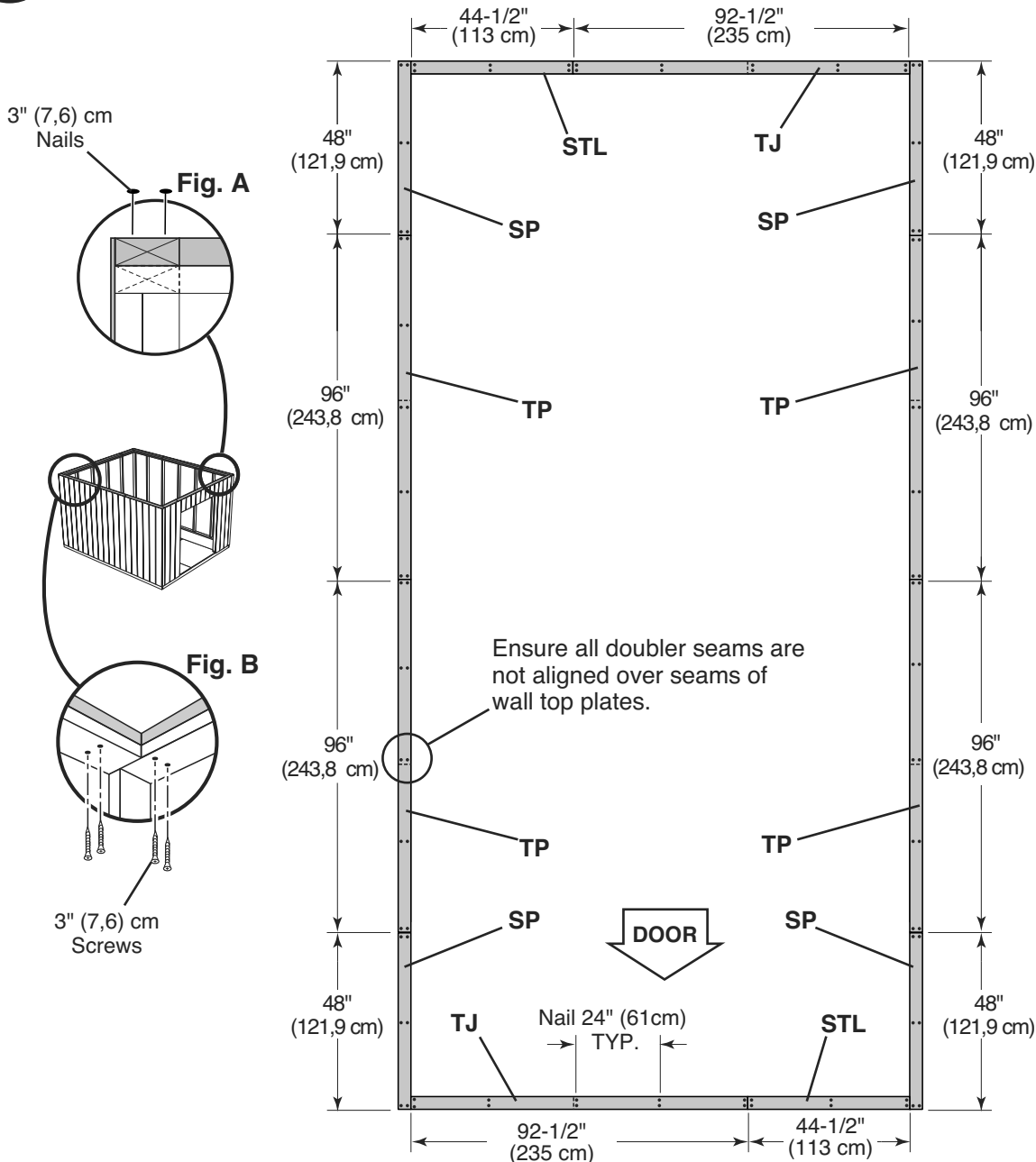

12x12'				12x16'				12x20'				12x24'				RAFTERS																			
PARTS REQUIRED:																x1 OO																			
x12																x16				x20				x24				6 x 24" (15,2 x 61 cm)				2 x 3 x 69" (5,1 x 7,6 x 175,3 cm) Temp Support			
x14																x18				x22				x26				ADA				2 x 4 x 77-15/16" (5,1 x 10,2 x 198 cm)			
x144																x192				x240				x288				2" (5,1 cm)							

BEGIN

1 Place two rafter-halves (**ADA**) in the corner of back and side walls. Rafters contact at peak.

You will build **TWO** assemblies with **ONE** gusset. All other assemblies will have **TWO** gussets, depending on the size of your building.

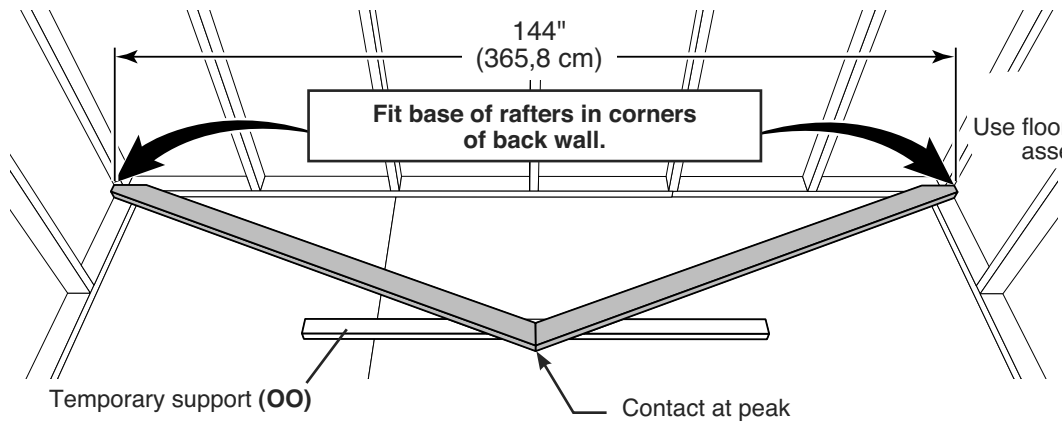
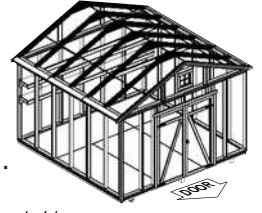

HINT: Use floor and walls to help assemble rafters!

GABLE 12' x 12'

GABLE 12' x 16'

GABLE 12' x 20'

GABLE 12' x 24'

- 2** Apply glue to rafters where gusset will fit.
- 3** Secure gusset to rafters using 2" (5,1 cm) Nails as shown.
- 4** Flip over rafter assembly and repeat **STEPS 2-4** to attach second gusset to other side.
- SET TWO RAFTER ASSEMBLIES ASIDE WITH ONLY ONE GUSSET ATTACHED**
- 5** Repeat **STEPS 1-4** to build additional assemblies. Remove **OO**.

FINISH

6 You have finished assembling your rafters.

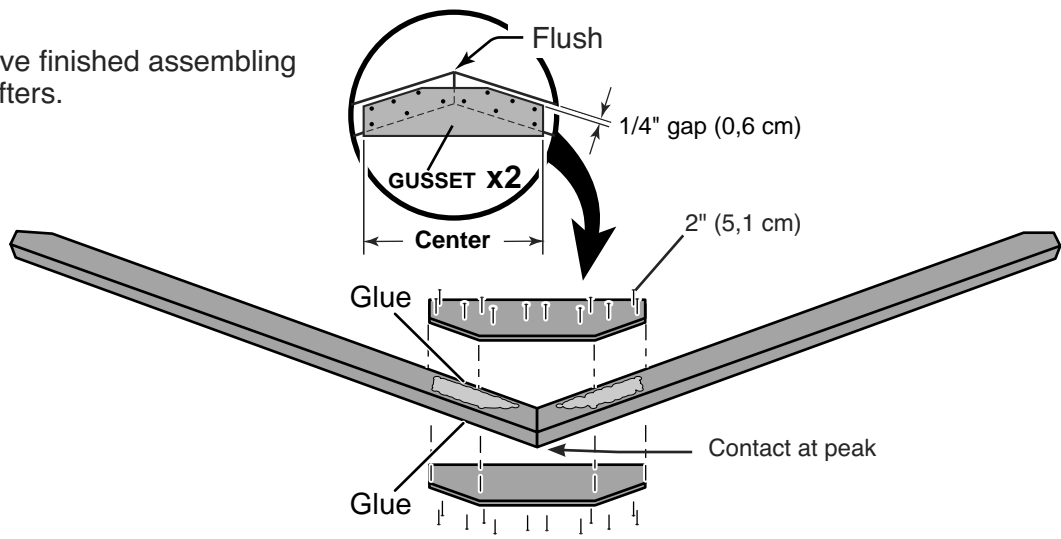

12' x 12' RAFTER INSTALLATION

PARTS REQUIRED:

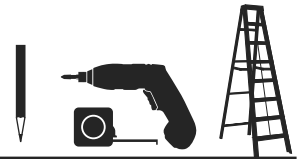
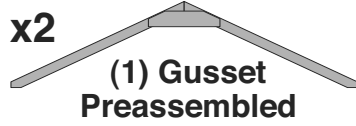
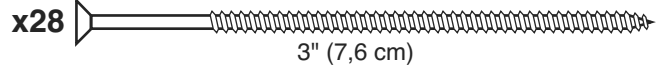

- FOR 12' x 16', SKIP TO PAGE 49
- FOR 12' x 20', SKIP TO PAGE 50
- FOR 12' x 24', SKIP TO PAGE 51



GABLE 12' x 12'

✓ BEGIN

1 Locate rafters directly over the wall studs. Check you have the measurements shown.

2 Secure with two 3" screws angled at each end (Fig. A, B).

FINISH

3 You have finished installing your rafters. Proceed to page 52.

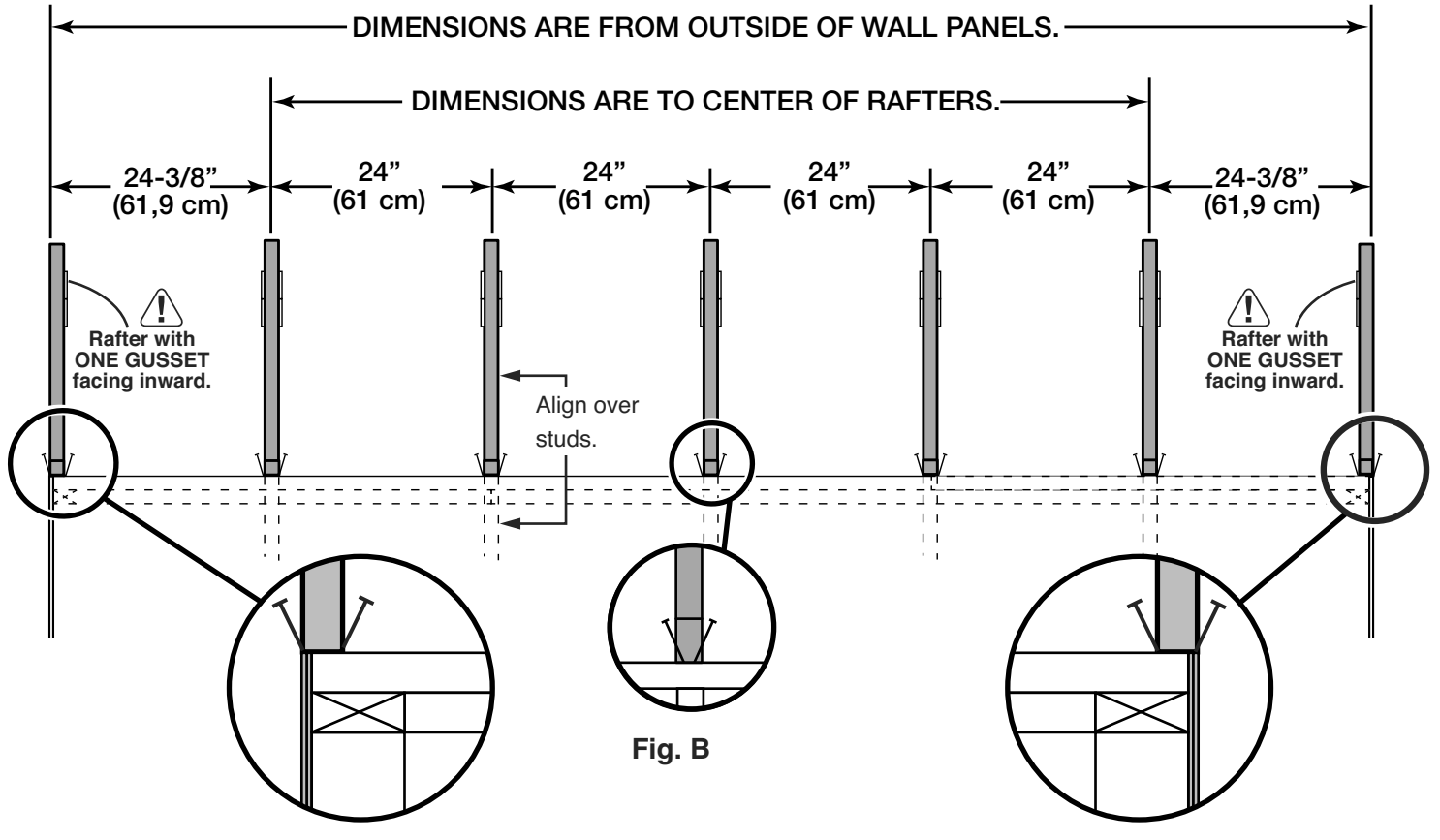

Maintain the measurements between rafters.

12' x 16' RAFTER INSTALLATION

PARTS REQUIRED:

x36  3" (7,6 cm)

x7 
(2) Gusset
Preassembled

x2 
(1) Gusset
Preassembled

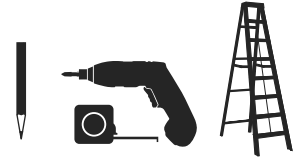

• FOR 12' x 20', SKIP TO PAGE 50

• FOR 12' x 24', SKIP TO PAGE 51

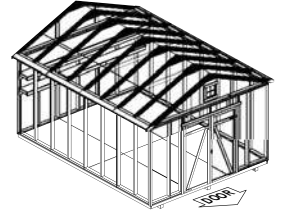

✓ BEGIN



1 Locate rafters directly over the wall studs.
Check you have the measurements shown.

2 Secure with two 3" screws angled at each end (Fig. A, B).

FINISH

3 You have finished installing your rafters. Proceed to page 52.

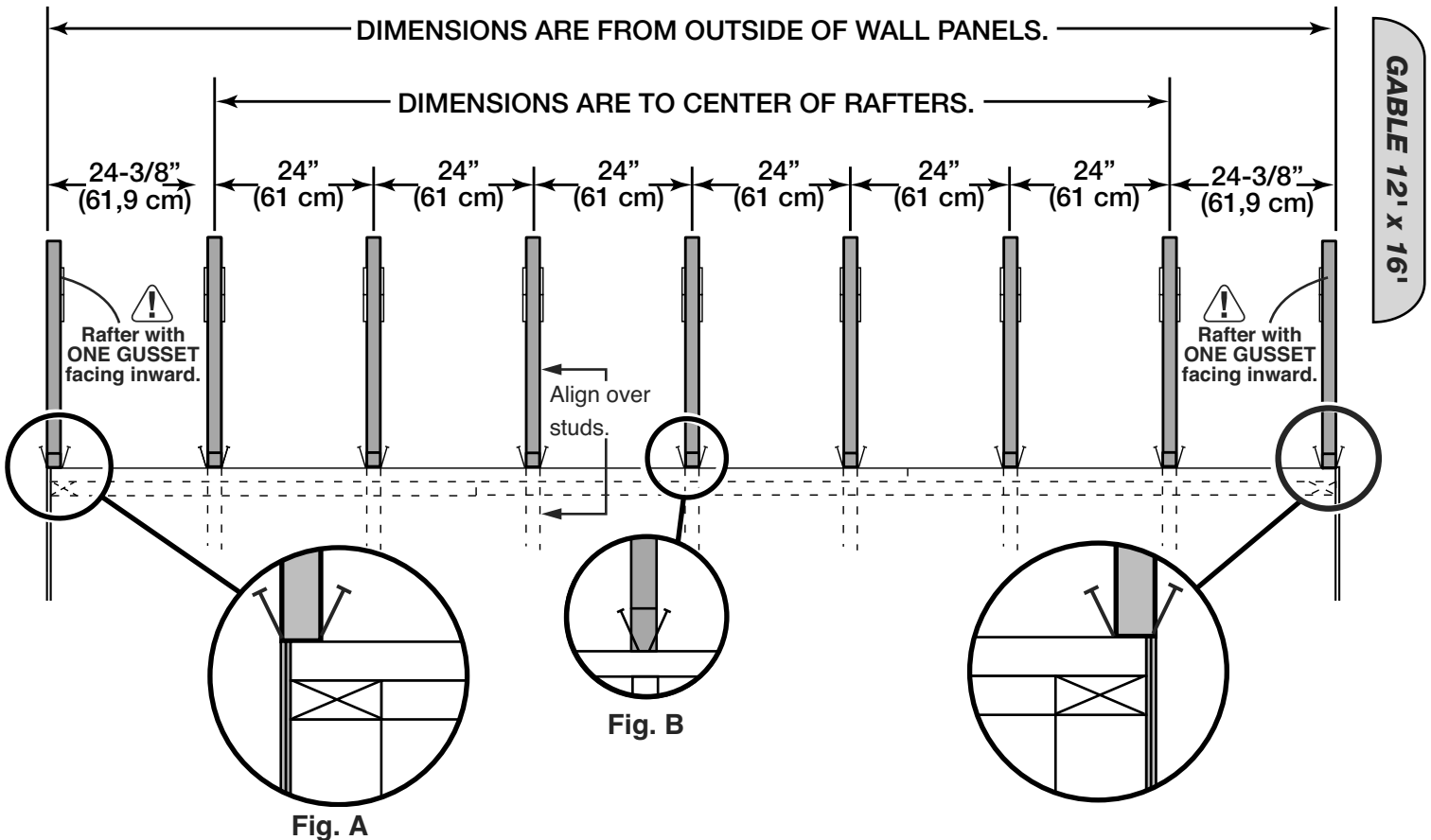



Maintain the measurements between rafters.

12' x 20' RAFTER INSTALLATION

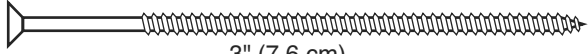
PARTS REQUIRED:

x44  3" (7,6 cm)

x9  (2) Gusset Preassembled

x2  (1) Gusset Preassembled



• FOR 12' x 24', SKIP TO PAGE 51

✓ BEGIN

1 Locate rafters directly over the wall studs.
Check you have the measurements shown.

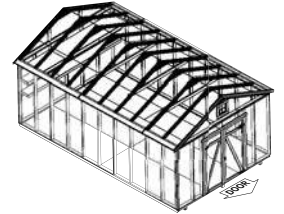

2 Secure with two 3" screws angled at each end (Fig. A, B).

FINISH

3 You have finished installing your rafters. Proceed to page 52.

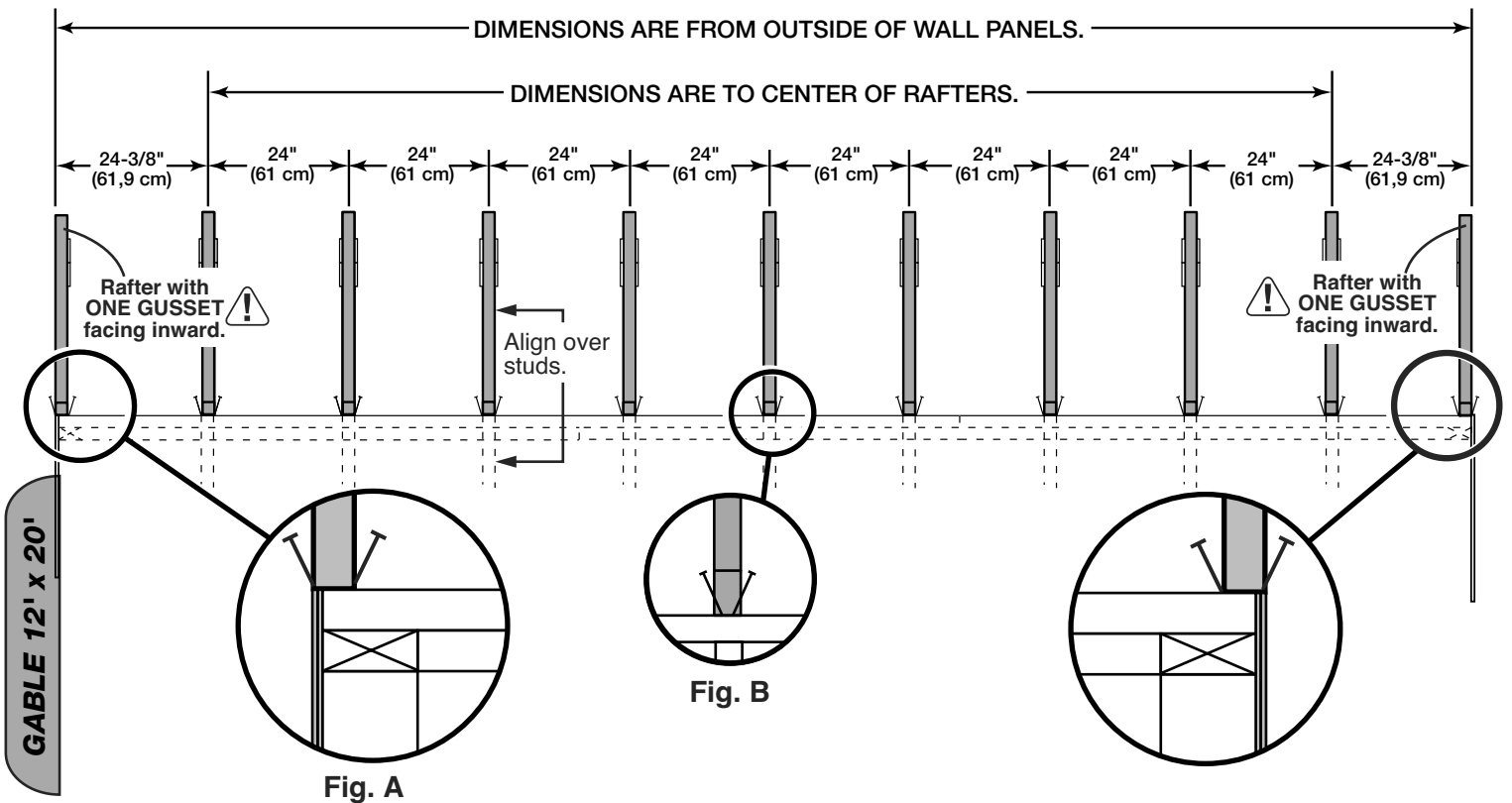

Maintain the measurements between rafters.

12' x 24' RAFTER INSTALLATION

PARTS REQUIRED:

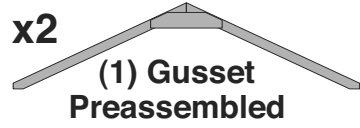
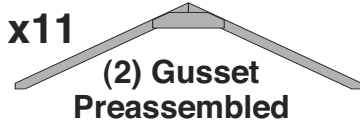
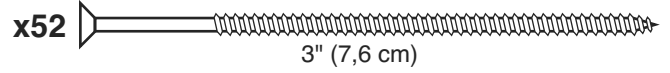

✓ BEGIN

1 Locate rafters directly over the wall studs. Check you have the measurements shown. 

2 Secure with two 3" screws angled at each end (Fig. A, B).

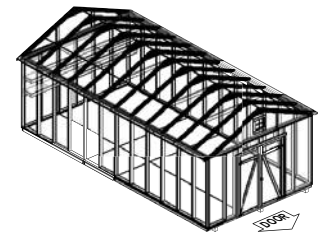

FINISH

3 You have finished installing your rafters. Proceed to page 52.

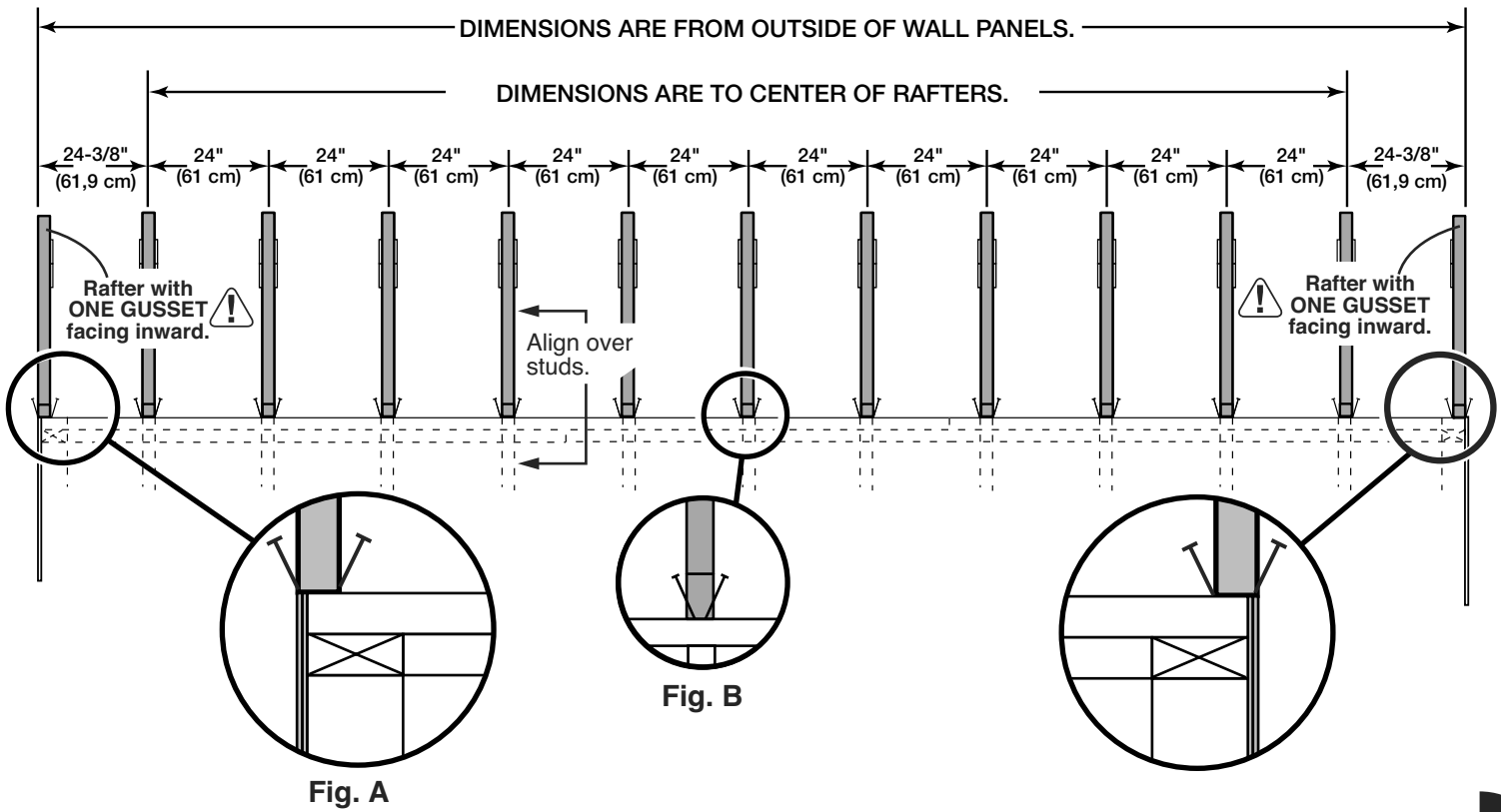

 Maintain the measurements between rafters.

GABLE PANELS

PARTS REQUIRED:

x4 **AF**
2 x 4 x 18-1/8" (5,1 x 10,2 x 46 cm)

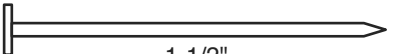
x24 
1-1/2"
(3,8cm)

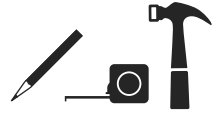
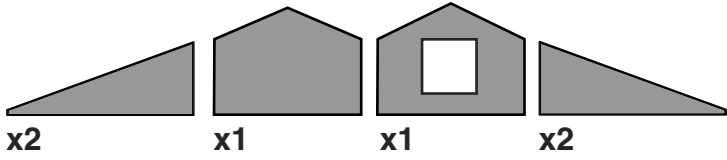

✓ BEGIN

- 1 Place center gable panel on **AF** primed side up as shown.
- 2 Mark bottom of center gable panel at center on primed side.
- 3 Place left panel on **AF** flush to center gable panel and secure using three 1-1/2" nails.
- 4 Repeat **STEP 3** for right panel.
- 5 Repeat **STEP 1-4** for front gable panels.

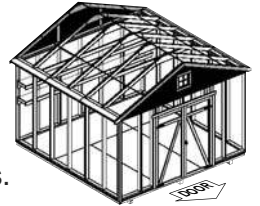

GABLE 12' x 12'

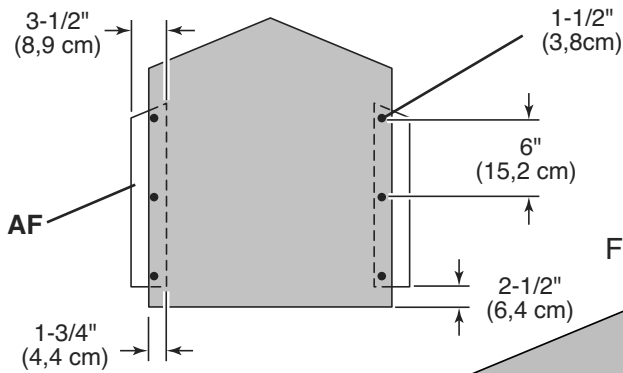

GABLE 12' x 16'

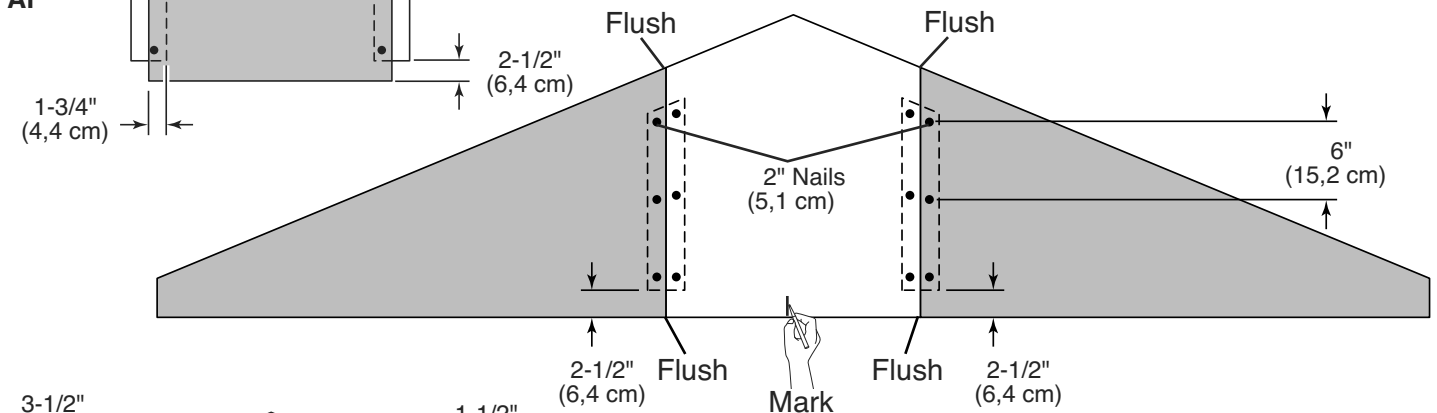

GABLE 12' x 20'

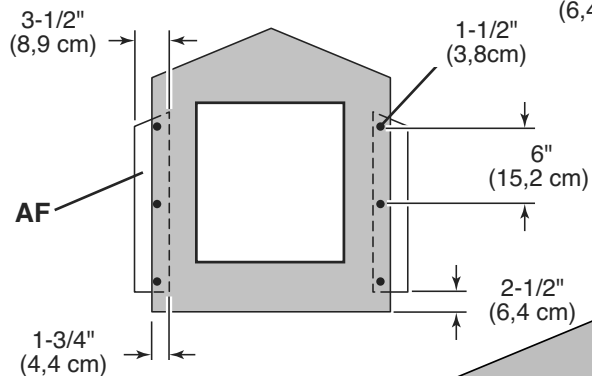

GABLE 12' x 24'

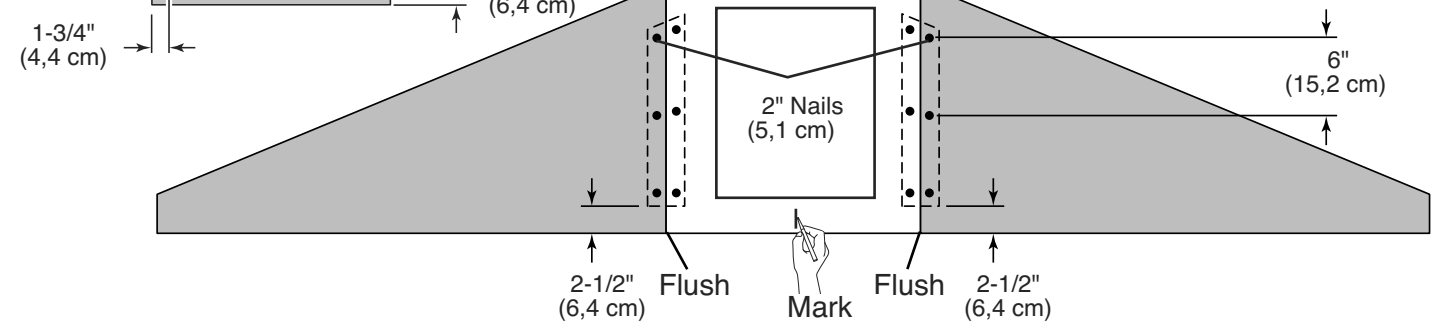

GABLE INSTALLATION

PARTS REQUIRED:

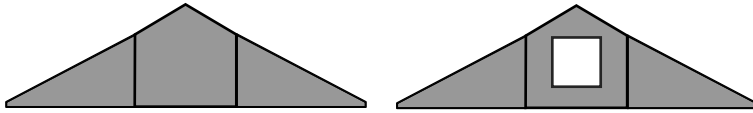

Pre - assembled

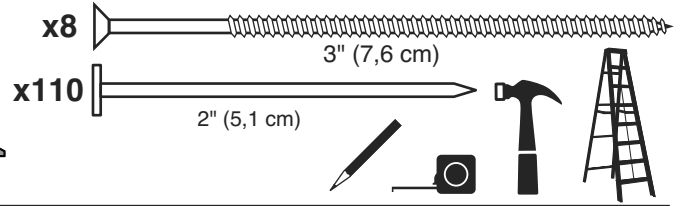

6 Center gable assembly on back wall and overlap back wall.
Nail using 2" nails 6" apart as shown.

7 Repeat **STEP 6** for front gable.

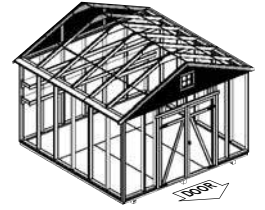

8 You have finished installing your gable panels.

BACK GABLE ASSEMBLY

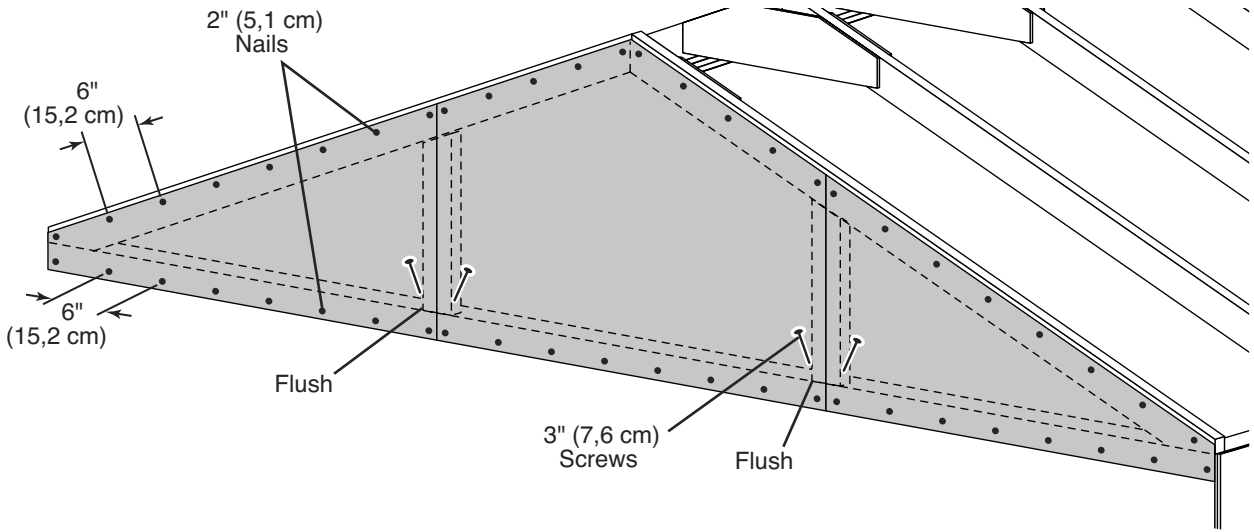

GABLE 12' x 12'

GABLE 12' x 16'

FRONT GABLE ASSEMBLY

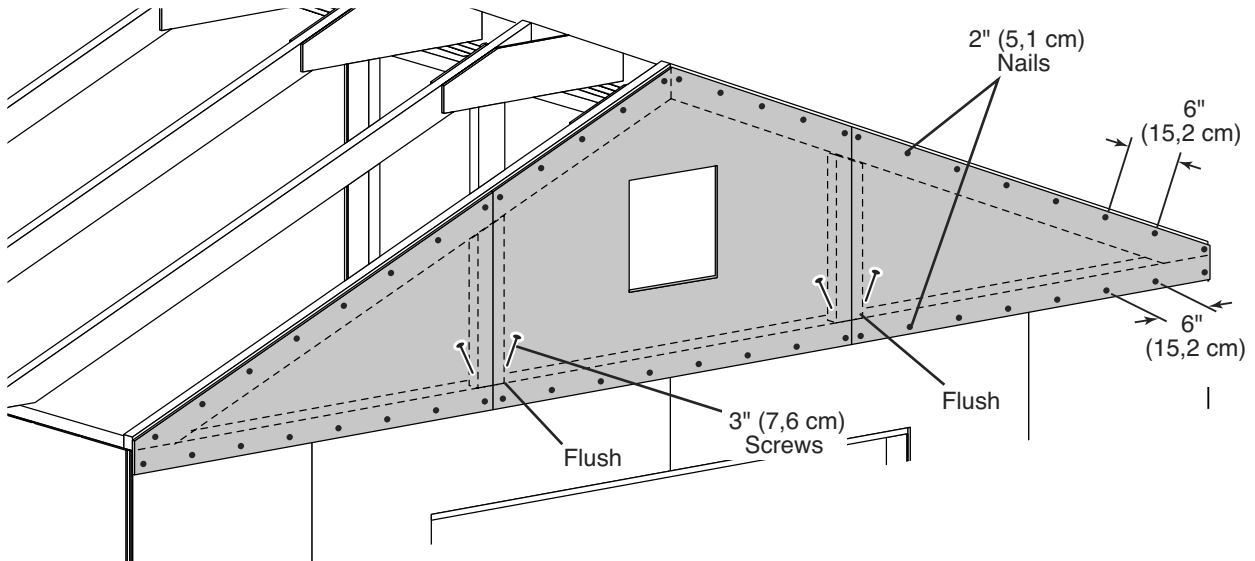

GABLE 12' x 20'

GABLE 12' x 24'

12' X 12' ROOF PANELS

PARTS REQUIRED:

x2



7/16 x 48 x 96"
(1,1 x 121,9 x 243,8 cm)

x8

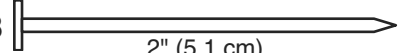

2" (5,1 cm)

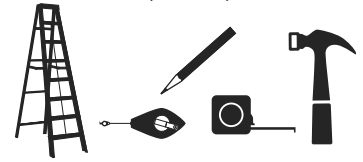

- FOR 12' x 16', SKIP TO PAGE 56
- FOR 12' x 20', SKIP TO PAGE 58
- FOR 12' x 24', SKIP TO PAGE 60

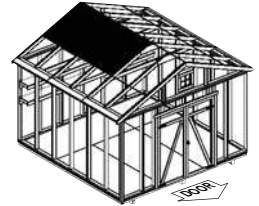

Roof panels may cause serious injury until securely fastened.



You must square the roof by attaching one panel first. You must use the panel's long edge as a lever to bring your roof into square. Commonly known as "racking".

✓ BEGIN

1

Attach panel to end of rafter with rough side up (Primed grid-line side) 1/2" (1,3 cm) from edge of trim (**Fig. A**) and panel flush at peak (**Fig. B**).

Secure with two 2" nails at the corners.

Fig. A

3/4"
(1,9 cm)

Roof Panel
Rafter
Gabel Panel
Fig. D

1/2"
(1,3 cm)

Fig. B

Fig. C

2

Move to the opposite end. Using the long edge of the panel as a lever, move the panel side-to-side until the top corner is flush with the peak (**Fig. C**), and there is 1/2" measurement to the rafter (**Fig. D**).

You may need to adjust your back wall gable panel for 1/2" measurement. Secure panel with two 2" nails in the corners.

2" Nails
(5,1 cm)

GABLE 12' x 12'

12' X 12' ROOF PANELS

PARTS REQUIRED:

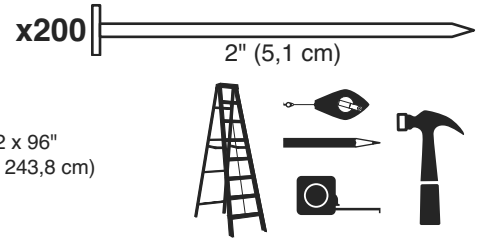
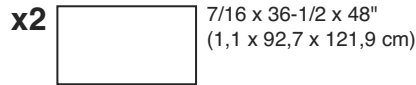
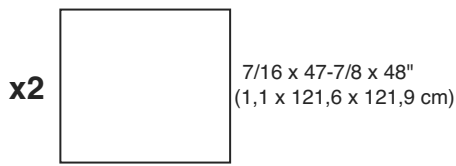

- 3** Keep spacing between the center of each rafter at the lower edge of the panel and secure with one 2" nail into each rafter (**Fig. E**).

Move to the top of the panel and keep spacing between the center of the rafters. Secure with one 2" nail into each rafter (**Fig. E**).

Nail the roof panel using 2" nails 6" apart on edges and 12" apart inside panel.

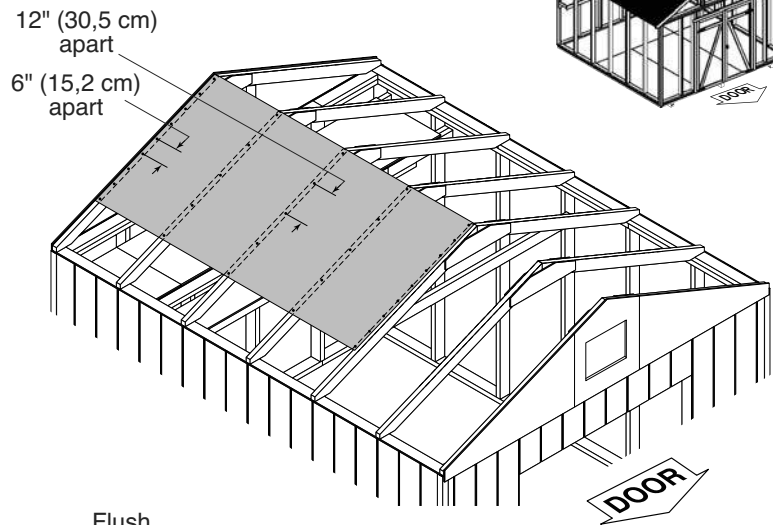
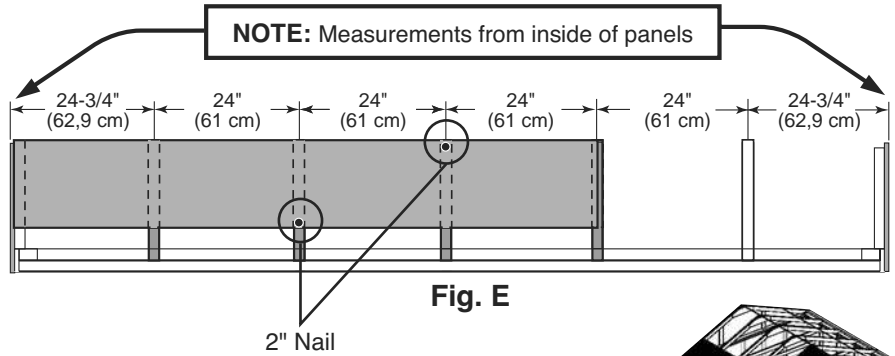

- 4** Attach the lower roof panel flush to the upper panel, with the 1/2" measurement at the rafter (**Fig. G**).

Nail the roof panel using 2" nails 6" apart on edges and 12" apart inside panel.

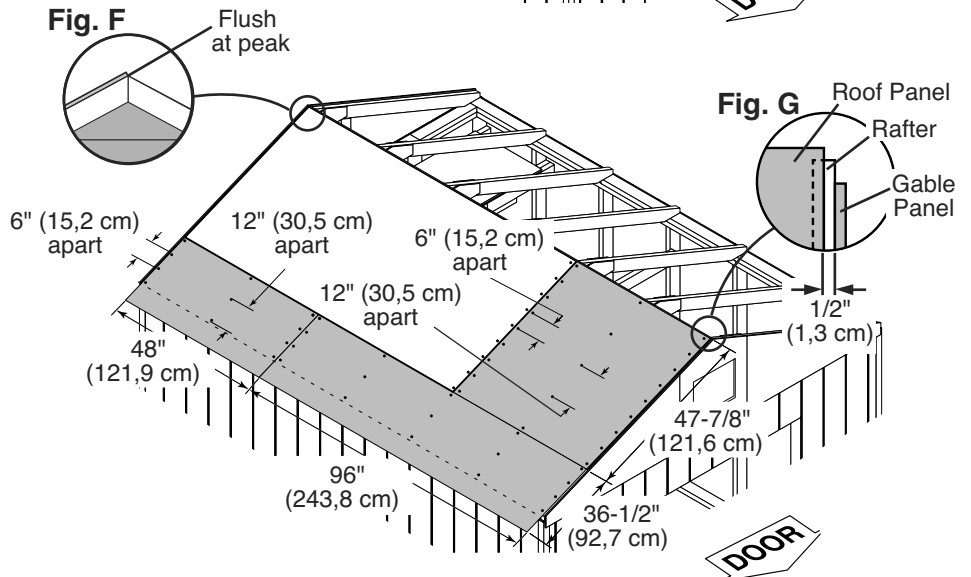

- 5** Repeat process to attach roof panels on the opposite side. **Proceed to page 62.**

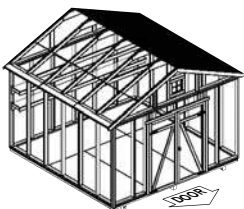

GABLE 12' X 12'

12' X 16' ROOF PANELS

PARTS REQUIRED:

x2



7/16 x 48 x 96"
(1,1 x 121,9 x 243,8 cm)

GAA
3/4"
GAUGE BLOCK

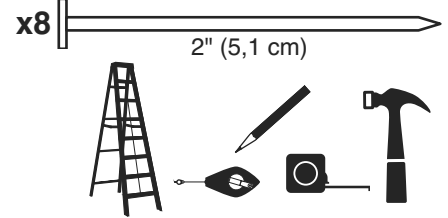

• FOR 12' x 20', SKIP TO PAGE 58

• FOR 12' x 24', SKIP TO PAGE 60

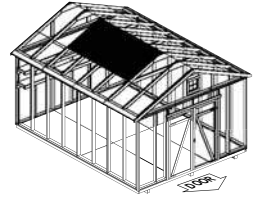

Roof panels may cause serious injury until securely fastened.



You must square the roof by attaching one panel first. You must use the panel's long edge as a lever to bring your roof into square. Commonly known as "racking".

✓ **BEGIN**

1

Attach panel with the rough side up (painted-grid lines side) with a 3/4" (1,9 cm) measurement on the rafter (**Fig. A**) and the panel flush at the peak (**Fig. B**).

Secure panel with two 2" nails in the corners.

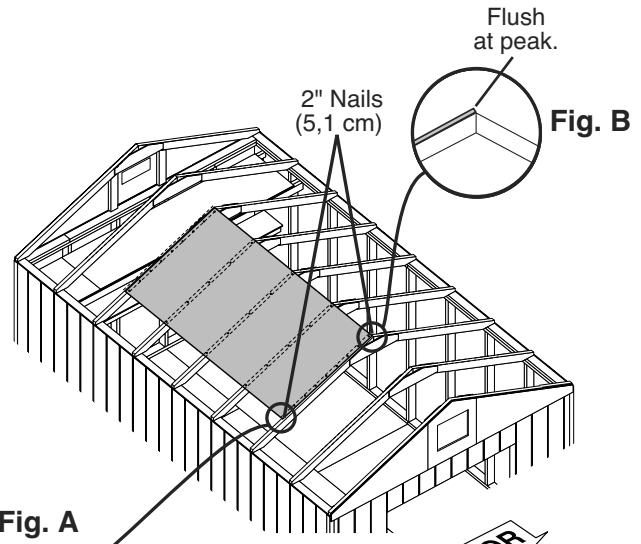

Fig. A

Fig. B

2

Move to the opposite end. Using the long edge of the panel as a lever move the panel side-to-side until the top corner is flush to the peak (**Fig. C**).

Secure panel with two 2" nails in the corners.

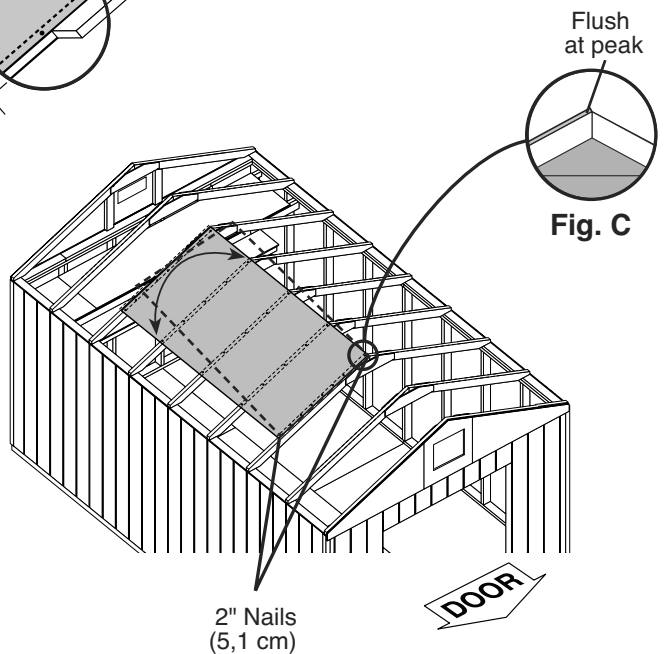



Fig. C

GABLE 12' x 16'

12' X 16' ROOF PANELS

PARTS REQUIRED:

x4  7/16 x 47-7/8 x 48"
(1,1 x 121,6 x 121,9 cm)

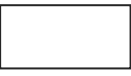
x4  7/16 x 36-1/2 x 48"
(1,1 x 92,7 x 121,9 cm)

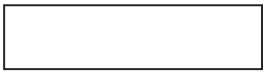
x2  7/16 x 36-1/2 x 96"
(1,1 x 92,7 x 243,8 cm)

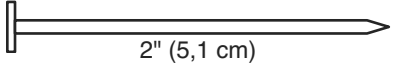
x282  2" (5,1 cm)

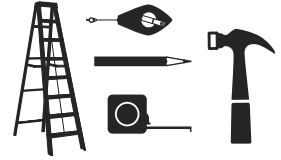

3 Keep spacing between the center of each rafter at the lower edge of the panel and secure with one 2" nail into each rafter (**Fig. E**).

Move to the top of the panel and keep spacing between the center of the rafters. Secure with one 2" nail into each rafter (**Fig. E**).

Nail the roof panel using 2" nails 6" apart on edges and 12" apart inside panel.

4 Attach the two 48 x 48" roof panel flush to the upper panel and roof peak (**Fig. F**), with a 1/2" measurement at the rafter (**Fig. G**).

Nail the roof panel using 2" nails 6" apart on edges and 12" apart inside panel.

5 Attach the 36-1/2 x 48" lower roof panel flush to the upper panel (**Fig. F**), with the 1/2" (1,3 cm) measurement at the rafter (**Fig. G**).

Nail the roof panel using 2" nails 6" apart on edges and 12" apart inside panel.

6 Attach the two 36-1/2 x 96" lower roof panels flush to the upper panel, with the 1/2" (1,3 cm) measurement at the rafter (**Fig. G**).

Nail the roof panel using 2" nails 6" apart on edges and 12" apart inside panel.

FINISH

7 Repeat process to attach roof panels on the opposite side.
Proceed to Page 62.

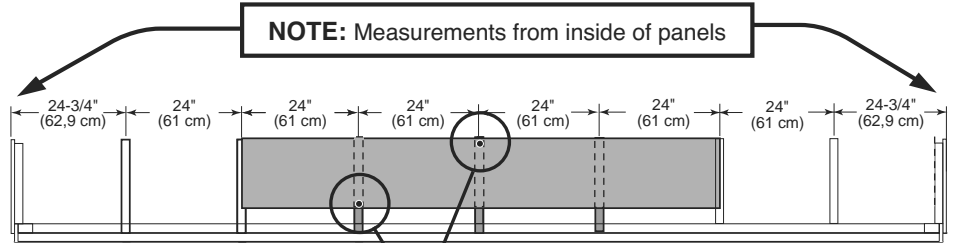
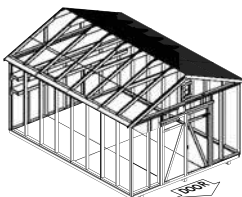
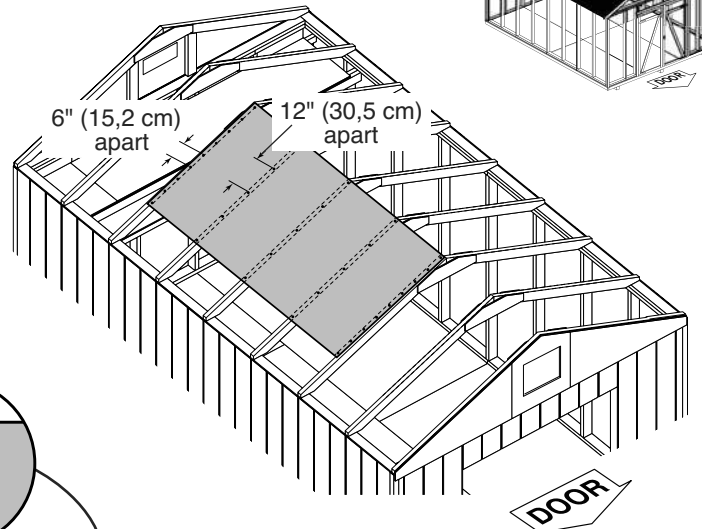
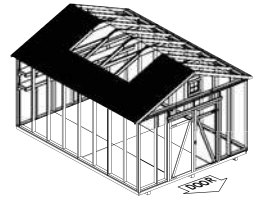

Fig. E

2" Nail
(5,1 cm)



GABLE 12' x 16'

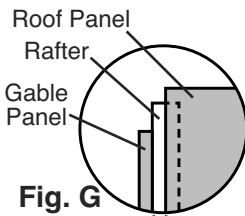

Fig. G

1/2" (1,3 cm)

6" (15,2 cm) apart

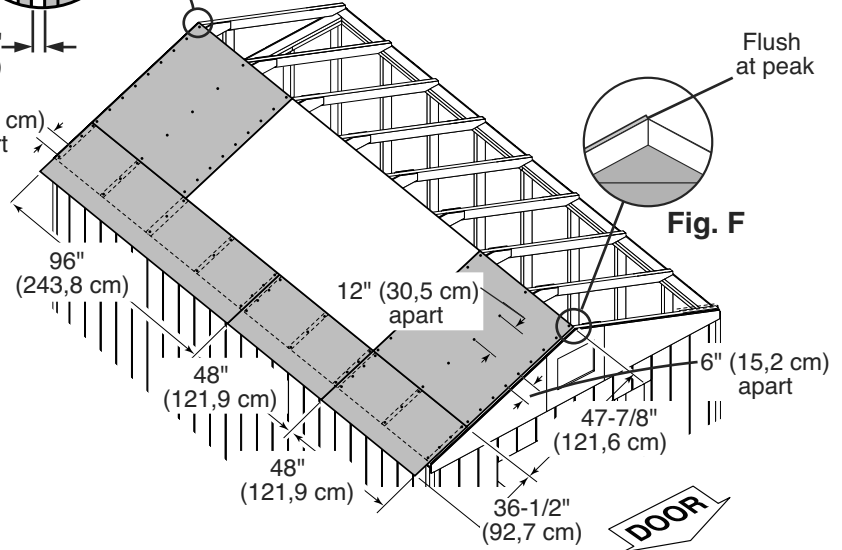

Fig. F

12' X 20' ROOF PANELS

PARTS REQUIRED:

x2



7/16 x 48 x 96"
(1,1 x 121,9 x 243,8 cm)

GAA
3/4"
GAUGE BLOCK

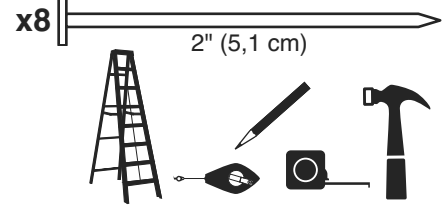

• FOR 12' x 24', SKIP TO PAGE 60

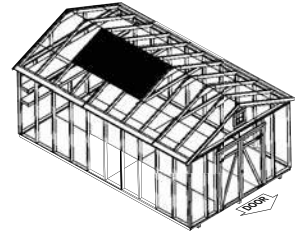

Roof panels may cause serious injury until securely fastened.



You must square the roof by attaching one panel first. You must use the panel's long edge as a lever to bring your roof into square. Commonly known as "racking".

✓ BEGIN

- 1 Attach panel with the rough side up (painted-grid lines side) with a 3/4" (1,9 cm) measurement on the rafter (Fig A) and the panel flush at the peak (Fig. B).

Secure panel with two 2" nails in the corners.

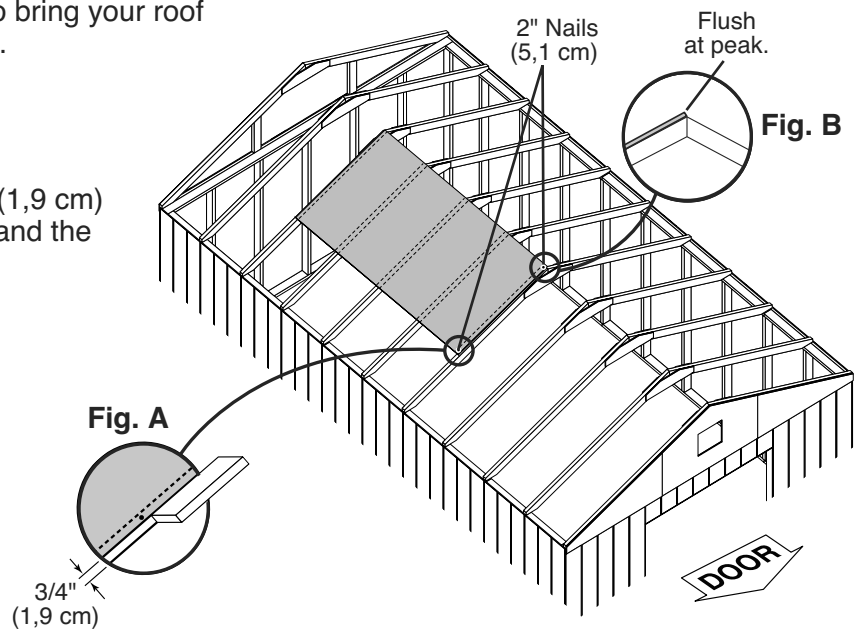

- 2 Move to the opposite end. Using the long edge of the panel as a lever move the panel side-to-side until the top corner is flush to the peak (Fig. C).



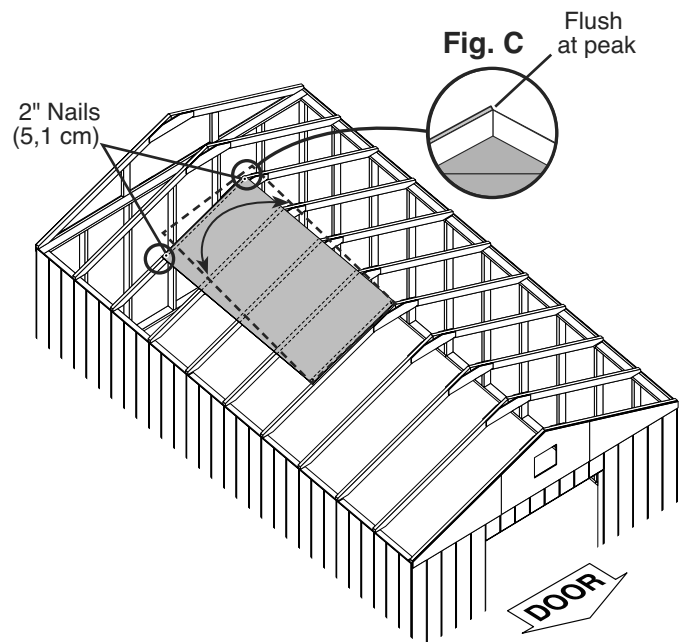

Secure panel with two 2" nails in the corners.



GABLE 12' x 20'

12' X 20' ROOF PANELS

PARTS REQUIRED:

x2		7/16 x 47-7/8 x 48" OSB (1,1 x 121,6 x 121,9 cm OSB)	x2		7/16 x 48 x 96" OSB (1,1 x 121,9 x 243,8 cm OSB)
x2		7/16 x 36-1/2 x 48" OSB (1,1 x 92,7 x 121,9 cm OSB)	x4		7/16 x 36-1/2 x 96" OSB (1,1 x 92,7 x 243,8 cm OSB)

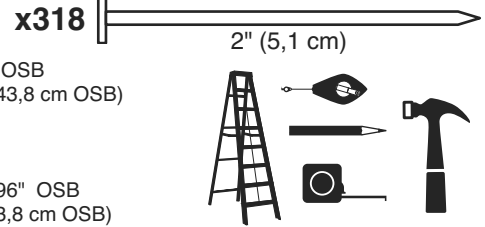

3 Keep spacing between the center of each rafter at the lower edge of the panel and secure with one 2" nail into each rafter (**Fig. E**).

Move to the top of the panel and keep spacing between the center of the rafters. Secure with one 2" nail into each rafter (**Fig. E**).

Nail the roof panel using 2" nails 6" apart on edges and 12" apart inside panel.

4 Attach the 47-7/8 x 48" and 48" x 96" roof panels flush to the upper panel and roof peak, with a 1/2" measurement at the rafter (**Fig. G**).

Nail the roof panel using 2" nails 6" apart on edges and 12" apart inside panel.

5 Attach the 36-1/2 x 96" lower roof panels flush (**Fig. F**) to the upper panels, with the 1/2" (1,3 cm) measurement at the rafter (**Fig. G**).

Nail the roof panels using 2" nails 6" apart on edges and 12" apart inside panel.

6 Attach the 36-1/2 x 48" lower roof panel flush to the upper panel, with the 1/2" (1,3 cm) measurement at the rafter (**Fig. G**).

Nail the roof panel using 2" nails 6" apart on edges and 12" apart inside panel.



7 Repeat process to attach roof panels on the opposite side.
Proceed to Page 62.

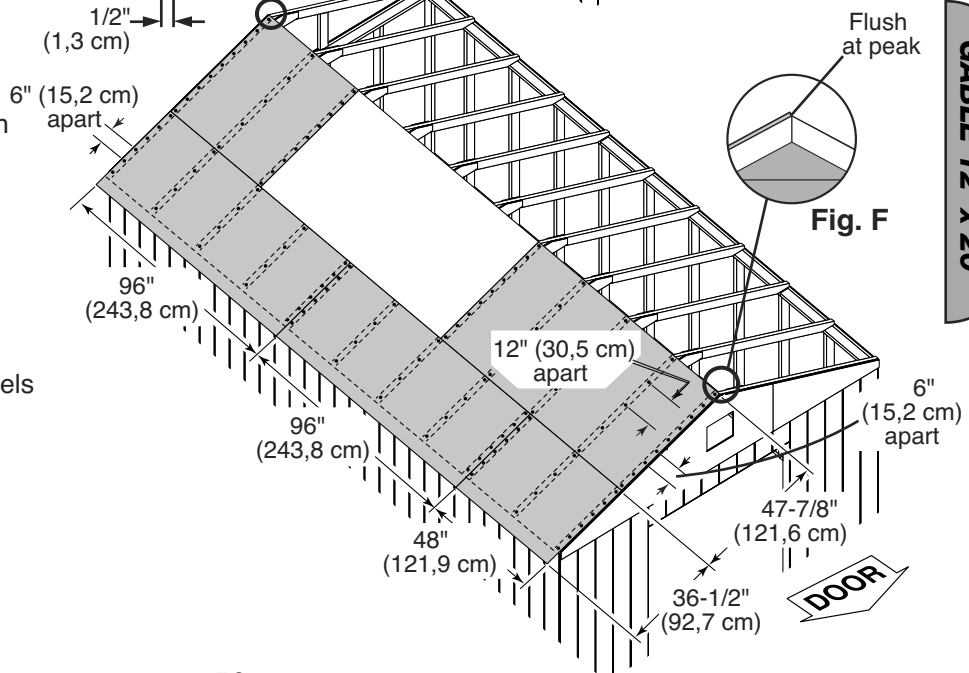
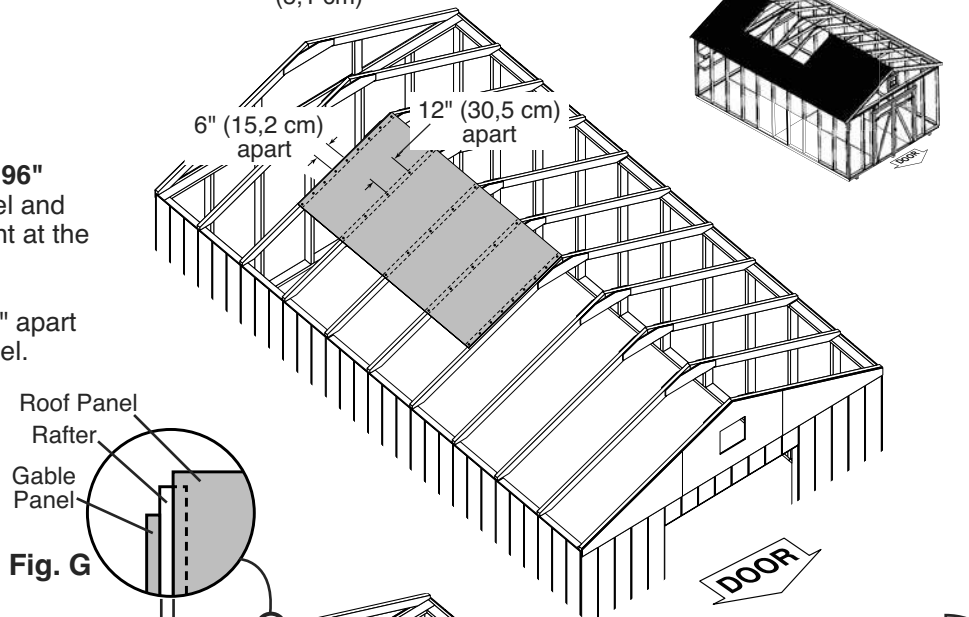
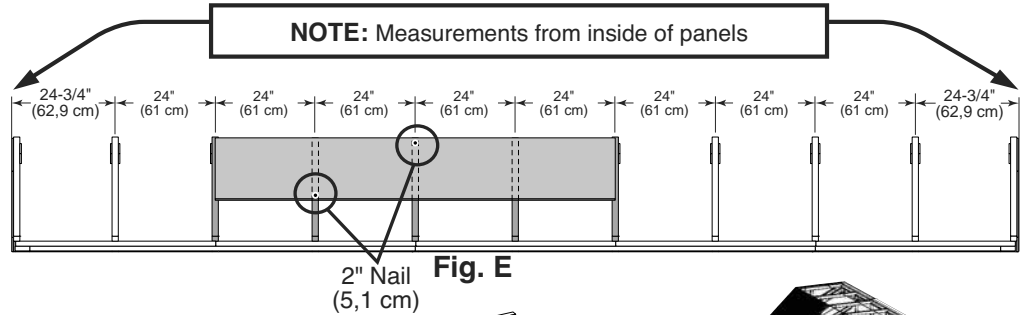
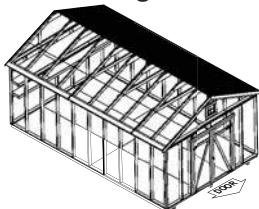

12' X 24' ROOF PANELS

PARTS REQUIRED:

x2



7/16 x 48 x 96"
(1,1 x 121,9 x 243,8 cm)

GAA
3/4"
GAUGE BLOCK

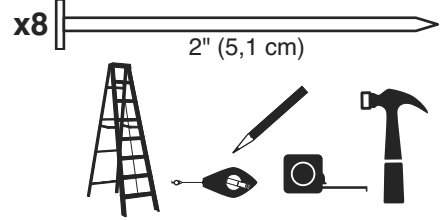

Roof panels may cause serious injury until securely fastened.

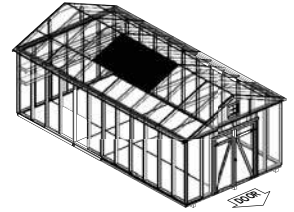

You must square the roof by attaching one panel first. You must use the panel's long edge as a lever to bring your roof into square. Commonly known as "racking".

✓ **BEGIN**

- 1 Attach panel with the rough side up (painted-grid lines side) with a 3/4" (1,9 cm) measurement on the rafter (**Fig A**) and the panel flush at the peak (**Fig. B**).

Secure panel with two 2" nails in the corners.

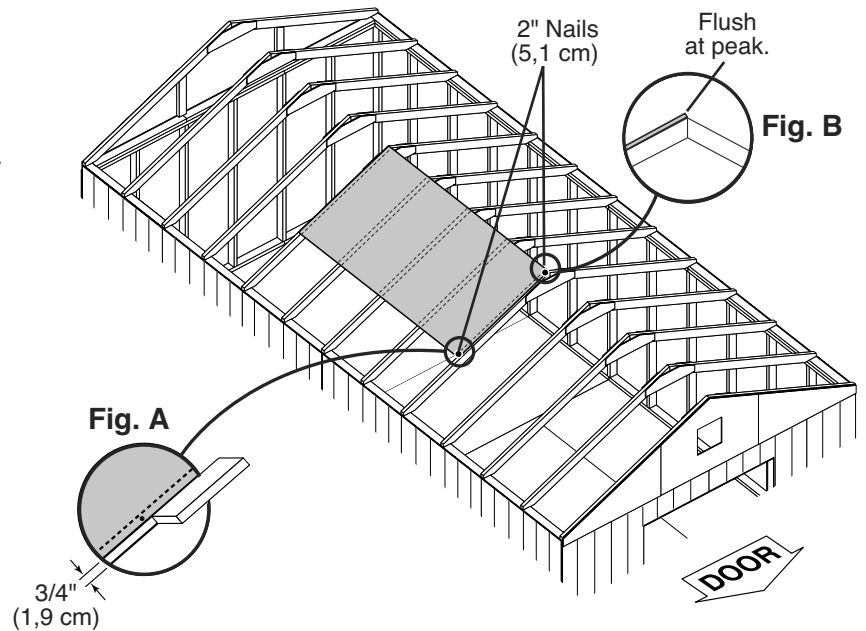



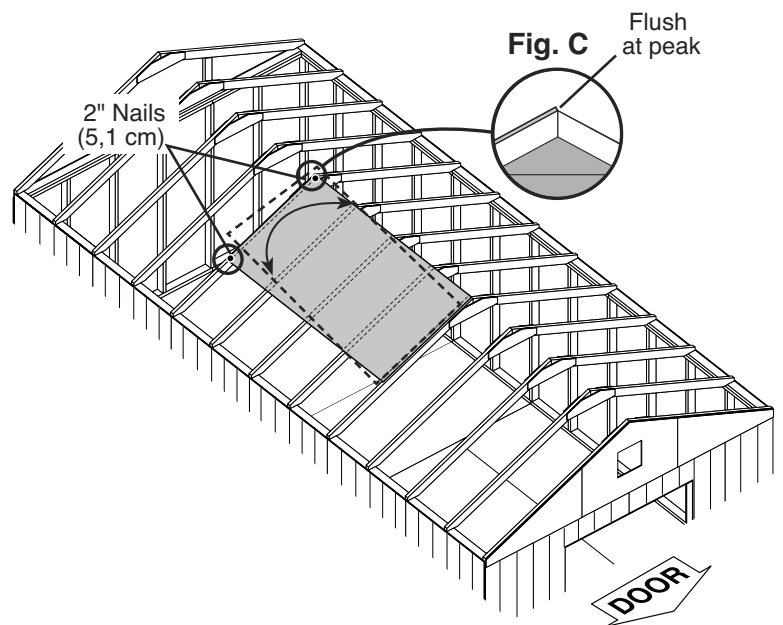

- 2 Move to the opposite end. Using the long edge of the panel as a lever move the panel side-to-side until the top corner is flush to the peak (**Fig. C**).

Secure panel with two 2" nails in the corners.

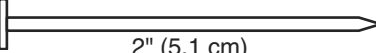
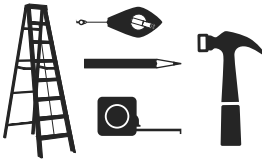

12' X 24' ROOF PANELS

PARTS REQUIRED:

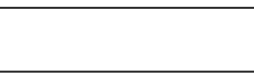
x4		7/16 x 47-7/8 x 48" OSB (1,1 x 121,6 x 121,9 cm OSB)	x2		7/16 x 48 x 96" OSB (1,1 x 121,9 x 243,8 cm OSB)	x358  2" (5,1 cm)	
x4		7/16 x 36-1/2 x 48" OSB (1,1 x 92,7 x 121,9 cm OSB)	x4		7/16 x 36-1/2 x 96" OSB (1,1 x 92,7 x 243,8 cm OSB)		

3 Keep spacing between the center of each rafter at the lower edge of the panel and secure with one 2" nail into each rafter (**Fig. E**).

Move to the top of the panel and keep spacing between the center of the rafters. Secure with one 2" nail into each rafter (**Fig. E**).

Nail the roof panel using 2" nails 6" apart on edges and 12" apart inside panel.

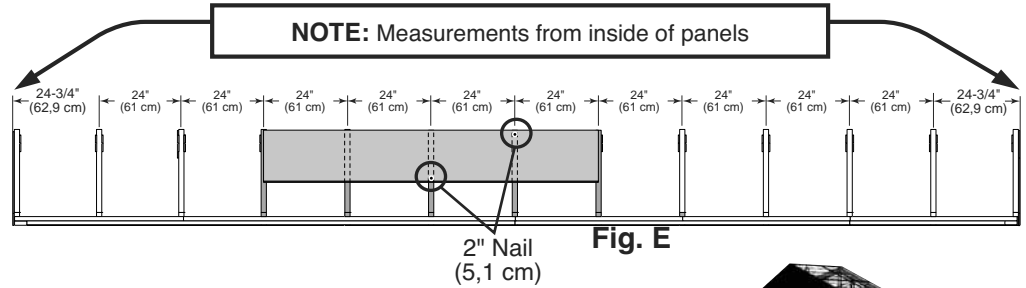

4 Attach the (2) 47-7/8 x 48" and 48 x 96" roof panels flush to the upper panel and roof peak, with a 1/2" measurement at the rafter (**Fig. G**).

Nail the roof panel using 2" nails 6" apart on edges and 12" apart inside panel.

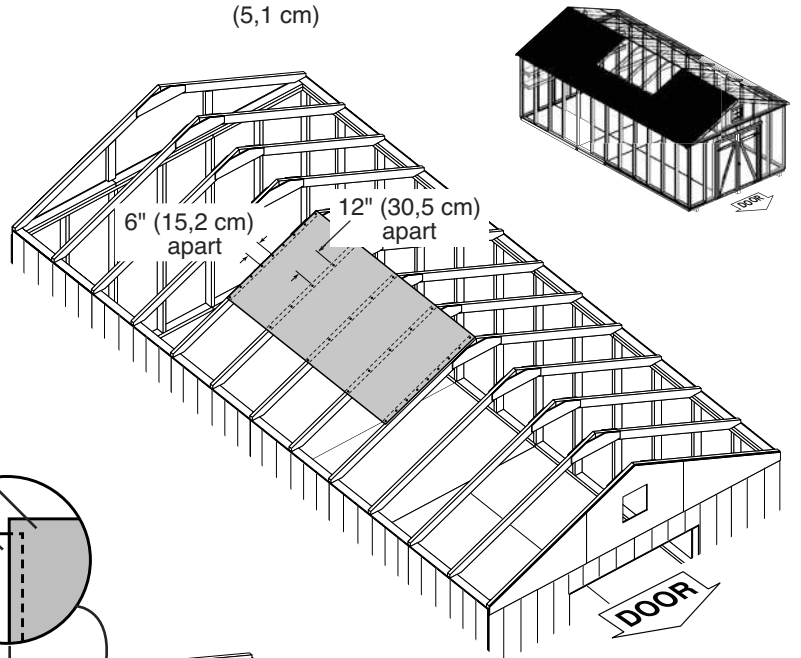

5 Attach the 36-1/2 x 96" lower roof panels flush (**Fig. F**) to the upper panels, with the 1/2" (1,3 cm) measurement at the rafter (**Fig. G**).

Nail the roof panels using 2" nails 6" apart on edges and 12" apart inside panel.

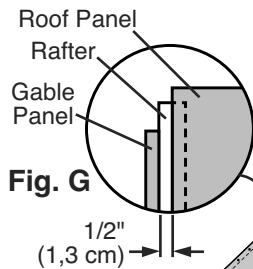

6 Attach the 36-1/2 x 48" lower roof panel flush to the upper panel, with the 1/2" (1,3 cm) measurement at the rafter (**Fig. G**).

Nail the roof panel using 2" nails 6" apart on edges and 12" apart inside panel.

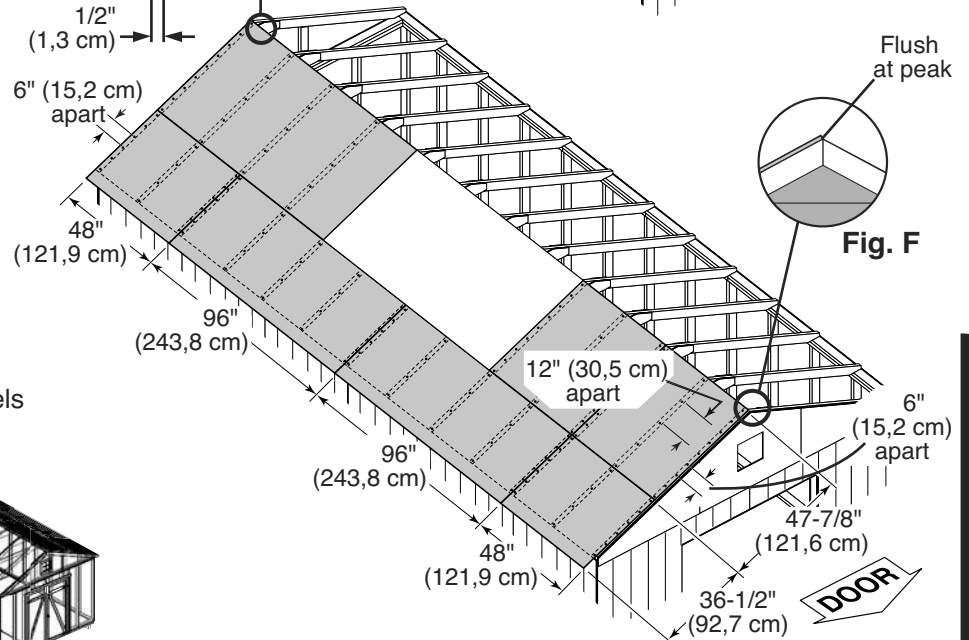

FINISH

7 Repeat process to attach roof panels on the opposite side. Proceed to Page 62.

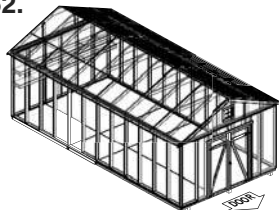

GABLE 12' X 24'

GABLE TRIM

PARTS REQUIRED:

- x2 **WYR**
19/32 x 4 x 85-3/16" (1,51 x 10,2 x 216,4 cm)
- x2 **WYL**
19/32 x 4 x 85-3/16" (1,51 x 10,2 x 216,4 cm)

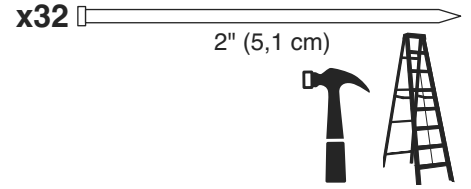

✓ **BEGIN**

- 1 Install front gable trim **WYR** and **WYL** flush to top of panel and flush at peak (**Fig. A**) as shown.
 - 2 Secure to wall using finish nails 7-1/4" apart.
 - 3 Repeat above steps to secure the back wall gable trim.
- FINISH
- 4 You have finished installing your gable trim.

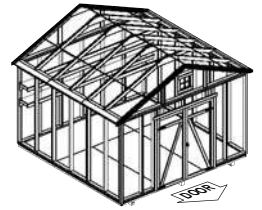

GABLE 12' x 12'

GABLE 12' x 16'

GABLE 12' x 20'

GABLE 12' x 24'

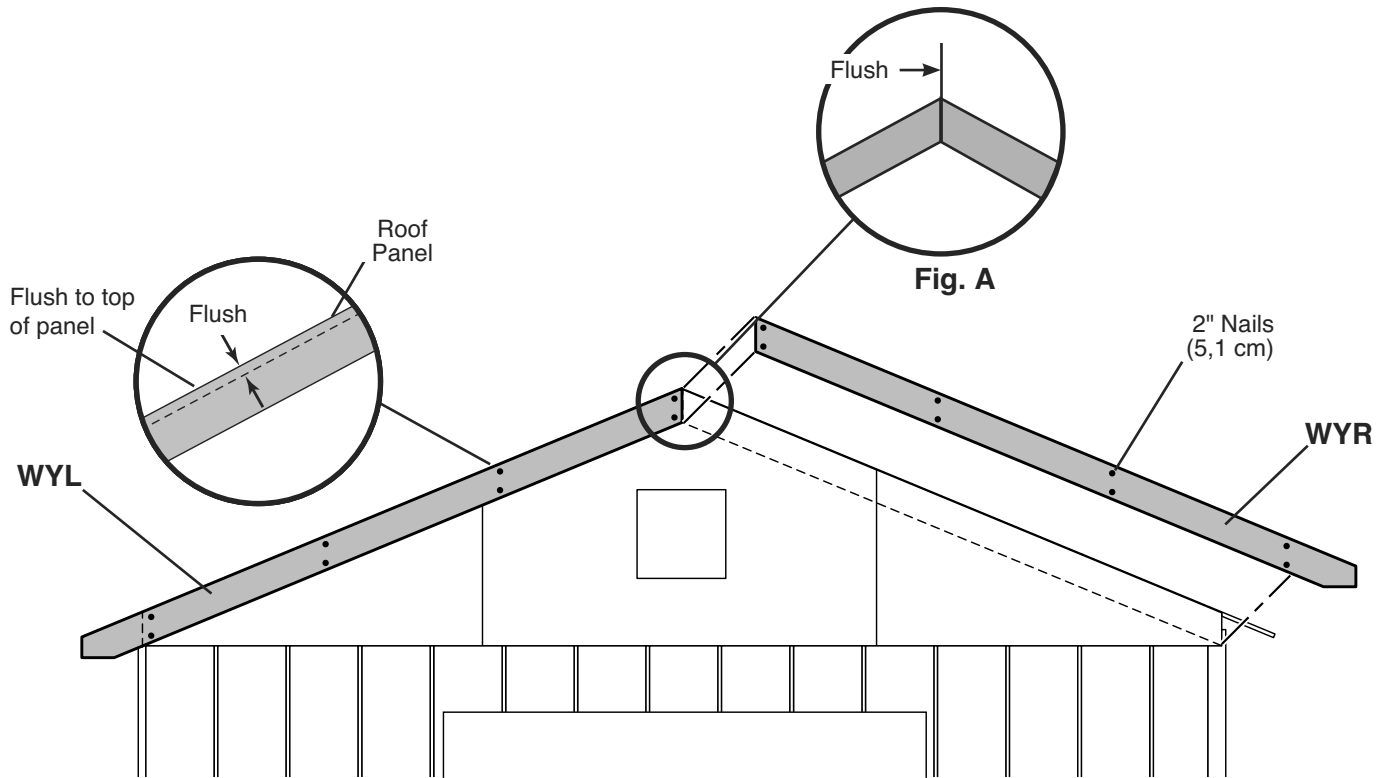

NOTE: 12' x 12' Model Shown.

12' x 12' EAVE TRIM

PARTS REQUIRED:

x2 **AS**
2 x 6 x 49-1/2" (5,1 x 15,2 x 125,7 cm)

x2 **VX**
2 x 6 x 96" (5,1 x 15,2 x 243,8 cm)

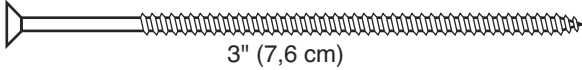
x8  3" (7,6 cm)

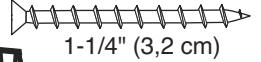
x60  1-1/4" (3,2 cm)

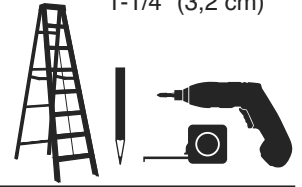

- FOR 12' x 16', SKIP TO PAGE 64
- FOR 12' x 20', SKIP TO PAGE 65
- FOR 12' x 24', SKIP TO PAGE 66

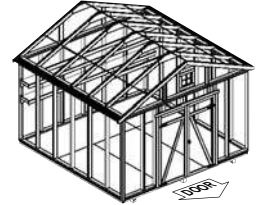

GABLE 12' x 12'

✓ BEGIN

- 1 Orient **AS** between gable trim flush to edge of roof panel (Fig. A). 
- 2 Screw through roof panel into eave side overhang using 1-1/4" screws approximately 7-1/2" apart as shown.
- 3 Orient **VX** between **AS** and gable trim, flush to edge of roof panel.
- 4 Secure **VX** and **AS** with two 3" screws through gable trim at each end.

FINISH

- 5 Repeat process on opposite side. You have finished your eave trim.

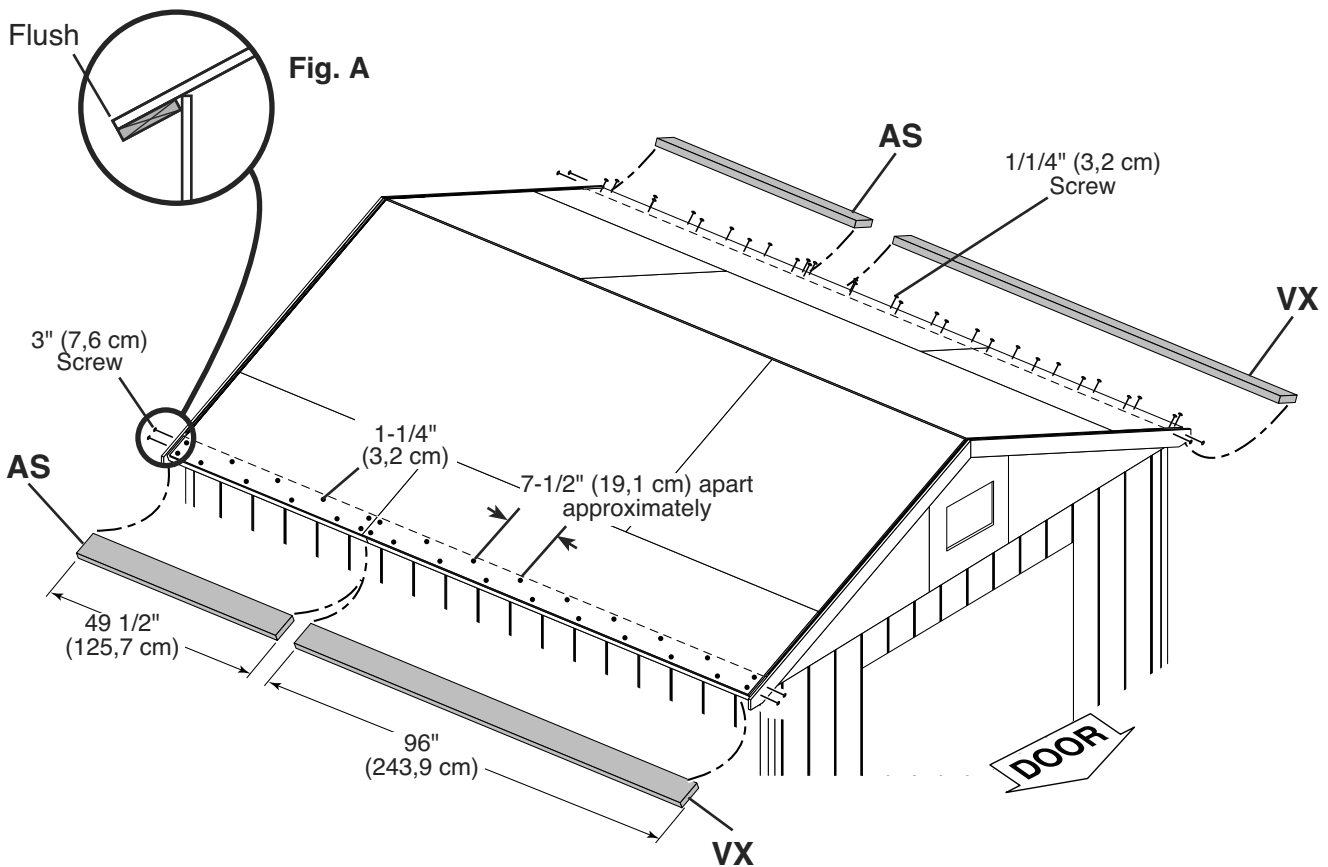

12' x 16' EAVE TRIM

PARTS REQUIRED:

x2 **AS**

2 x 6 x 49-1/2" (5,1 x 15,2 x 125,7 cm)

x2 **VF**

2 x 6 x 48" (5,1 x 15,2 x 121,9 cm)

x2 **VX**

2 x 6 x 96" (5,1 x 15,2 x 243,8 cm)

x8

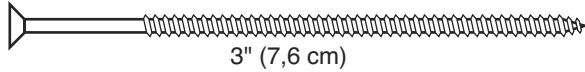

3" (7,6 cm)

x88

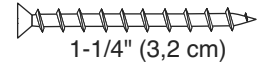

1-1/4" (3,2 cm)

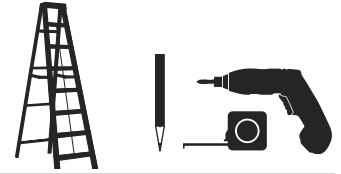

• FOR 12' x 20', SKIP TO PAGE 65

• FOR 12' x 24', SKIP TO PAGE 66

✓ BEGIN

- 1 Orient **VF** flush with gable trim and flush to edge of roof panel (Fig. A).
- 2 Screw through roof panel into eave side overhang using 1-1/4" screws approximately 7-1/2" apart as shown.
- 3 Orient **VX** flush with gable trim and flush to edge of roof panel. Repeat step 2 to attach **VX**.
- 4 Orient **AS** between **VF** and **VX** flush to edge of roof panel. Repeat step 2 to attach **AS**.
- 5 Secure **VF** and **VX** with two 3" screws through gable trim at each end.

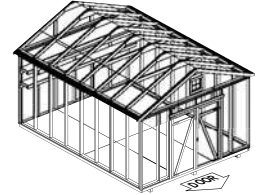

FINISH

- 6 Repeat process on opposite side. You have finished your eave trim.

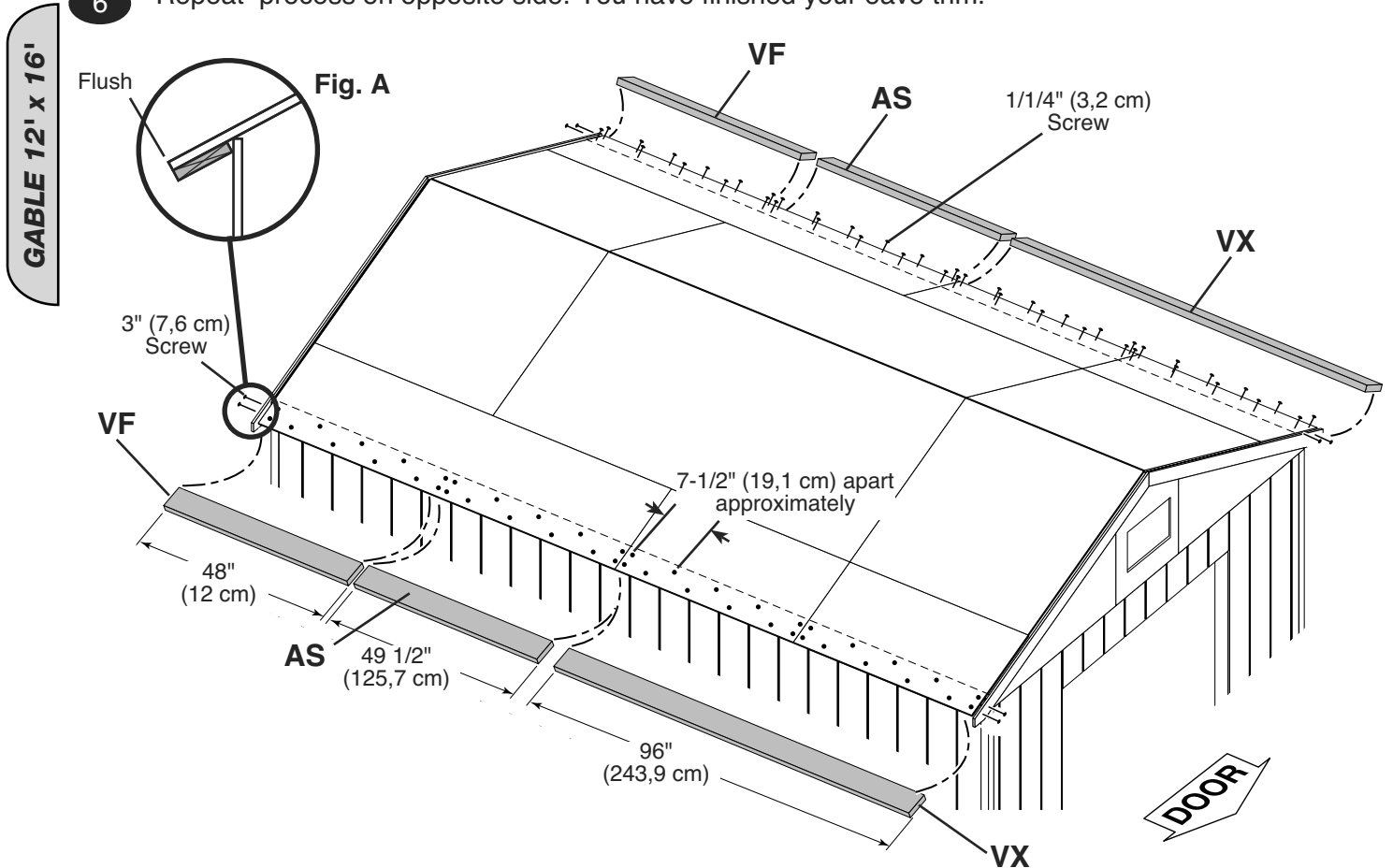

12' x 20' EAVE TRIM

PARTS REQUIRED:

x2 **AS**

2 x 6 x 49-1/2" (5,1 x 15,2 x 125,7 cm)

x4 **VX**

2 x 6 x 96" (5,1 x 15,2 x 243,8 cm)

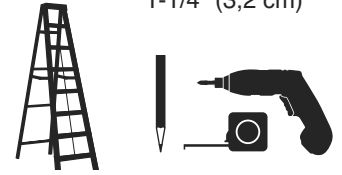
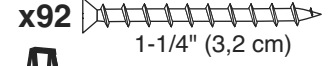
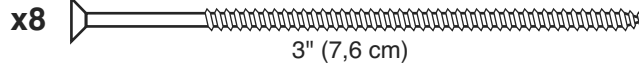

✓ BEGIN



• FOR 12' x 24', SKIP TO PAGE 66

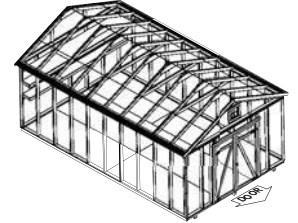

- 1 Orient **VX** flush with gable trim and flush to edge of roof panel (Fig. A).
- 2 Screw through roof panel into eave side overhang using 1-1/4" screws approximately 7-1/2" apart as shown.
- 3 Orient **AS** flush with gable trim and flush to edge of roof panel. Repeat step 2 to attach **AS**.
- 4 Orient **VX** between **AS** and **VX** flush to edge of roof panel. Repeat step 2 to attach **VX**.
- 5 Secure **VX** and **AS** with two 3" screws through gable trim at each end.

FINISH

- 6 Repeat process on opposite side. You have finished your eave trim.

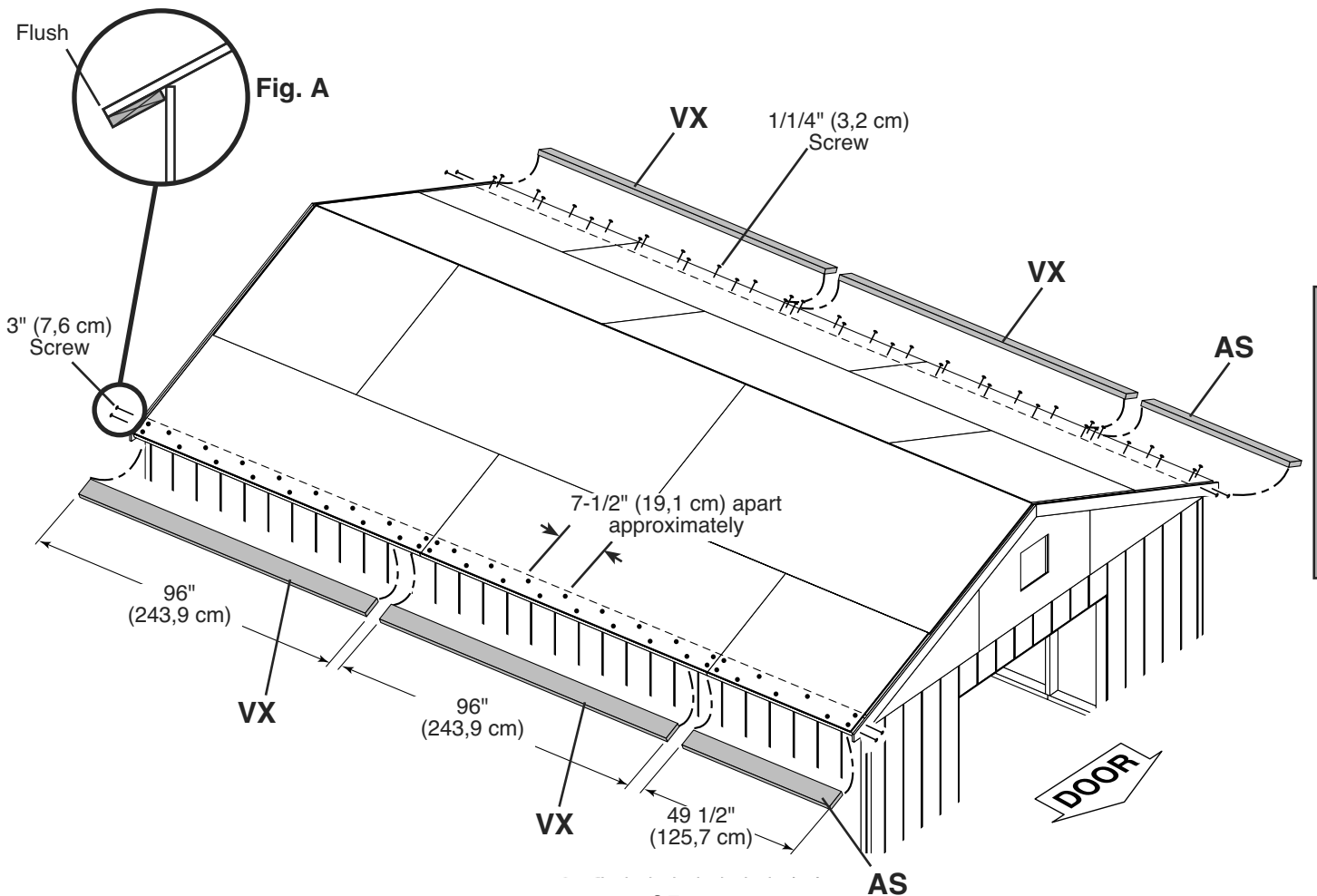

GABLE 12' x 20'

12' x 24' EAVE TRIM

PARTS REQUIRED:

x2 **AS**
2 x 6 x 49-1/2" (5,1 x 15,2 x 125,7 cm)

x2 **VF**
2 x 6 x 48" (5,1 x 15,2 x 121,9 cm)

x4 **VX**
2 x 6 x 96" (5,1 x 15,2 x 243,8 cm)

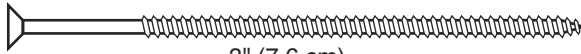
x8  3" (7,6 cm)

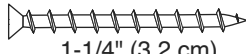
x103  1-1/4" (3,2 cm)

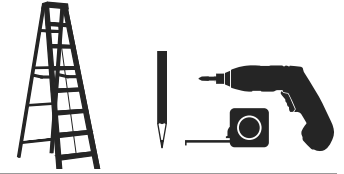

✓ BEGIN

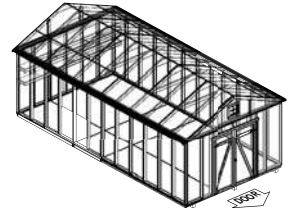

- 1 Orient **VX** flush with gable trim and flush to edge of roof panel (**Fig. A**).
- 2 Screw through roof panel into eave side overhang using 1-1/4" screws approximately 7-1/2" apart as shown.
- 3 Orient **AS** flush with gable trim and flush to edge of roof panel. Repeat step 2 to attach **AS**.
- 4 Orient **VF** and **VX** between **AS** and **VX** flush to edge of roof panel. Repeat step 2 to attach **VF** and **VX**.
- 5 Secure **VX** and **AS** with two 3" screws through gable trim at each end.

FINISH

- 6 Repeat process on opposite side. You have finished your eave trim.

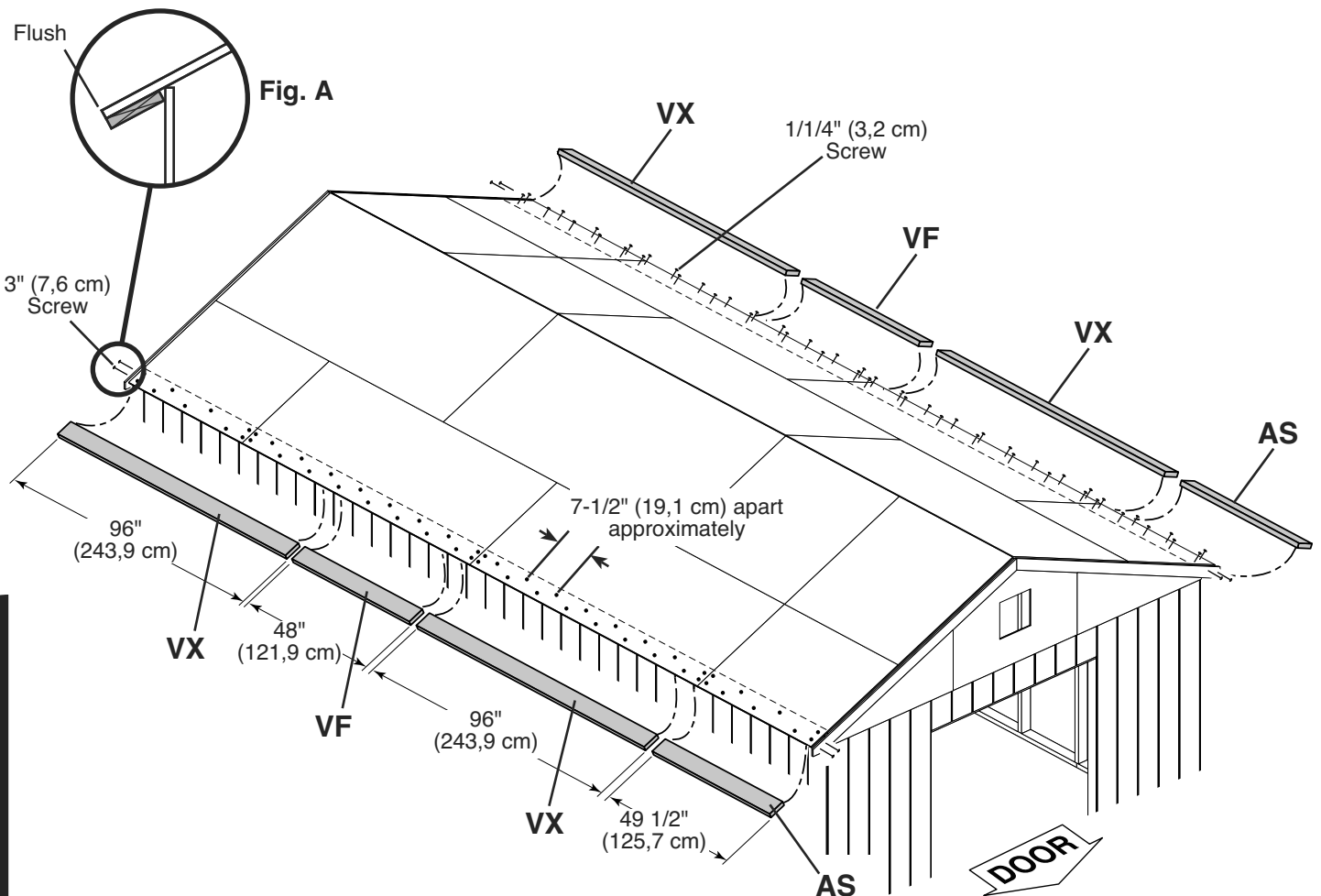

GABLE 12' x 24'

CORNER TRIM

PARTS REQUIRED:

x4 
1-3/4 x 81-1/2 x 3/8" (4,4 x 207 x 1 cm)

x4 
1-3/4 x 83-1/2 x 3/8" (4,4 x 212,1 x 1 cm)

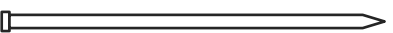
x64 
2" (5,1 cm)

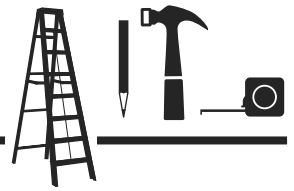

✓ BEGIN

- 1 Secure 83-1/2" (212,1 cm) corner trim under side eave trim. Attach with 2" nails as shown in (Fig. A).
- 2 Secure 81-1/2" (207 cm) corner trim flush under gable panel. Attach with finish nails as shown.
- 3 Repeat on other side.

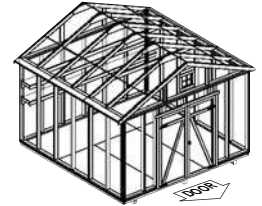

FINISH

- 4 Proceed to installing your collar ties.

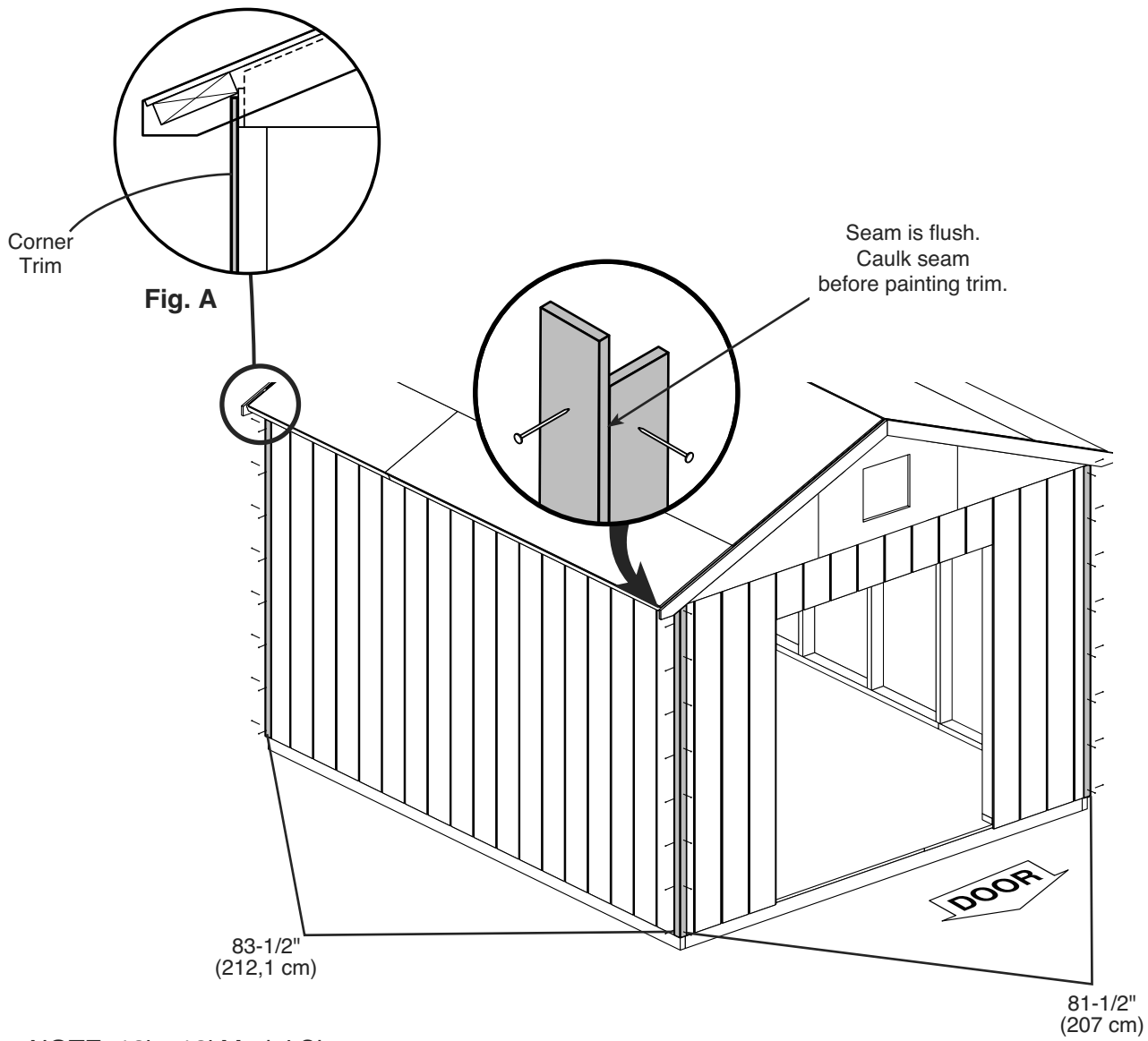

GABLE 12' x 12'

GABLE 12' x 16'

GABLE 12' x 20'

GABLE 12' x 24'

NOTE: 12' x 12' Model Shown.

12' x 12' COLLAR TIE

PARTS REQUIRED:

x1 **TP**
2 x 4 x 96" (5,1 x 10,2 x 243,9 cm)

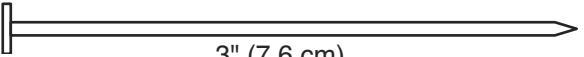
x6  3" (7,6 cm)

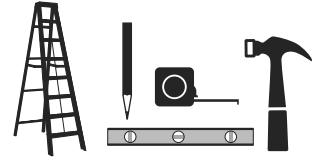

- FOR 12' x 16', SKIP TO PAGE 69
- FOR 12' x 20', SKIP TO PAGE 70
- FOR 12' x 24', SKIP TO PAGE 71

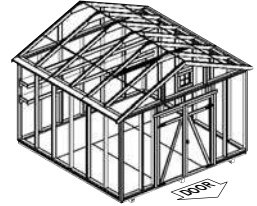

GABLE 12' x 12'

✓ **BEGIN**

1 Locate collar tie **TP** on back of center rafter as shown. 
Check collar tie is level and flush to roof panel.

2 Nail collar tie to the 3rd rafter from the front with three 3" nails at each end.

 **FINISH**

3 You have finished installing your collar tie.

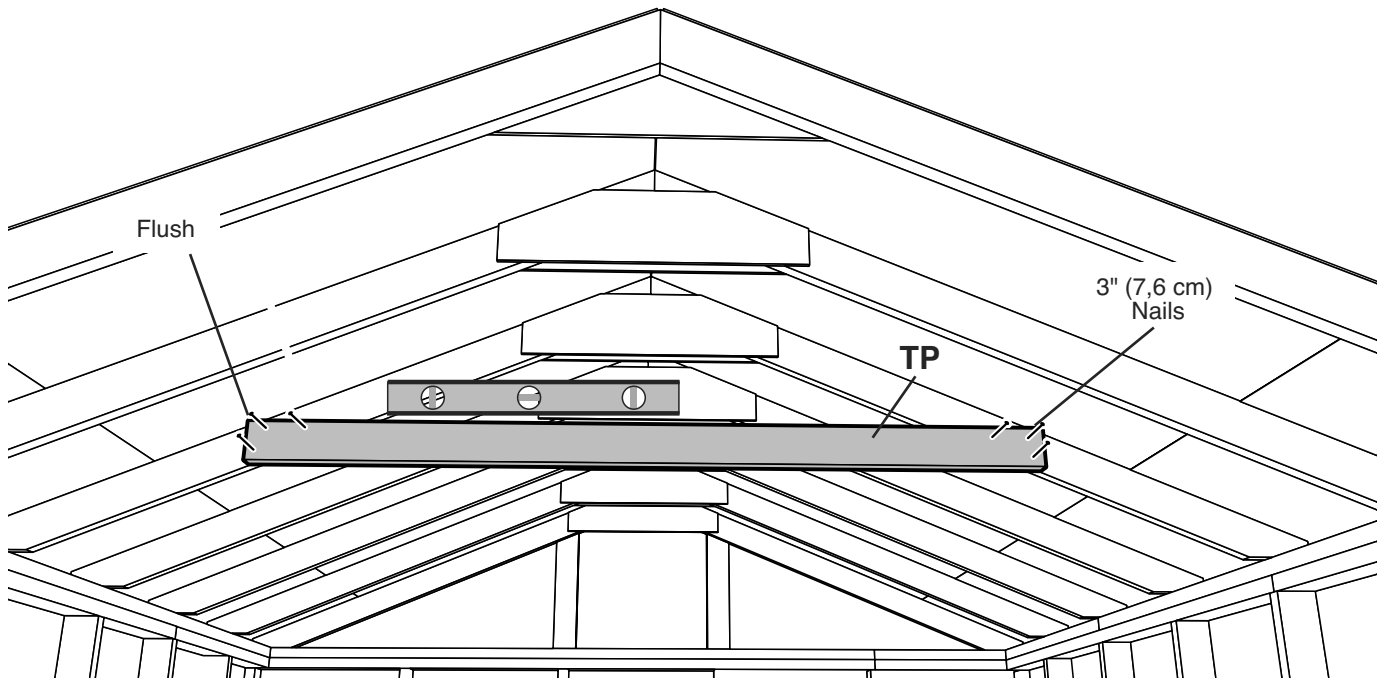

HINT: For best appearance, install collar tie on back side of rafter.

12' x 16' COLLAR TIES

PARTS REQUIRED:

x2 **TP**
2 x 4 x 96" (5,1 x 10,2 x 243,9 cm)

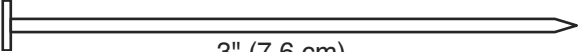
x12  3" (7,6 cm)

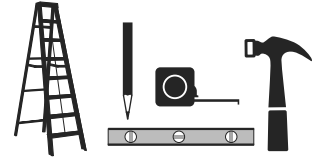

- FOR 12' x 20', SKIP TO PAGE 70
- FOR 12' x 24', SKIP TO PAGE 71

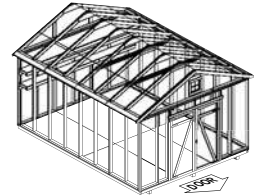

✓ BEGIN

- 1 Locate collar tie **TP** on back of 3rd rafter from the door as shown.
Check collar tie is level and flush to roof panel.
- 2 Nail collar tie to rafter with three 3" nails at each end.
- 3 Repeat steps 1-2 to attach second collar tie to the fifth rafter from the door.



FINISH

- 4 You have finished installing your collar ties.

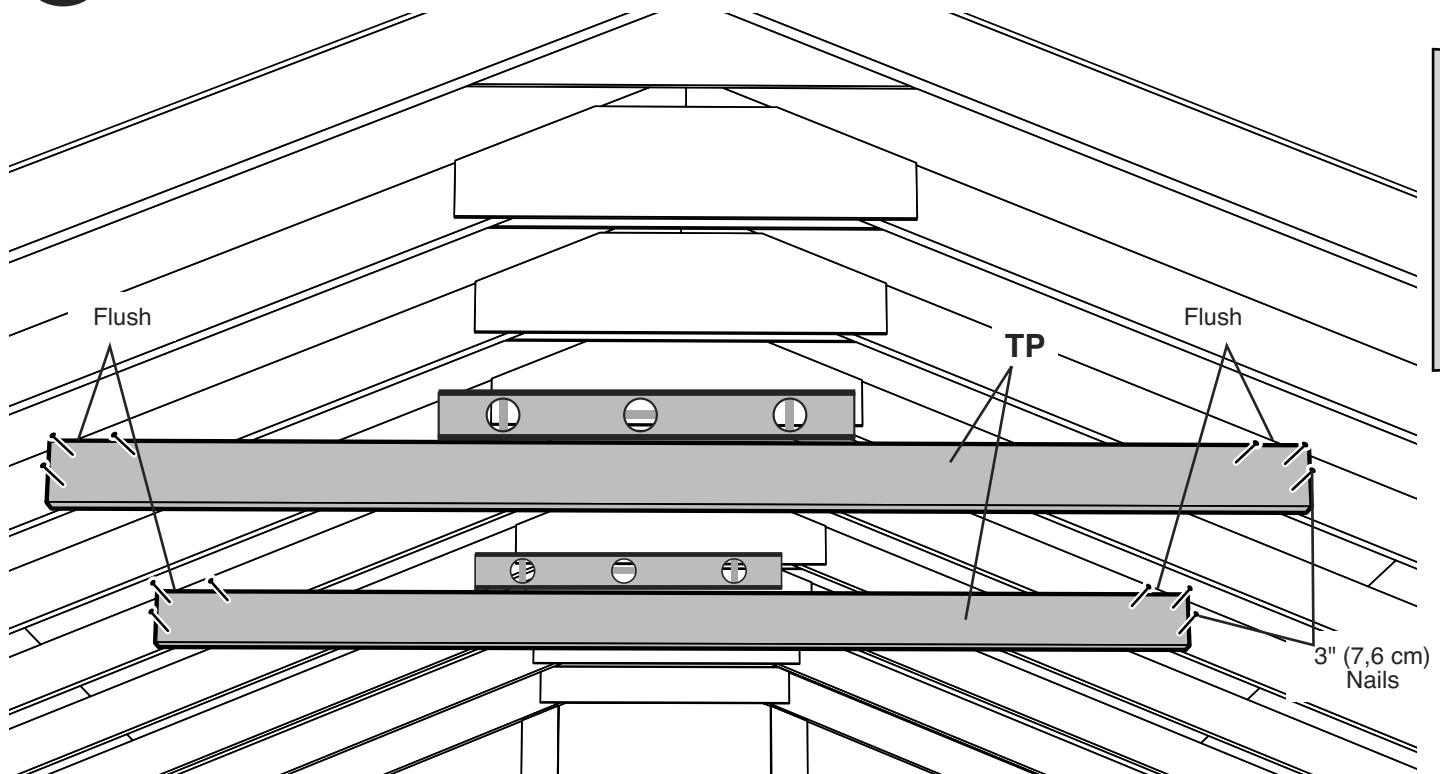

HINT: For best appearance, install collar tie on back side of rafter.

12' x 20' COLLAR TIES

PARTS REQUIRED:

x3 **TP**
2 x 4 x 96" (5,1 x 10,2 x 243,9 cm)

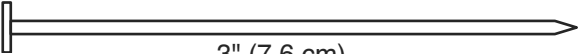
x18  3" (7,6 cm)

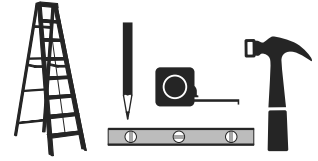

• FOR 12' x 24', SKIP TO PAGE 71

✓ BEGIN

1 Locate collar tie **TP** on back of 3rd rafter from the door as shown.
Check collar tie is level and flush to roof panel.

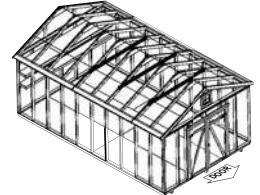

2 Nail collar tie to rafter with three 3" nails at each end.

3 Repeat steps 1-2 to attach collar ties to the fifth and seventh rafter from the door.



FINISH

4 You have finished installing your collar ties.

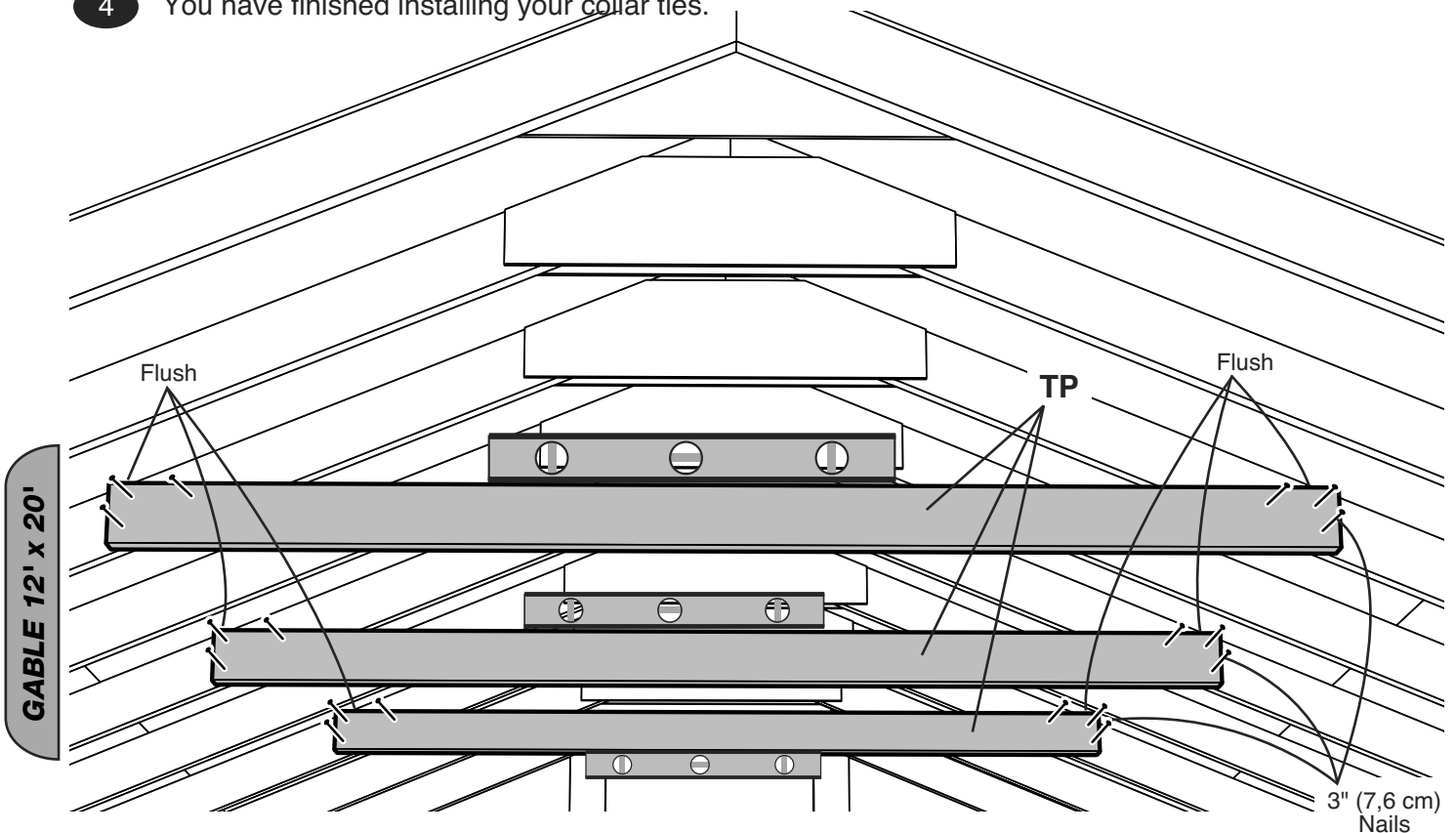

HINT: For best appearance, install collar tie on back side of rafter.

12' x 24' COLLAR TIES

PARTS REQUIRED:

x4 TP
2 x 4 x 96" (5,1 x 10,2 x 243,9 cm)

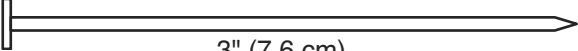
x24  3" (7,6 cm)

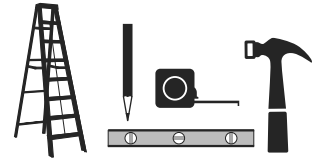

✓ BEGIN

1 Locate collar tie **TP** on back of 3rd rafter from the door as shown.
Check collar tie is level and flush to roof panel.

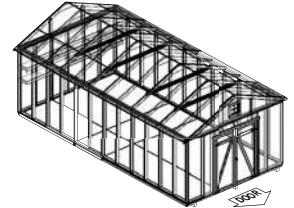

2 Nail collar tie to rafter with three 3" nails at each end.

3 Repeat steps 1-2 to attach collar ties to the fifth, eighth and tenth rafter from the door.

FINISH

4 You have finished installing your collar ties.

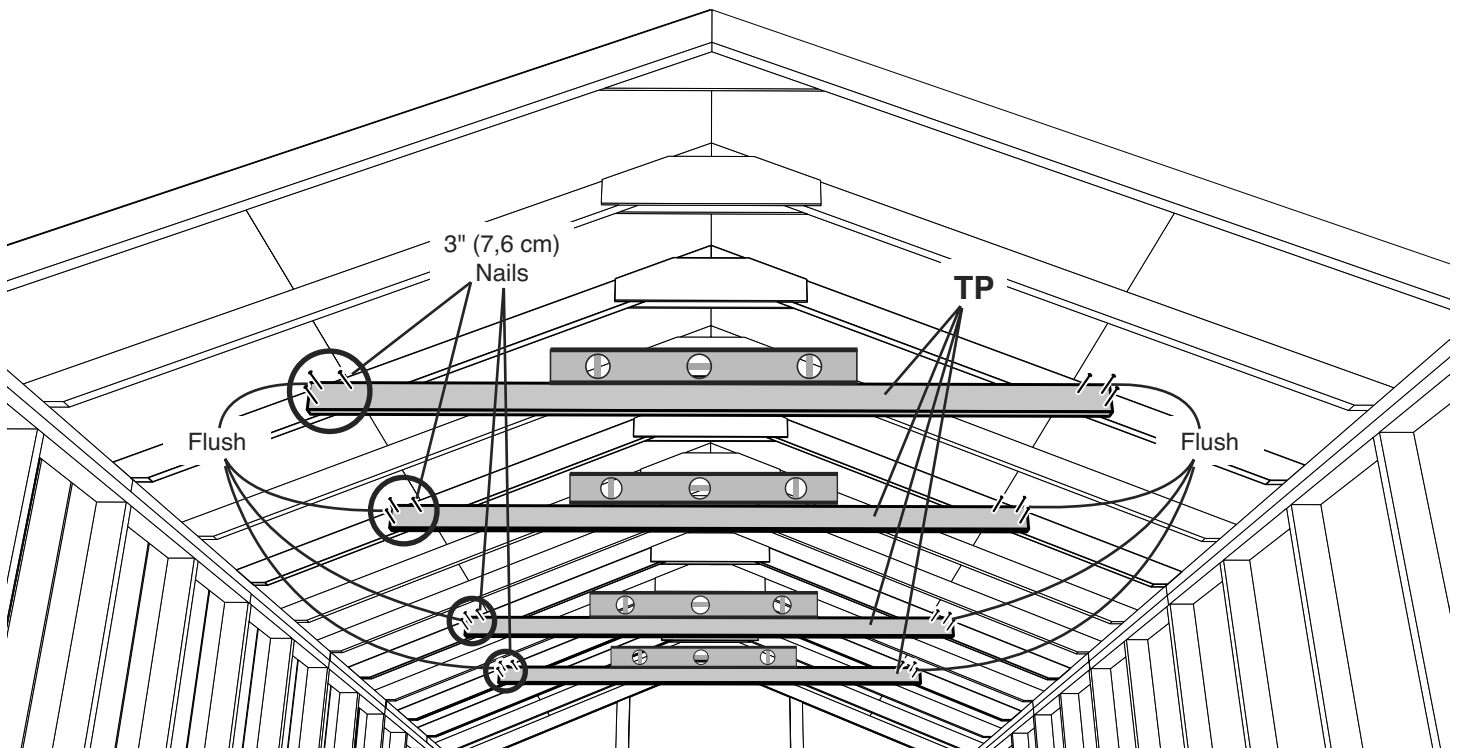

HINT: For best appearance, install collar tie on back side of rafter.

LOFT JOIST ASSEMBLY

PARTS REQUIRED:

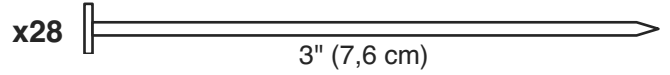

x2 **TP**
2 x 4 x 96" (5,1 x 10,2 x 243,8 cm)

x2 **SP**
2 x 4 x 48" (5,1 x 10,2 x 122 cm)



✓ BEGIN

- 1 Ensure parts **TP** and **SP** are aligned perfectly on a flat surface. Spread glue across **SP** and **TP** as shown.
- 2 Assemble joist with 3" (7,6 cm) nails in a staggered pattern.
- 3 Turn assembled joist over and repeat staggered nail pattern.
- 4 Support and drill a 7/16" (1,1 cm) hole through each end of each joist (**Fig A**).

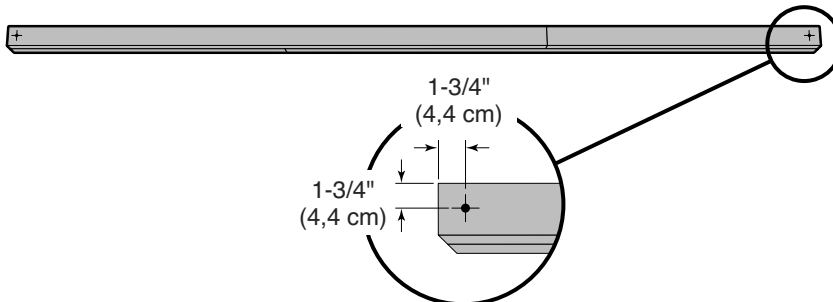
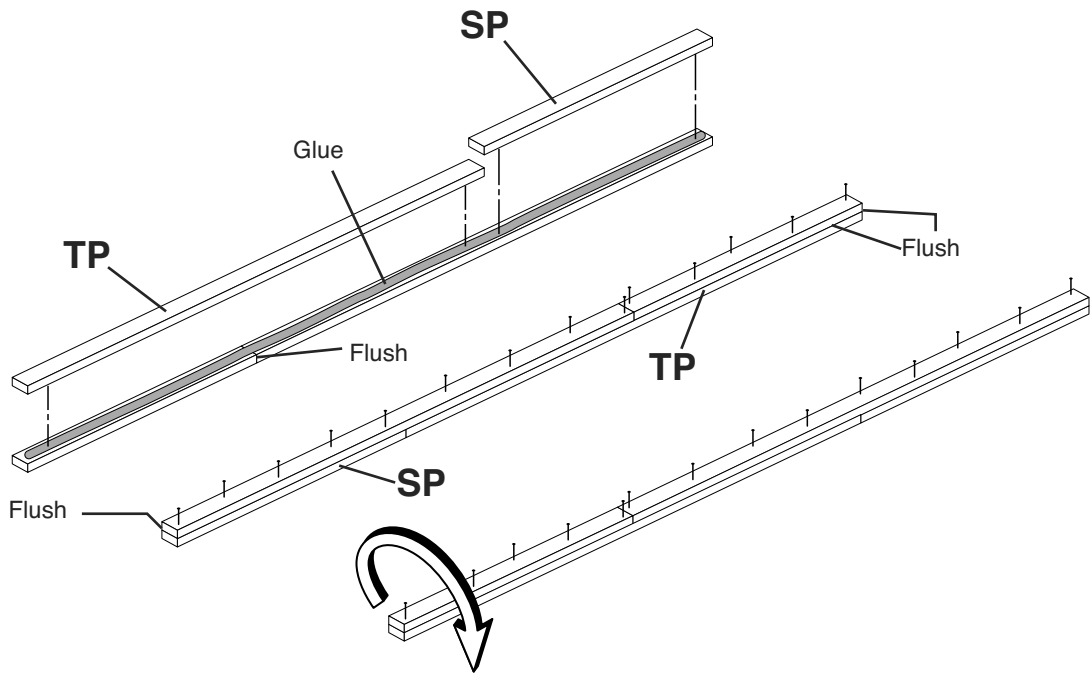
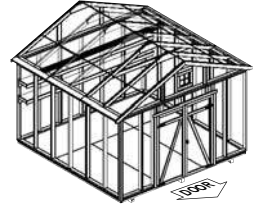

Fig. A

GABLE 12' x 12'

GABLE 12' x 16'

GABLE 12' x 20'

GABLE 12' x 24'

LOFT JOIST INSTALLATION

PARTS REQUIRED:

x1 **PT**
2 x 3 x 96" (5,1 x 7,6 x 243,8 cm)

x1 **ZJ**
2 x 3 x 48" (5,1 x 7,6 x 122 cm)

x1 **LOFT JOIST ASSEMBLY**

x16 3" (7,6 cm)

x2 5-1/2" (14 cm) Hexbolt, 2 washers and locknut

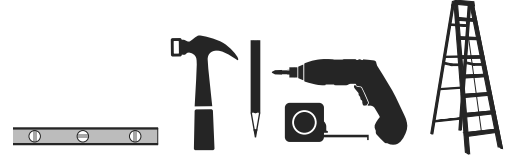

✓ BEGIN

- 1 Measure, mark and locate **ZJ** and **PT** flush to bottom of top plate and secure with 3" (7,6 cm) nails at each backwall stud.
- 2 Measure, mark and locate joist assembly flush to bottom of top plate and against wall studs 24" (61 cm) from back wall.
- 3 Clamp or hold joist assembly level against wall studs. Drill through joist with 7/16" (1,1 cm) drill bit.
- 4 Secure joist assembly with 5-1/2" (14 cm) Hexbolt, flat washers and lock nut (**Fig. A**).

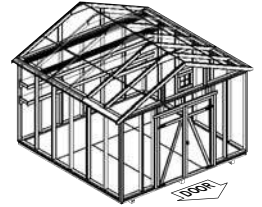

GABLE 12' x 12'

GABLE 12' x 16'

GABLE 12' x 20'

GABLE 12' x 24'

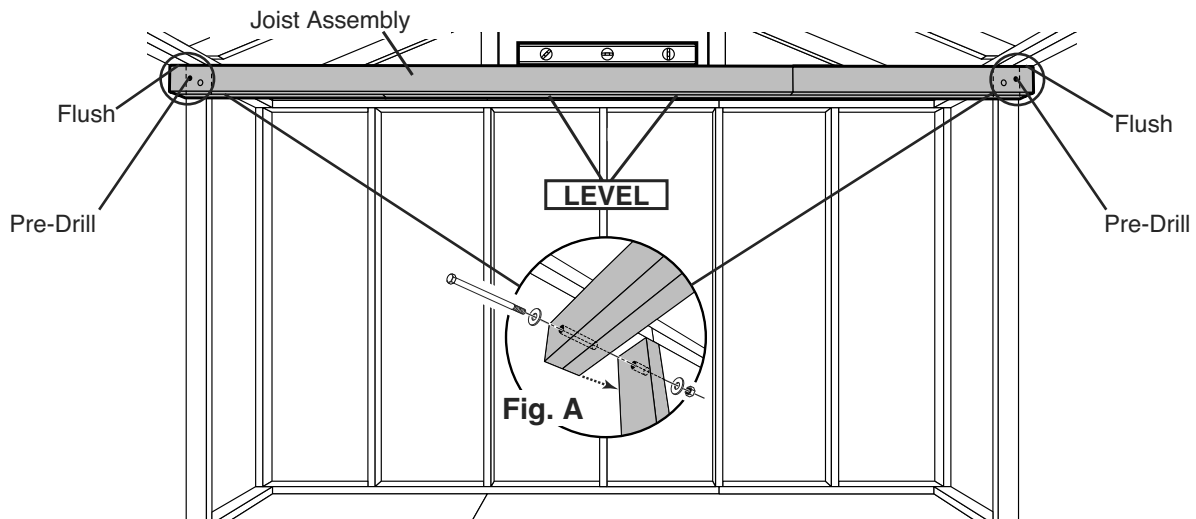
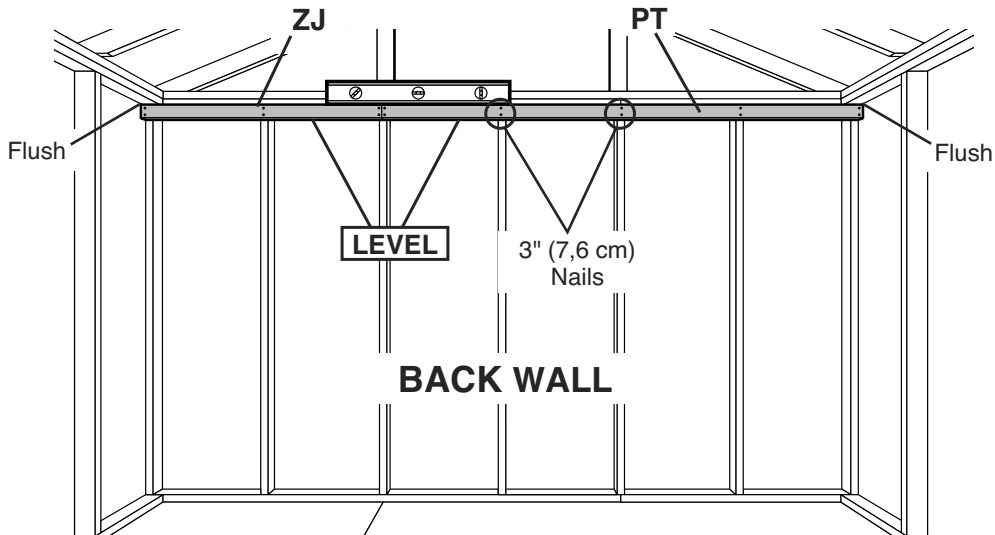

LOFT PANELS

PARTS REQUIRED:

x1

 23-7/8" x 40-7/8" (60,1 x 104 cm)

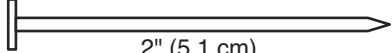
x1

 23-7/8" x 96" (60,1 x 244 cm)

x34  2" (5,1 cm)



GABLE 12' x 12'

✓ **BEGIN**

1 Install loft panels centered over loft joists and ledger board. Secure with 2" (5,1 cm) nails 8" (20,3 cm) apart.

NOTE: There will be a gap of approximately 1/2" on either side of installed deck panels.

 **FINISH**

2 You have finished installing your Loft.

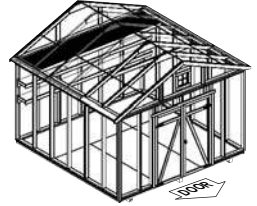

GABLE 12' x 16'

GABLE 12' x 20'

GABLE 12' x 24'

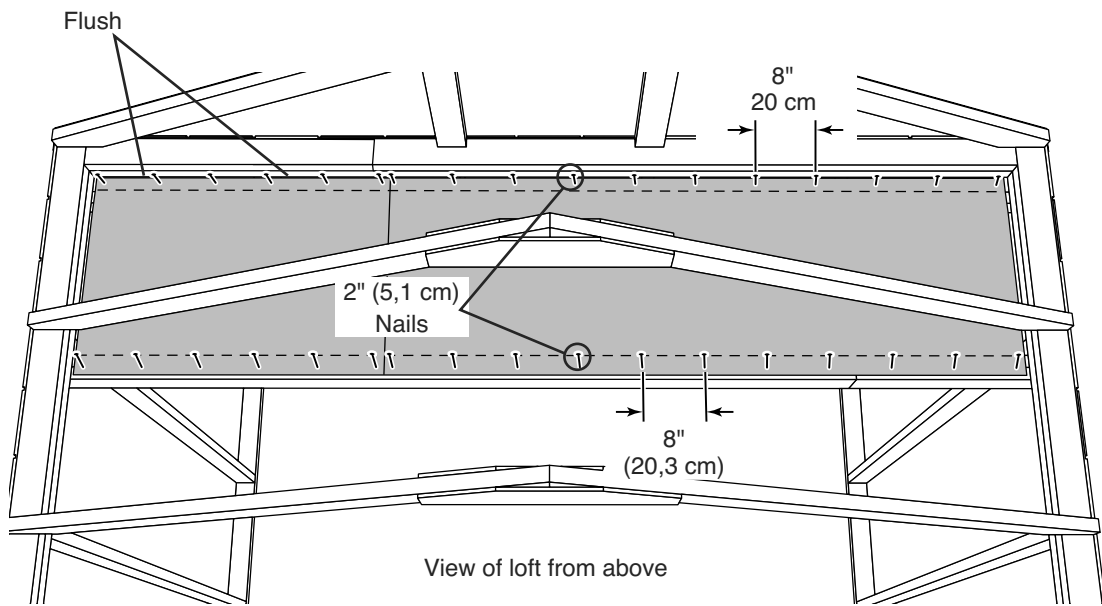



View of loft from above

Attention:
 Load not to exceed
 400 lbs (181 kg) evenly
 distributed across loft.

SHELF INSTALLATION

PARTS REQUIRED:

x14 
 3/8 x 8 x 12-1/2" (1 x 20,3 x 31,8 cm)

x14 **AC** 
 2 x 3 x 10" (5,1 x 7,6 x 25,4 cm)

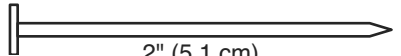
x84 
 2" (5,1 cm)

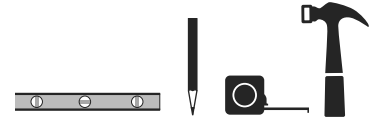

✓ BEGIN

1 Secure **AC** to shelf panels using three 2" (5,1 cm) nails. Assemble 12 shelf supports as shown; 2 right-side, 12 left-side.

2 Secure shelf supports at shown heights with three 2" (5,1 cm) nails.

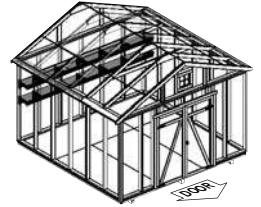

FINISH

3 Continue shelf installation on page 66.

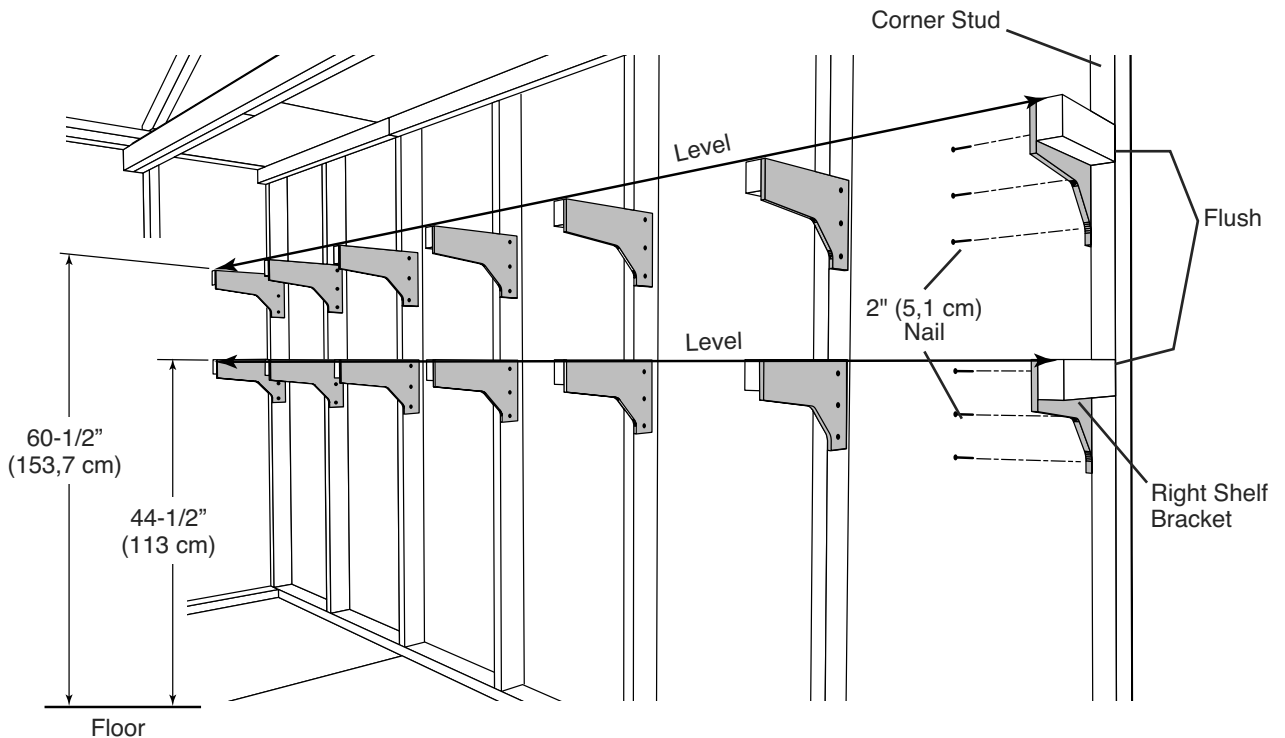
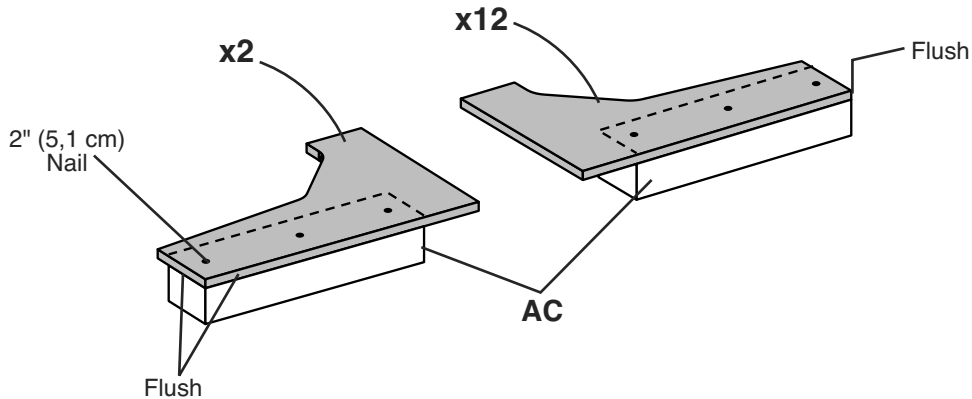

GABLE 12' x 12'

GABLE 12' x 16'

GABLE 12' x 20'

GABLE 12' x 24'

SHELF INSTALLATION

PARTS REQUIRED:

x2 
 7/16 x 11-1/4 x 96" OSB (1,1 x 28,6 x 243,8 cm OSB)

x2 
 7/16 x 11-1/4 x 47-7/8" OSB (1,1 x 28,6 x 121,6 cm OSB)

x2 **KP** 
 1 x 4 x 96" (2,5 x 10,2 x 243,8 cm)

x2 **WJ** 
 1 x 4 x 48" (2,5 x 10,2 x 121,6 cm)

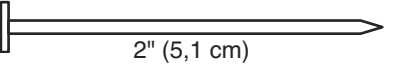
x68  2" (5,1 cm)



GABLE 12' x 12'

BEGIN

- 1 Install shelf panels centered over shelf supports. Secure with two 2" (5,1 cm) nails at each support
- 2 Secure **WJ** and **KP** with two 2" (5,1 cm) nails at each support and three 2" (5,1 cm) nails at seams.

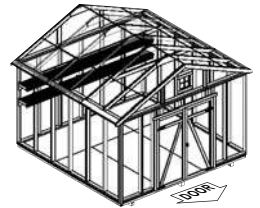

FINISH

- 3 You have finished installing your shelves.

GABLE 12' x 16'

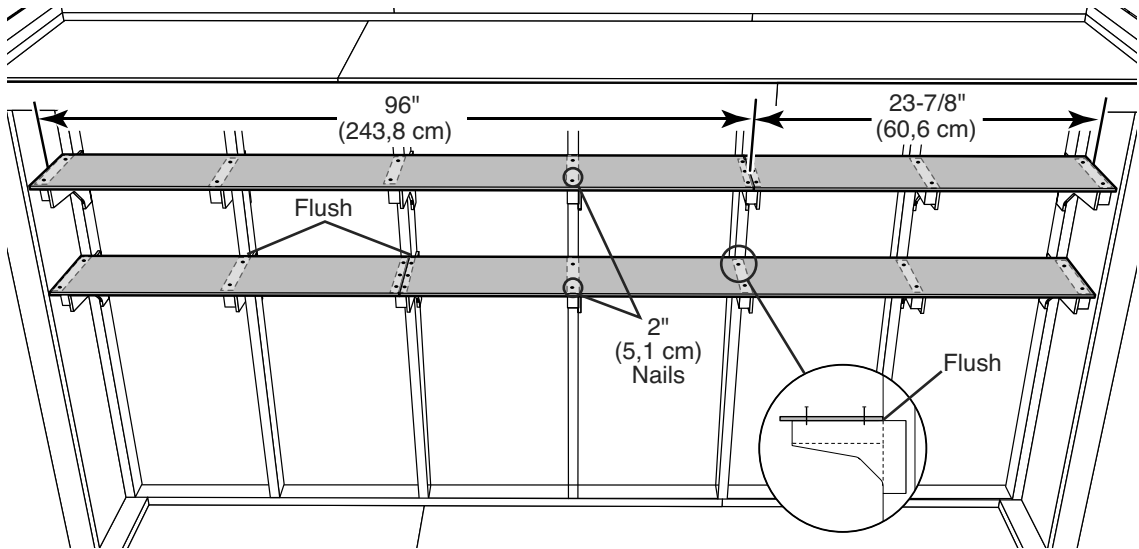

GABLE 12' x 20'

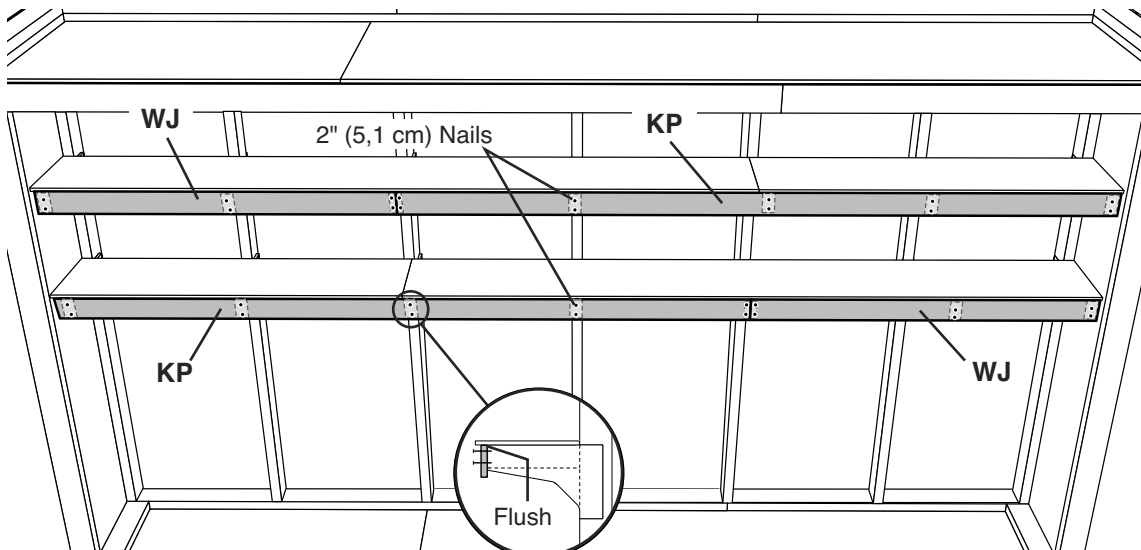

GABLE 12' x 24'

DOORS

PARTS REQUIRED:

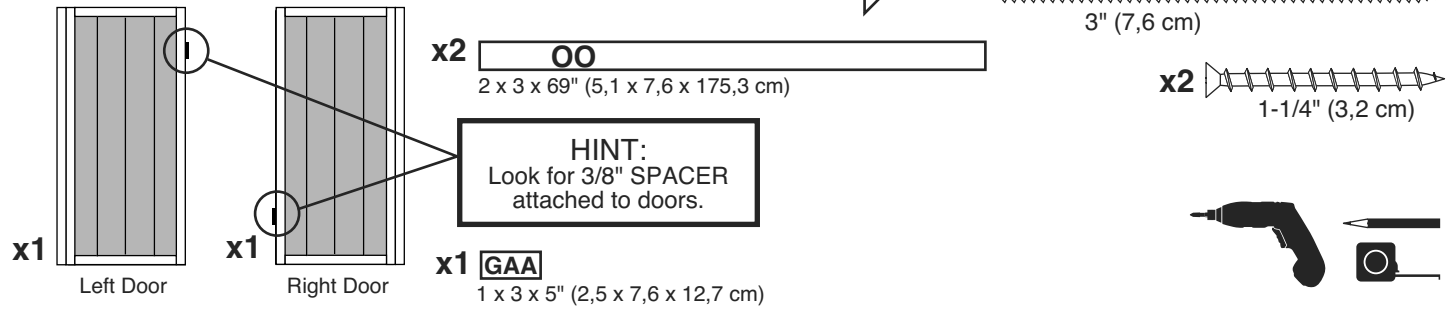

✓ BEGIN

- 1 Orient parts as shown on flat surface. **⚠ 3/8" offset is to top. Look for red (right) and green (left) on hinge board.**
- 2 Attach temporary supports **OO** with 3" screws in middle and at ends as shown. Tighten securely.
- 3 Attach temporary supports **GAA** with two 1-1/4" screws as shown. Tighten securely.

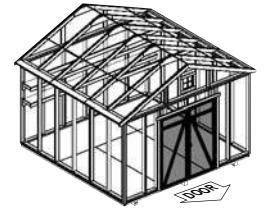

GABLE 12' x 12'

GABLE 12' x 16'

GABLE 12' x 20'

GABLE 12' x 24'

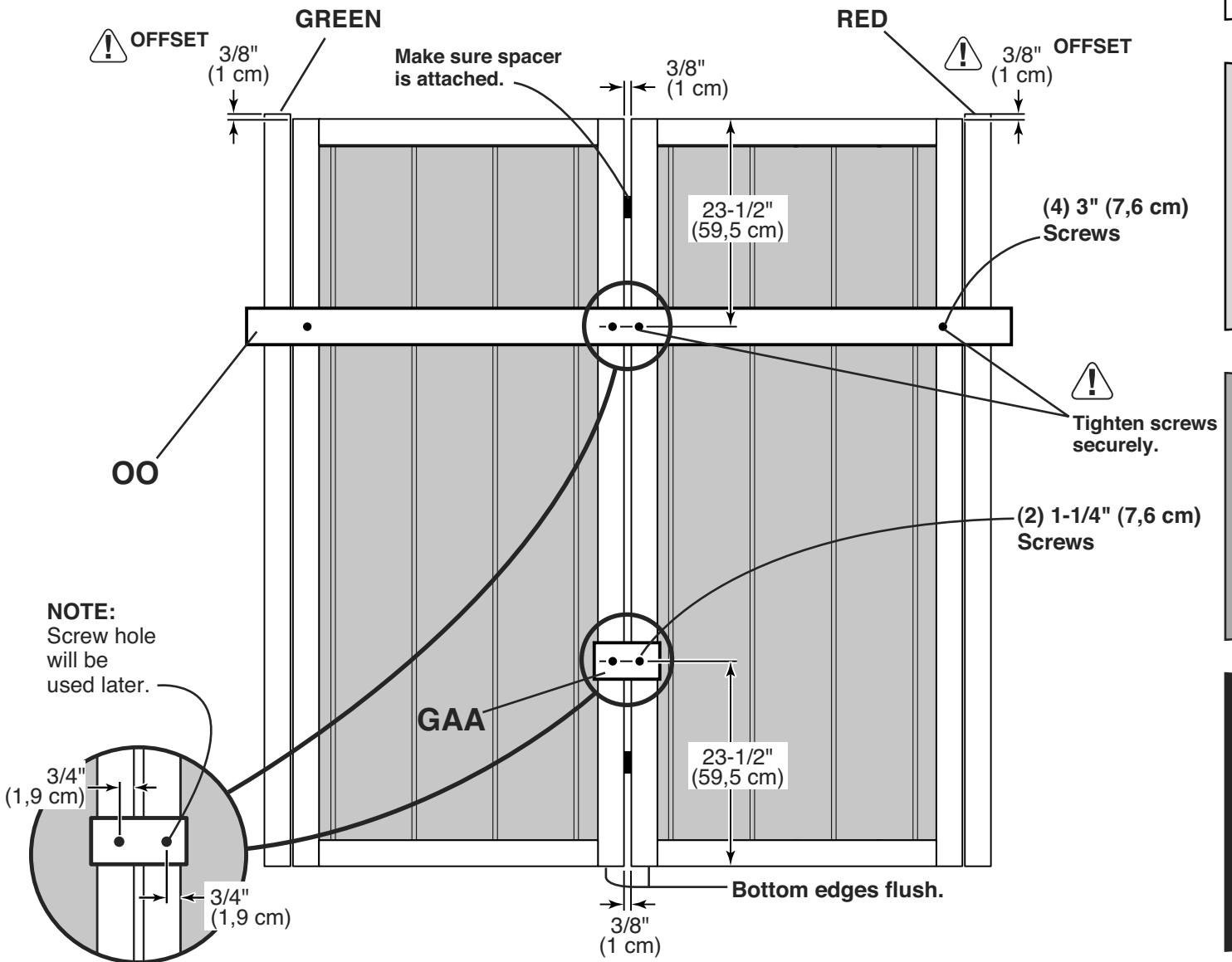

DOORS

PARTS REQUIRED:

x1  **OO**
2 x 3 x 69" (5,1 x 7,6 x 175 cm)

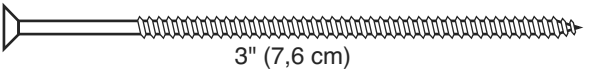
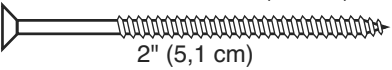
x7  3" (7,6 cm)
x6  2" (5,1 cm)

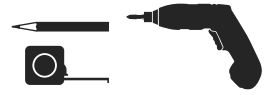

4 Attach temporary support **OO** as a ledger board flush under wall panels for doors to rest on, using 3" screws (**Fig. A**).

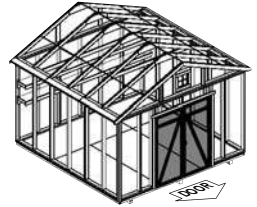
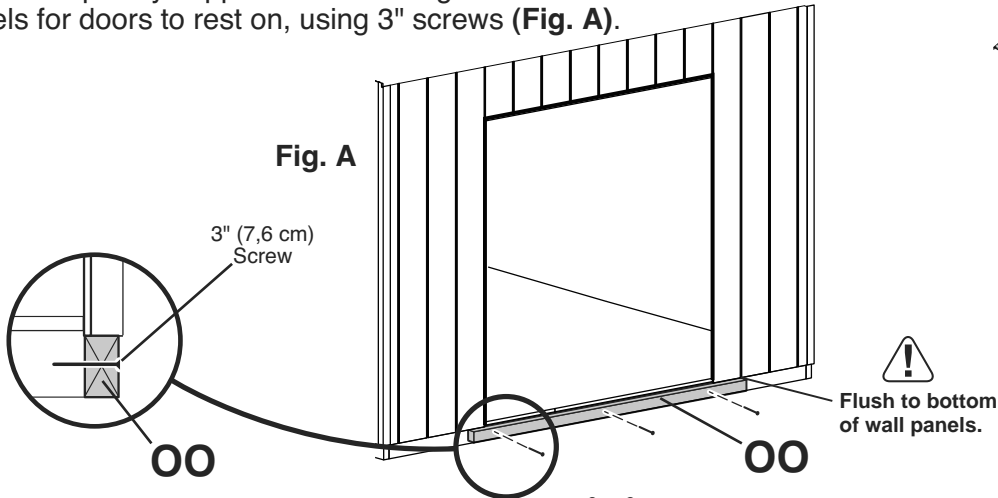

GABLE 12' x 12'

5 Center doors on panel seam as shown (**Fig. B**).
⚠️ Check ledger board is still flush under panels.



6 Screw hinge boards into wall supports and floor using four 3" screws as shown.
⚠️ Make sure screws go into framing and floor (**Fig. C, D**).

7 Screw hinge boards into wall supports and floor using six 2" screws as shown.
⚠️ Make sure screws go into wall framing (**Fig. C**).

8 Remove temporary supports and check doors open properly.

GABLE 12' x 16'



9 You have finished installing your doors.

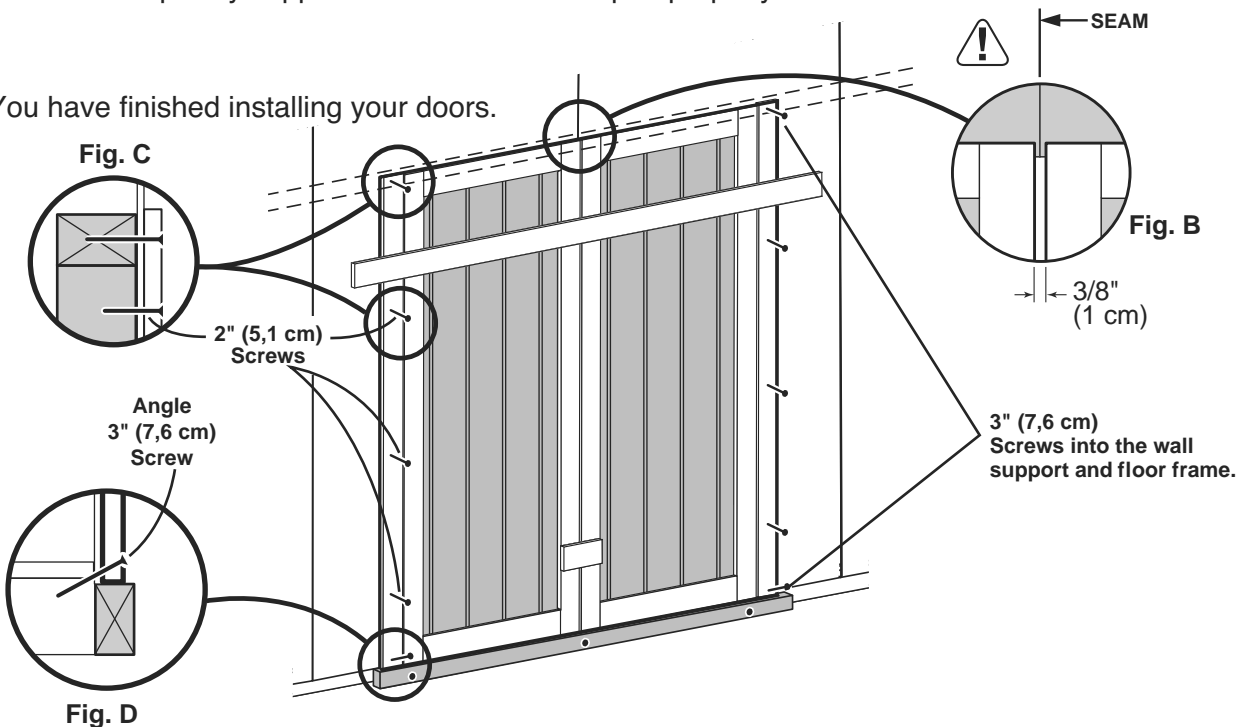

GABLE 12' x 20'

GABLE 12' x 24'

DOOR WEATHERSTRIP

PARTS REQUIRED:

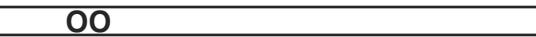
x2 
 2 x 3 x 69" (5,1 x 7,6 x 175 cm)

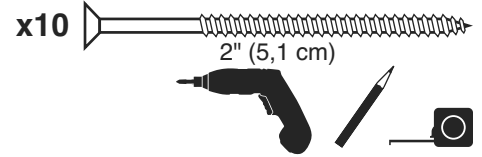

✓ BEGIN

- 1 With left door closed, center a weatherstrip **OO** vertically on the left door in the door opening (**Fig. A**). **OO** will offset the left door 1" OUT past the door trim 1" (**Fig. B**).
- 2 Secure **OO** using five 2" (5,1 cm) screws through outside trim into **OO** (**Fig. B**).
- 3 On right door center **OO** vertically in door opening (**Fig. A**). **OO** will offset the right door 1" IN from the door trim (**Fig. C**).
- 4 Secure **OO** using five 2" (5,1 cm) screws through outside trim into **OO** (**Fig. C**).

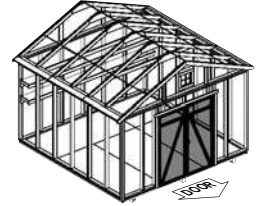

FINISH

- 5 You have finished installing your door weatherstrips.

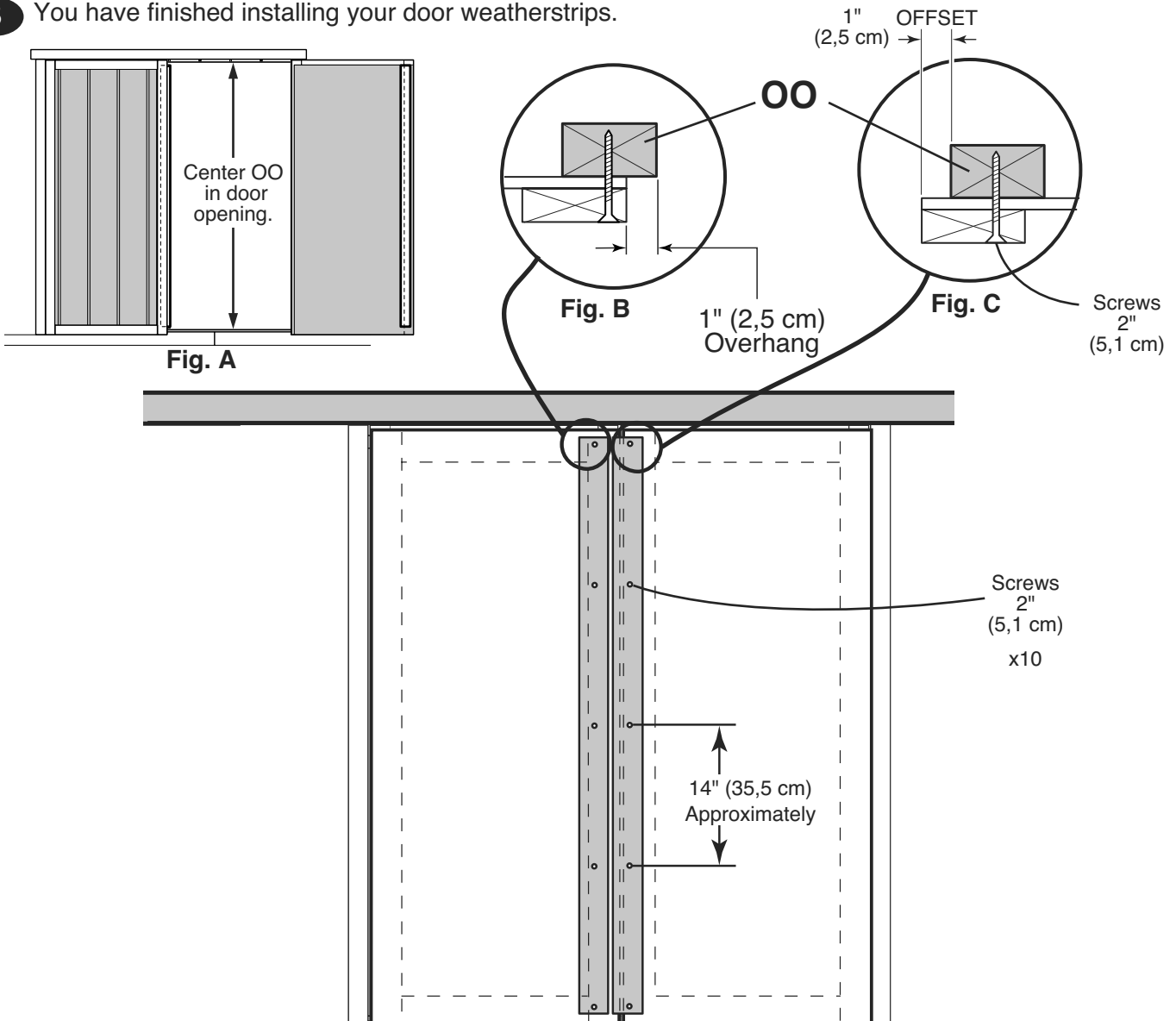

GABLE 12' x 12'

GABLE 12' x 16'

GABLE 12' x 20'

GABLE 12' x 24'

DOORS



PARTS REQUIRED:

x2 **AHR/AHL**
19/32 x 3 x 62" @ 22.5° (1,5 x 7,6 x 157,5 cm @ 22,5°)

x2 **AH**
19/32 x 3 x 26 5/8" (1,5 x 7,6 x 67,6 cm)

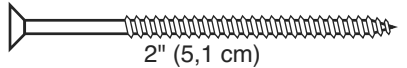
x1 **ZJ**
19/32 x 3 x 72" (1,5 x 7,6 x 182,9 cm)

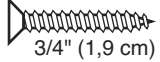
x7  2" (5,1 cm)

x66  3/4" (1,9 cm) 

✓ BEGIN

- 1 Reinforce the door trim using 3/4" (1,9 cm) screws through door panel into trim (Fig. A). Locate screws as shown in Fig. B. Use two screws at seams.

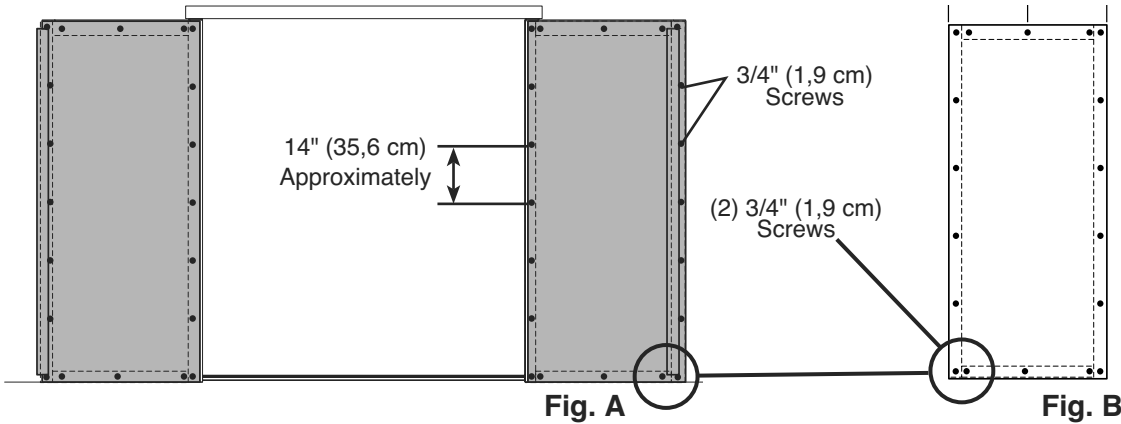
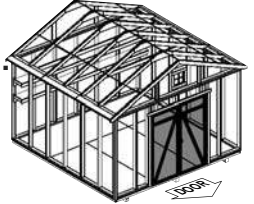

GABLE 12' x 12'

- 2 Center trim **ZJ** over doors and secure using seven 2" finish nails into framing as shown.
- 3 Remove 3/8" spacers from doors.
- 4 Level **AH** and **AHL** as shown and secure from inside with eleven 3/4" (1,9 cm) screws.

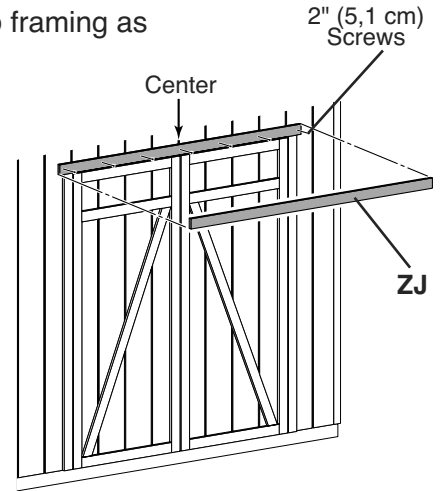

GABLE 12' x 16'

FINISH

- 5 You have finished securing your door and trim.

GABLE 12' x 20'

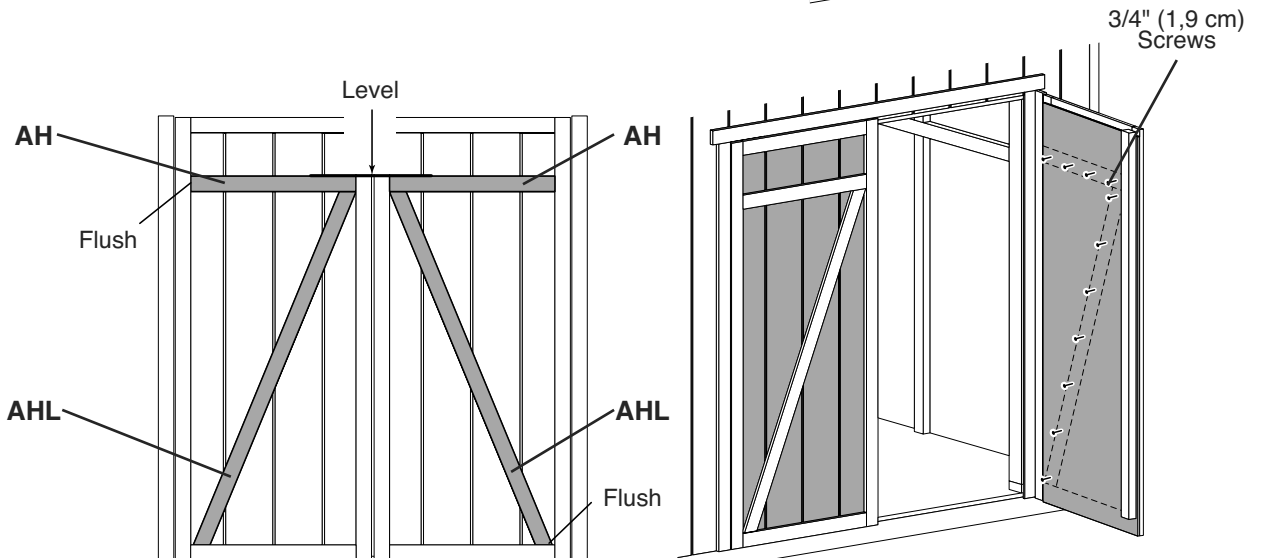

GABLE 12' x 24'

DOORS

PARTS REQUIRED:

x1 64" Metal Threshold

x11 3/4" (1,9 cm)
Special coating
Bagged separately

x4

x12 3/4" (1,9 cm)
Black /
Bagged separately

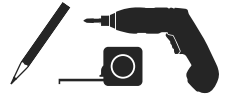

✓ BEGIN

- 1 Center Door Threshold between door opening.
- 2 Secure Threshold using eleven 3/4" (1,9 cm) screws.

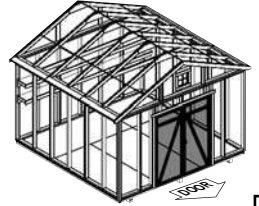

FINISH

- 3 You have finished installing your door Threshold.

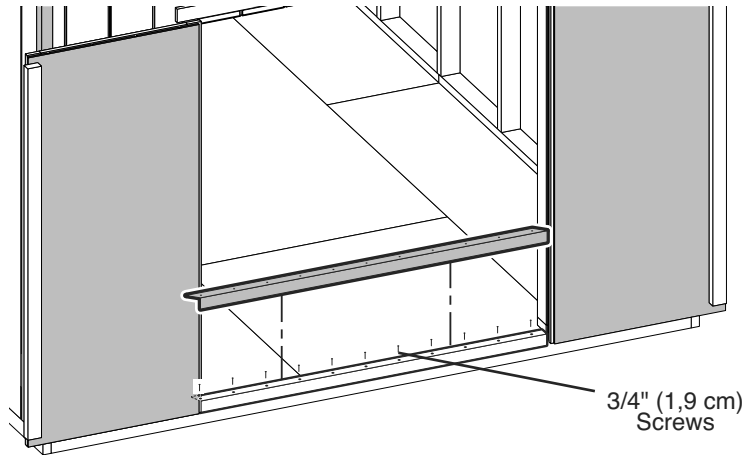

GABLE 12' x 12'

GABLE 12' x 16'

✓ BEGIN

- 1 Level decorative hinges in position as shown and secure with 3/4" (1,9 cm) screws.

FINISH

- 2 You have finished installing your decorative door hinges.

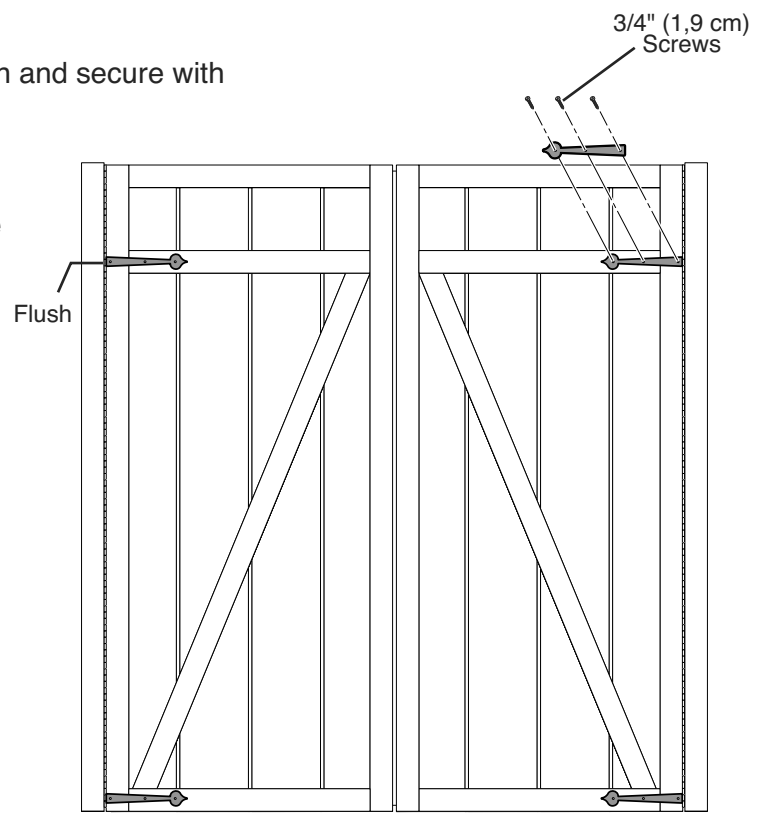

GABLE 12' x 20'

GABLE 12' x 24'

DOOR HARDWARE

PARTS REQUIRED:

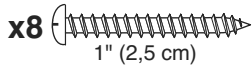
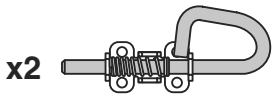

✓ BEGIN

1 Place upper bolt onto **OO** in open position with bolt end 1/4" down from frame. Bolt is open when loop is contacting base (**Fig A**). Mark and pre-drill holes for screws.

2 Install bolt with screws supplied and drill 5/16" hole for bolt to extend into door frame.

3 Place lower bolt onto **OO** in open position with bolt end 1/2" above floor. Bolt is open when loop is contacting base (**Fig B**). Mark and pre-drill holes for screws.

4 Install bolt with screws supplied and drill 5/16" hole for bolt to extend into floor.

FINISH

5 You have finished mounting your door bolts.

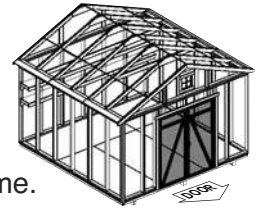

GABLE 12' x 12'

GABLE 12' x 16'

GABLE 12' x 20'

GABLE 12' x 24'

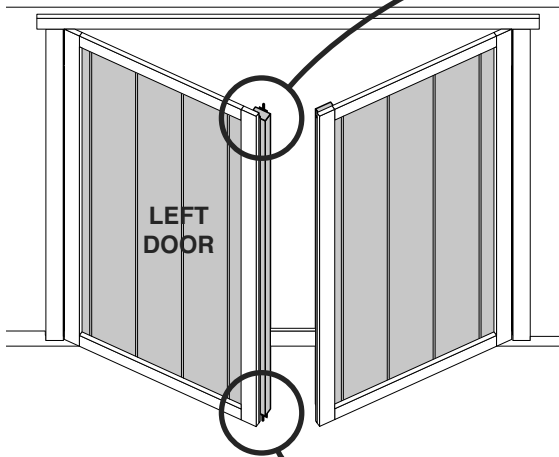

Fig. A

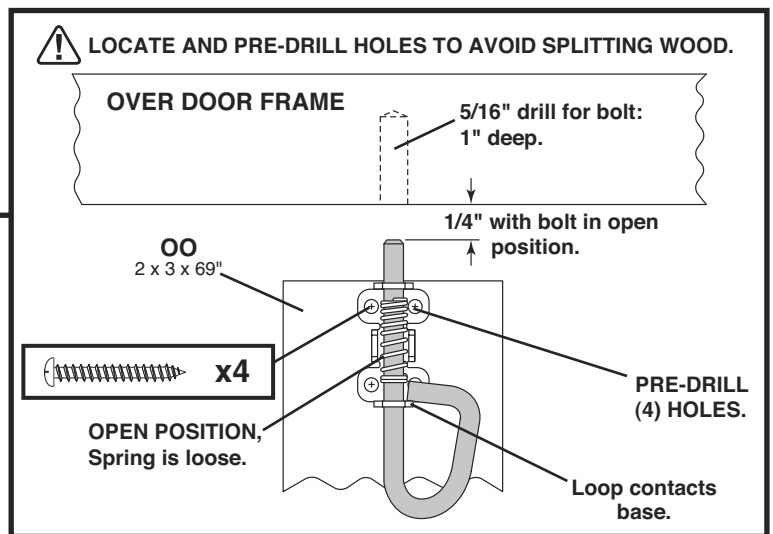
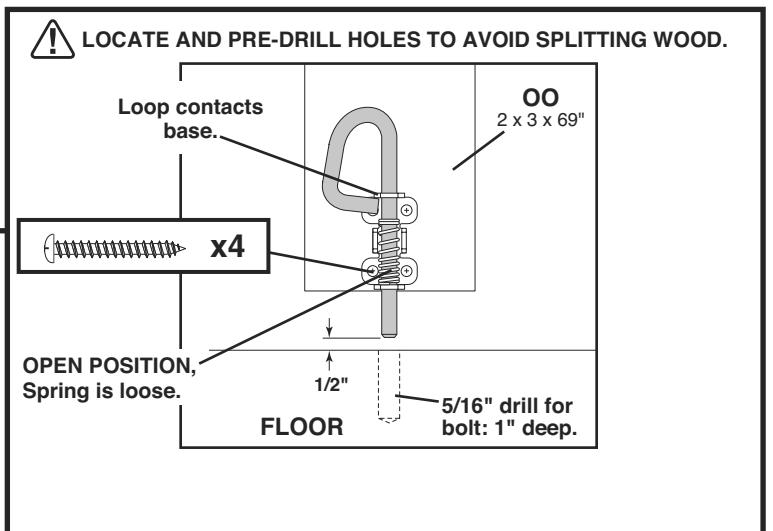

Fig. B





HINT: With door closed extend bolt and tap with hammer to leave a mark in wood for drilling.

DOOR HARDWARE

PARTS REQUIRED:

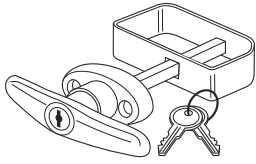
x1



x2  1-1/2" (38 mm)

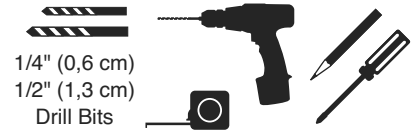

✓ BEGIN

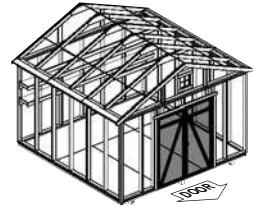

- 1 Measure and mark position on right door as shown.
- 2 Pre-drill 1/4" hole at mark. Finish hole with 1/2" drill bit.
- 3 Position hardware in hole and secure with screws as shown.

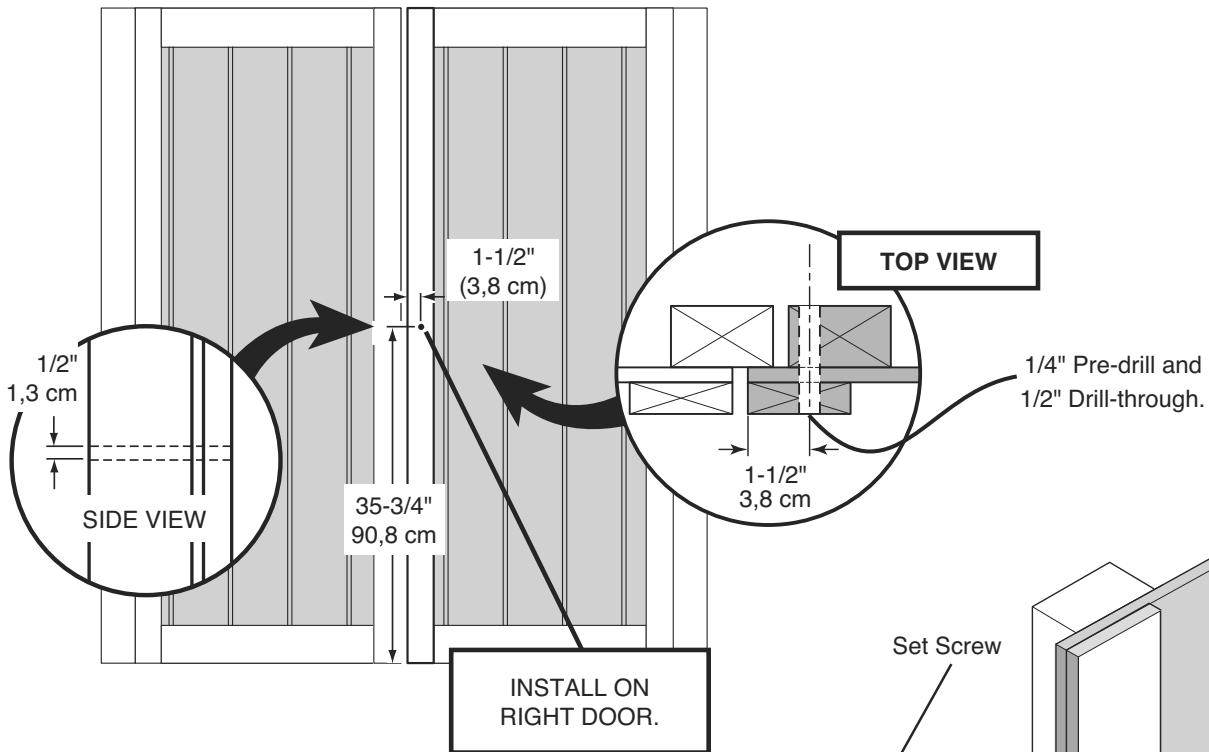

FINISH

- 4 You have finished mounting your door hardware.

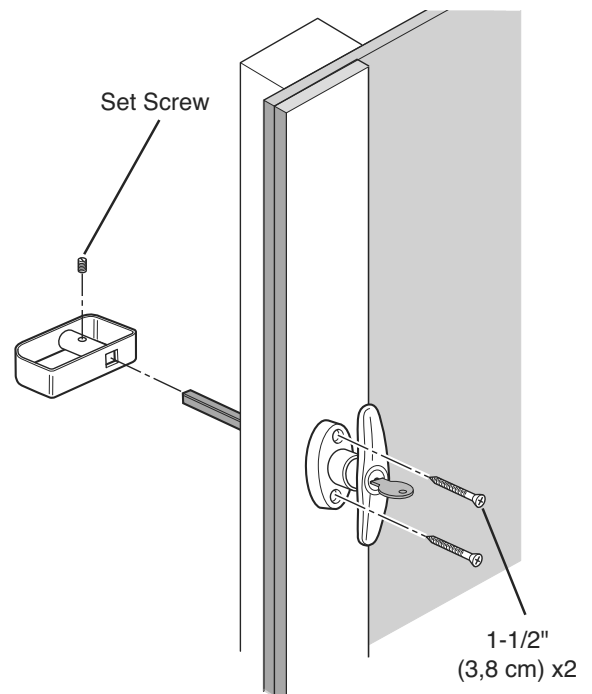

GABLE 12' x 12'

GABLE 12' x 16'

GABLE 12' x 20'

GABLE 12' x 24'

FRONT GABLE WINDOW

PARTS REQUIRED:

x2 **DI**
5/8 x 3 x 12" (1,6 x 7,6 x 30,5 cm)

x2 **EU**
5/8 x 3 x 17" (1,6 x 7,6 x 43,2 cm)

x1
12 x 12"
(30,5 x 30,5 cm)

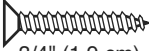
x8 
3/4" (1,9 cm)

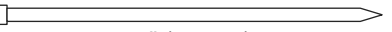
x14 
2" (5,1 cm)



✓ BEGIN

- 1 Position window in front gable as shown and secure with 3/4" screws.
- 2 Seal window with high quality paintable exterior caulk.



GABLE 12' x 12'

GABLE 12' x 16'

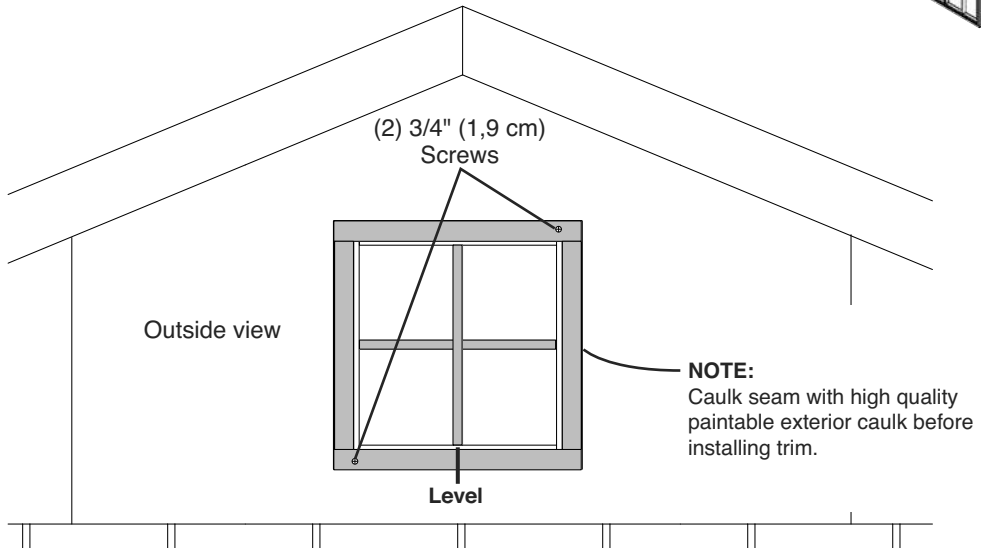

- 3 Center trim over window. Tack in place with 2" finish nails.
- 4 Secure trim with 3/4" screws from inside.

FINISH

- 5 You have finished mounting your window.

GABLE 12' x 20'

GABLE 12' x 24'

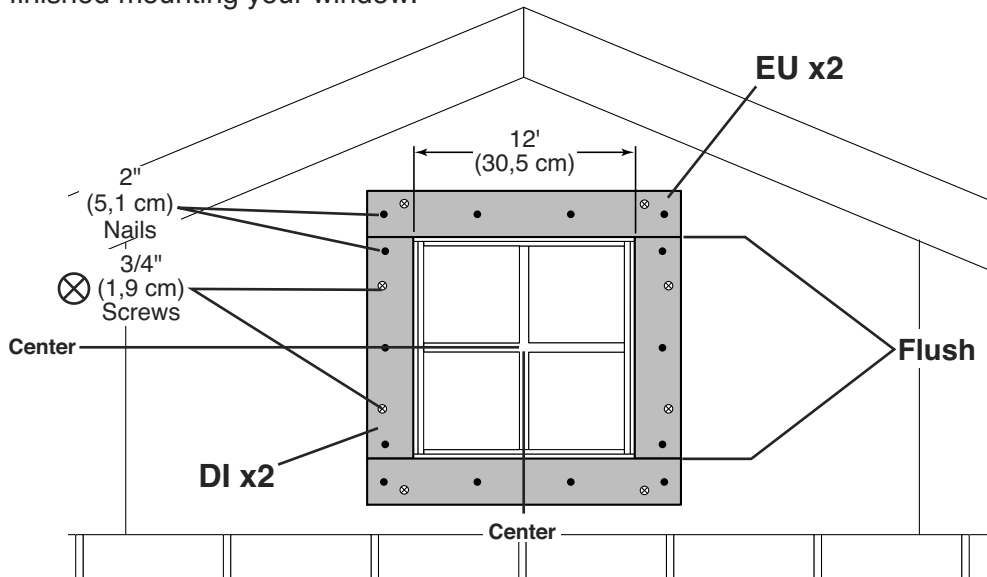

VENT

PARTS REQUIRED:

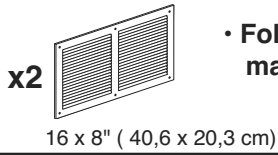

• Follow directions provided by manufacturer and these instructions.

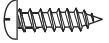

x12 
1/2" (1,3 cm)

✓ BEGIN

- 1 Locate and mark for two vents in side walls as shown. One at top and one at bottom.

Cut out marked openings.

Caulk behind vent flanges.

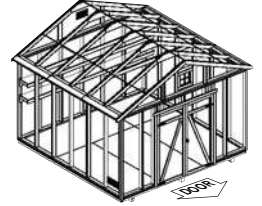

- 2 Secure using 1/2" (1,3 cm) screws



FINISH

- 3 You have finished installing your vents.

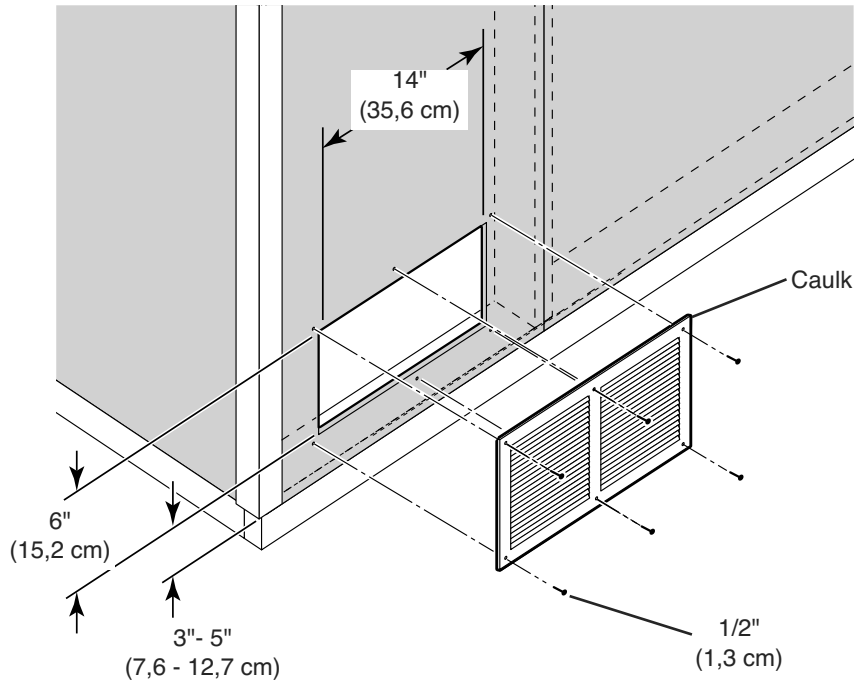

GABLE 12' x 12'

GABLE 12' x 16'

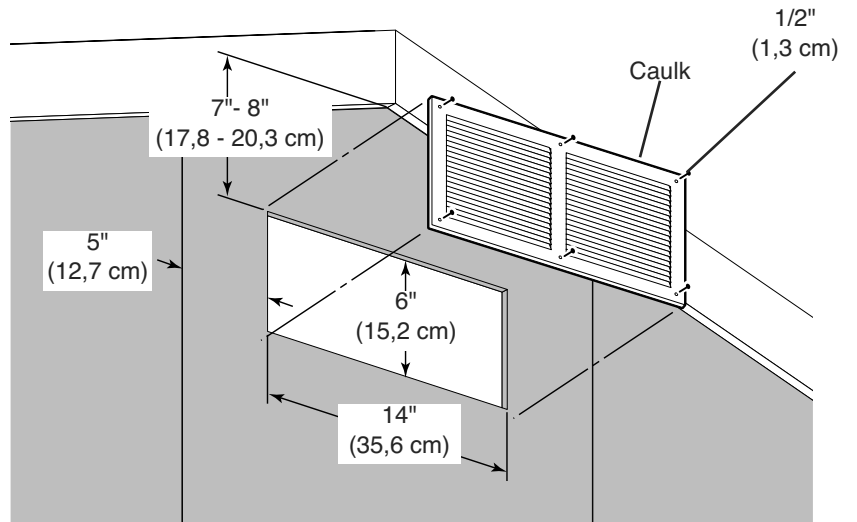

GABLE 12' x 20'

GABLE 12' x 24'

PAINT & CAULK

- NOT INCLUDED -

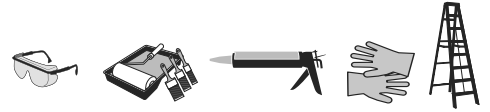

- Use acrylic latex caulk that is paintable. Caulk at all horizontal and vertical seams, between the trim and walls, and all around the door trim.
- Use a high quality exterior acrylic latex paint. When painting your building, there are a few key areas that can be easily overlooked that must be painted:
 - Bottom edge of all siding and trim
 - Inside of doors and all 4 edges

Note:

Prime all un-primed exterior wood before painting.
(Follow directions provided by manufacturer.)

GABLE 12' x 12'

ROOF FELT

- NOT INCLUDED -

- Install felt flush to all roof edges overlapping 3". Use minimal amount of roofing nails to hold in place.

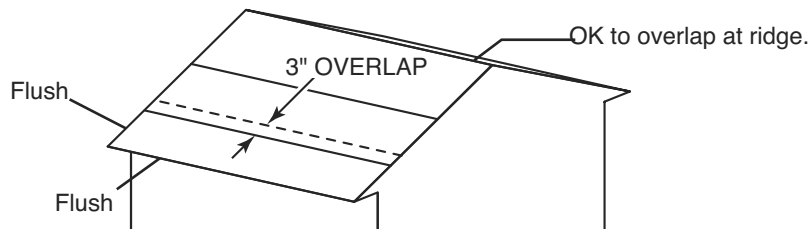

GABLE 12' x 16'

DRIP EDGE

- NOT INCLUDED -

- Install drip edge over roof felt on gable side and under roof felt on eave side (Fig. A).
- Do not use nails on side of drip edge that hangs over side of building.
- Only nail top of drip edge as shown.



GABLE 12' x 20'

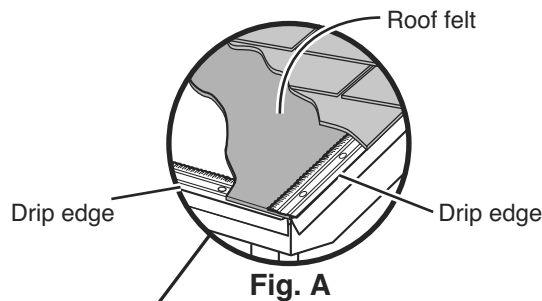

GABLE 12' x 24'

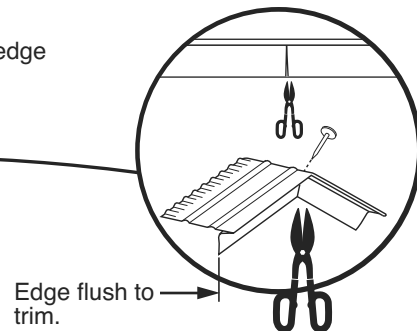
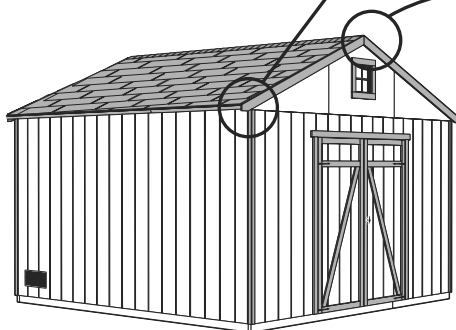

Snip bottom side of drip edge and bend over to other side of roof.

(Follow directions provided by manufacturer.)

NOTE: 12' x 12' Model Shown.

SHINGLES

- NOT INCLUDED -

• Follow directions provided by manufacturer and these instructions.

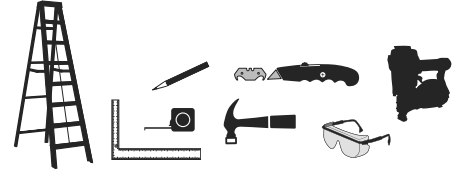

! Familiarize yourself with a 3-Tab Shingle.

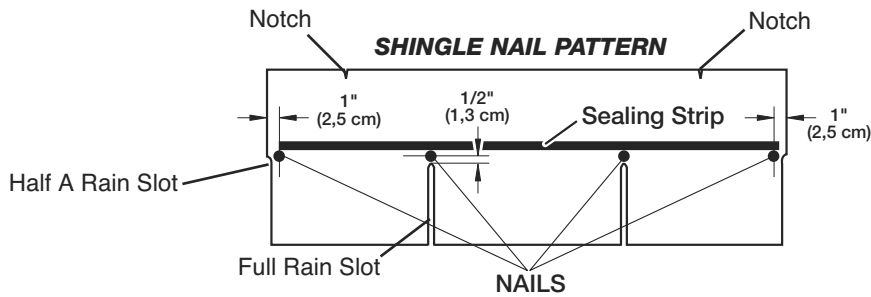

! NEVER DRIVE FASTENERS INTO OR ABOVE SEALING STRIPS.

✓ BEGIN

- 1 Install first starter row upside down and color up with a 1" overhang at back and bottom of roof panel. Use (4) nails per shingle. Starter row must be straight and level all the way across with lower edge of roof deck.
NOTE: If you have installed drip edge install shingles flush to drip edge.

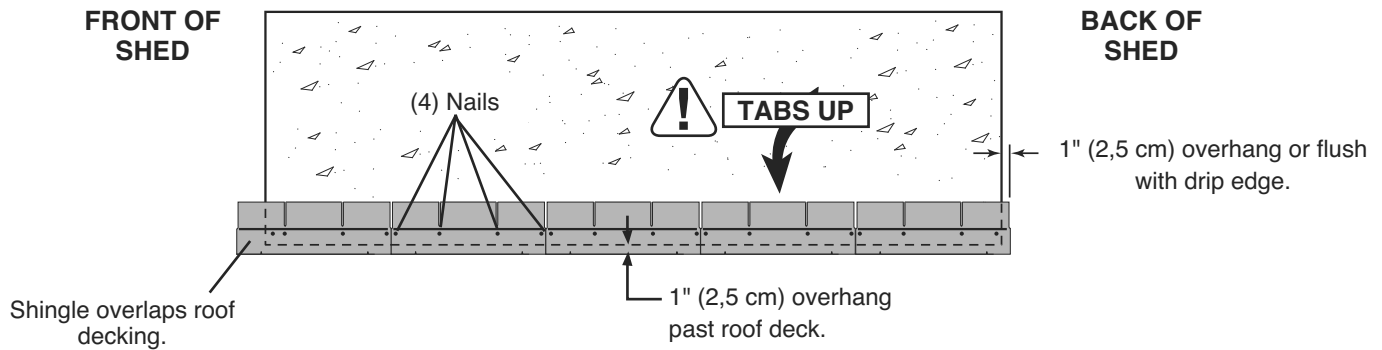

GABLE 12' x 12'

GABLE 12' x 16'

GABLE 12' x 20'

GABLE 12' x 24'

SHINGLES

continued...

- 2 Beginning at front of shed, install first row of shingles with notch at 1" past roof edge or flush with drip edge.

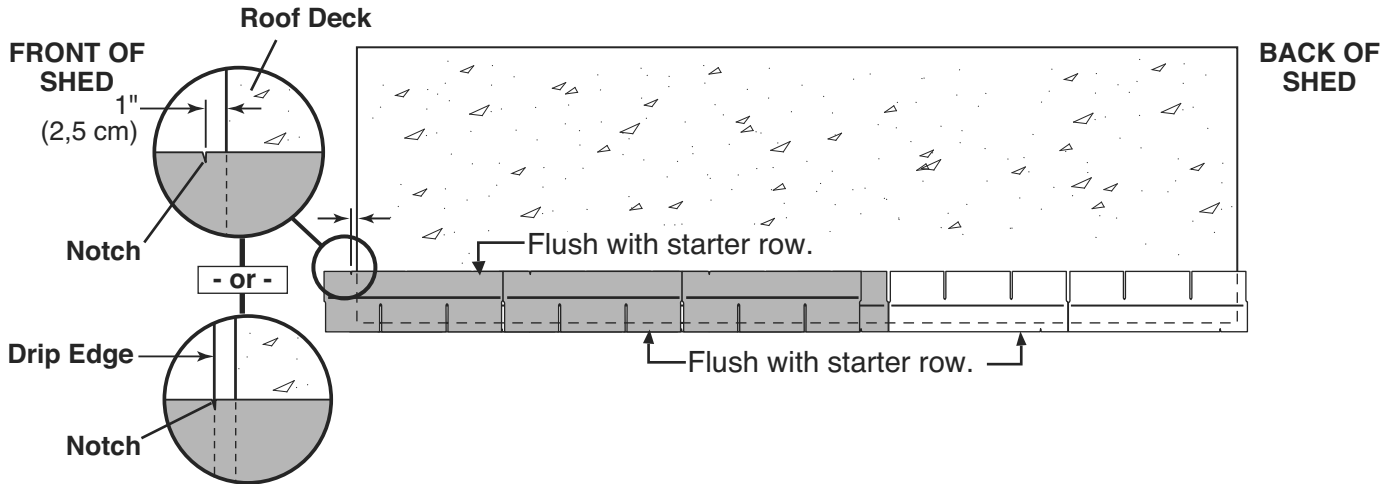

- 3 Install second row of shingles flush at top of first row's rain slots. Ensure 1" overhang or flush to drip edge at front, stagger each row.

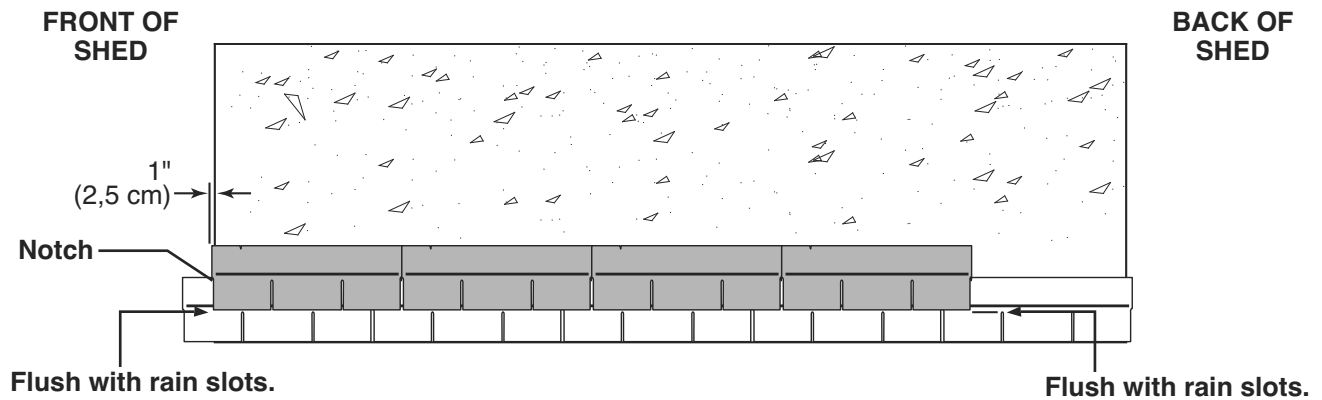

- 4 Continue installing rows of shingles by staggering at front.

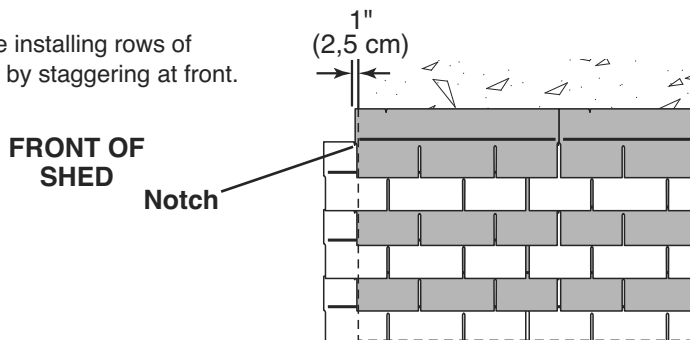

SHINGLES

continued...

- 5 Continue installing rows of shingles to the peak. At the peak make sure there is a maximum of 5" or less to the rain slot, as shown below. If shingles overlap at ridge cut to peak with a utility knife.

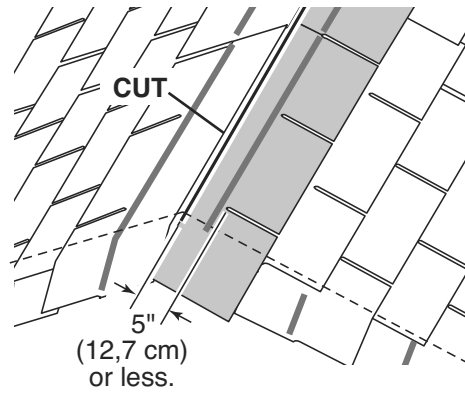
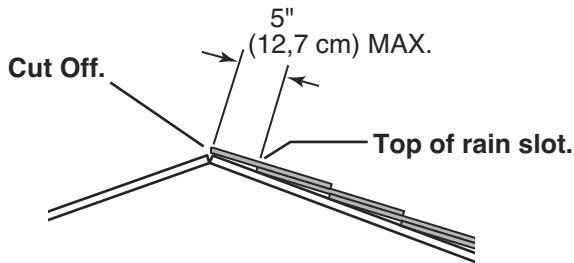

- ! • If more than 5" to rain slot you must install another row of shingles.

- 6 Repeat steps 1 - 7 to shingle the opposite side of your roof. Trim shingles at ridge.

- 7 Once both sides are shingled you need to trim ends. Strike a chalk line 1" from edge.

- 8 Using your shingle hooked blade carefully cut shingles along chalk line.

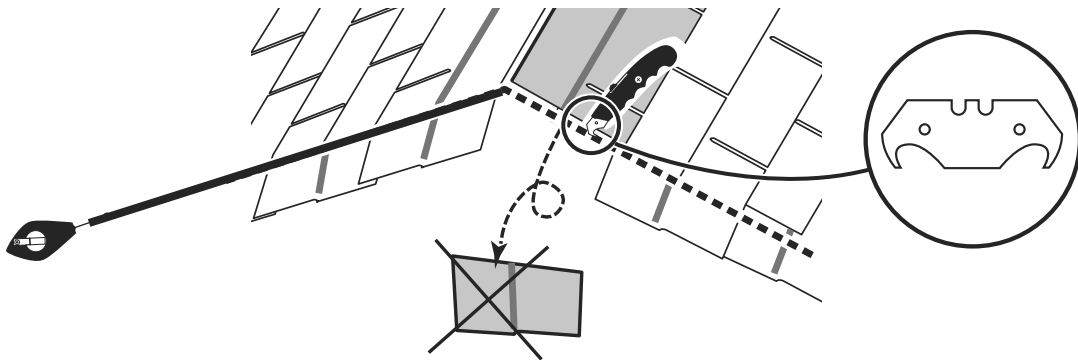

- 9 You have finished shingling your roof. Proceed to capping the ridge.

GABLE 12' x 12'

GABLE 12' x 16'

GABLE 12' x 20'

GABLE 12' x 24'

SHINGLES - RIDGE CAP

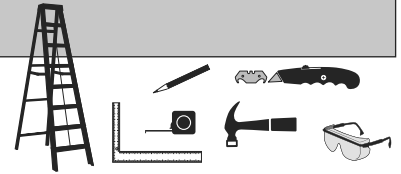

• You will finish off the top of the roof with a ridge cap made from shingles.

✓ BEGIN

1 Cut shingles into THREE pieces. Hint: Use cut-off pieces first.

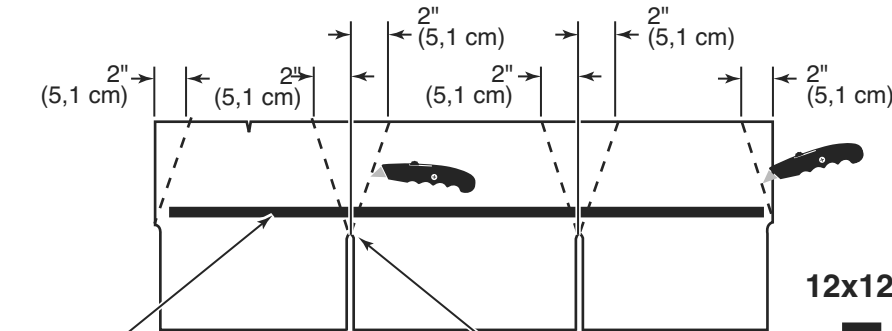

Score shingle, then snap-off angled cut.

Weather Seal

Top of slot.

Note: • You will need about 28 - 30 cut pieces for 12' x 12' model
 38 - 40 cut pieces for 12' x 12' model
 48 - 50 cut pieces for 12' x 12' model
 57 - 60 cut pieces for 12' x 12' model

12x12'

12x16'

12x20'

12x24'

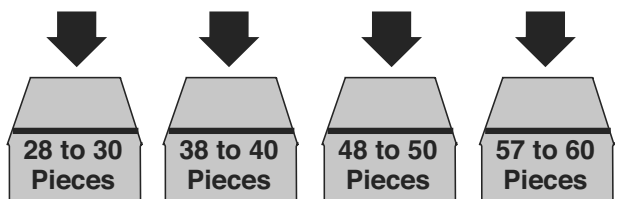

GABLE 12' x 12'

2 Install first ridge cap flush to shingles at front, as shown.

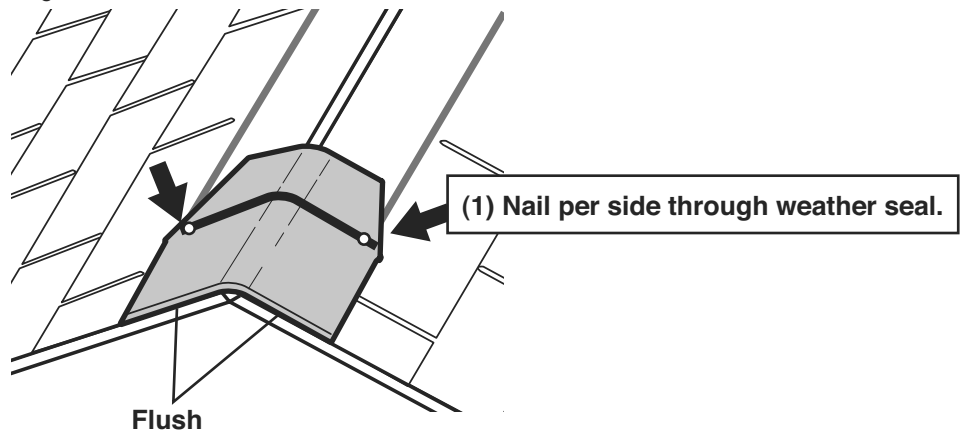

GABLE 12' x 16'

3 Install second ridge cap 5" back, as shown.

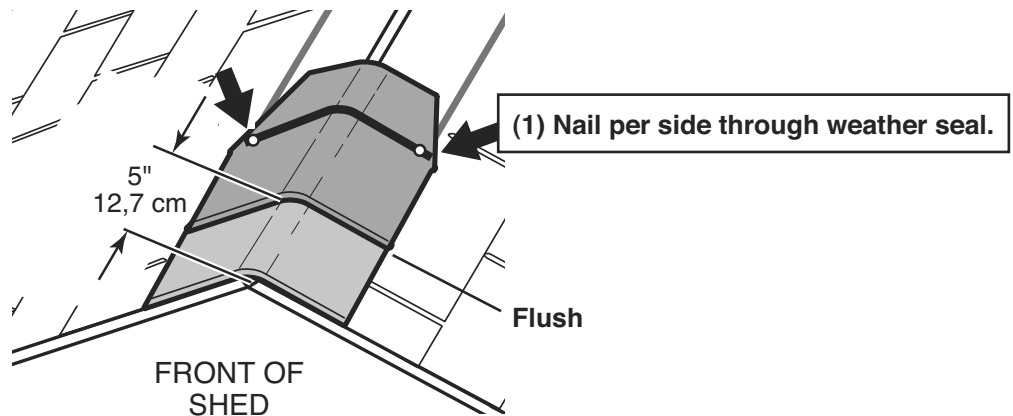

GABLE 12' x 20'

GABLE 12' x 24'

SHINGLES - RIDGE CAP

continued...

- 4 Continue installing ridge cap to back of roof.

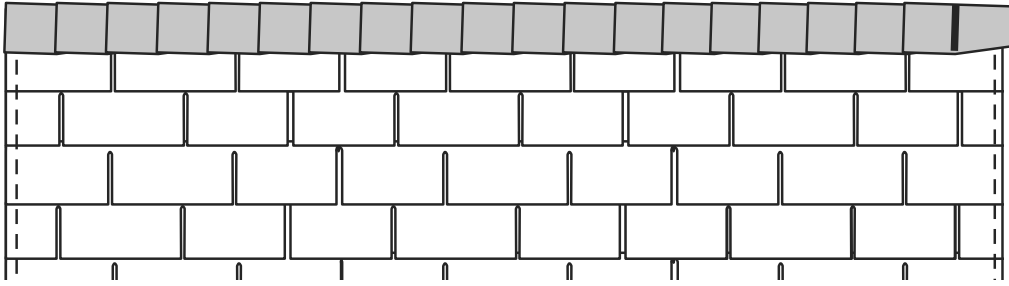

- 5 Make sure there is 4" between the shingle-color and edge of shingles.

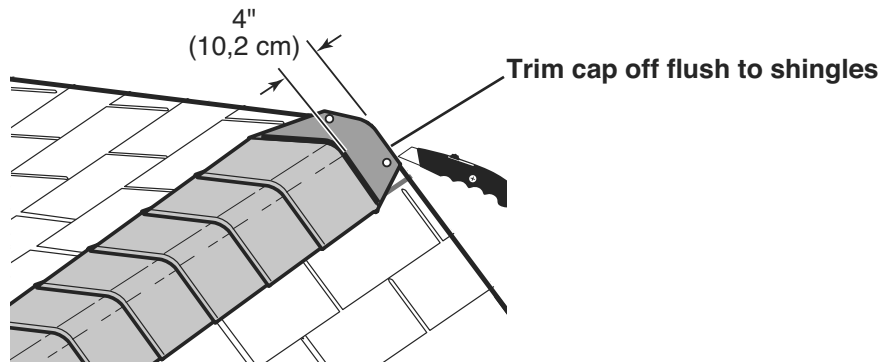

- 6 When you have 4" minimum of shingle color cut one piece to cap your roof.

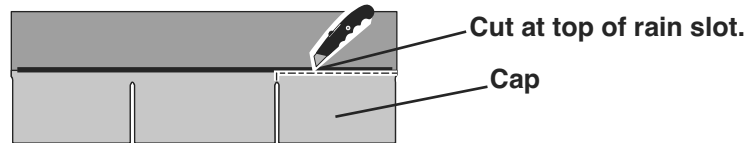

- 7 Install flush to shingles.

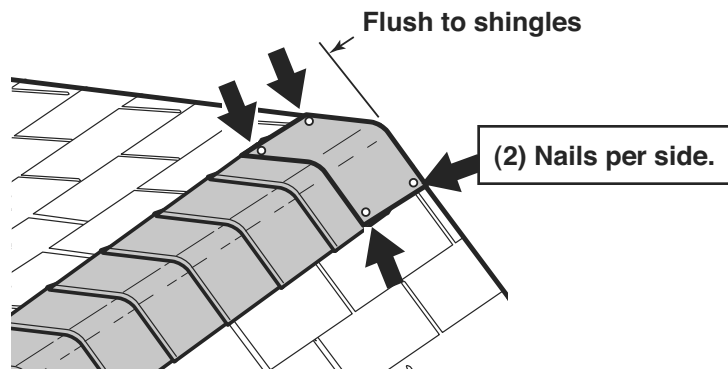

- 8 You have finished your ridge cap.

GABLE 12' x 12'

GABLE 12' x 16'

GABLE 12' x 20'

GABLE 12' x 24'

WARRANTY

Backyard Storage Solutions, LLC warrants the following:

1. Every product is warranted from defects in workmanship and manufacturing for one year.
2. All hardware and metal components are warranted for two years.
3. Trim is warranted for 10 years.
4. Waferboard siding and sheathing is warranted for two years.
5. SmartSide™ siding is warranted for 10 years on all Marco series buildings and 15 years on all Premier Series buildings.
6. Timber series buildings' siding and trim are warranted for 10 years.
7. Solar Shed windows are warranted for 1 year.
8. Cedar lumber is warranted for 15 years.
9. Cedar doors and Cedar Garden Center are warranted for 10 years.
10. Metal roof is warranted for 25 years.

**Limited Conditional
Warranty ***

Backyard Storage Solutions, LLC will repair, replace or pay for the affected part. In no event shall Backyard Storage Solutions, LLC pay the cost of labor or installation or any other costs related thereto. All warranties are from date of purchase. If a cash refund is paid on an affected part, it will be prorated from the date of purchase.

CONDITIONS

The warranty is effective only when:

1. The unit has been erected in accordance with the assembly instructions.
2. The unit has been properly shingled and painted or stained and reasonably and regularly maintained thereafter.
3. The failure occurs when the unit is owned by the original purchaser.
4. Backyard Storage Solutions, LLC has received the warranty registration card within thirty (30) days of purchase and notification of the failure in writing within the warranty period specified above.
5. Backyard Storage Solutions, LLC has had reasonable opportunity during the sixty (60) days following receipt of notification to inspect and verify the failure prior to commencement of any repair work.

REQUIREMENTS

Storage Buildings & Playhouses

To validate your warranty, it is necessary to properly maintain your Backyard Storage Solutions, LLC unit; shingle the roof and paint or solid-colored stain the siding using 100% acrylic latex exterior product with a minimum of two (2) coats within thirty (30) days of assembly; caulk above all doors and all horizontal and vertical trim boards; paint and seal all exposed edges, sides and faces of SmartSide™ and waferboard siding to include all exterior walls and all sides and all edges of doors.

Gazebos, Pergolas & Timber Buildings

To validate your warranty, it is necessary to properly maintain your Backyard Storage Solutions, LLC unit. This includes treating all of the exposed cedar and pine surfaces on your gazebo or timber building with an exterior grade wood preservative, an exterior oil-based semi-transparent stain, an acrylic latex exterior paint or an acrylic latex solid color exterior stain within 30 days of assembly and as needed thereafter to maintain your warranty.

Keep vegetation trimmed away from building and make sure siding panels and trim do not come in contact with masonry or cement. The minimum ground clearance for siding must be one half inch (½ inch) from concrete slab or two and one half inches (2 ½") from the ground when building is erected or constructed on a treated wood floor kit. Water from sprinklers must be kept off unit. In no event will Backyard Storage Solutions, LLC be responsible for any indirect, incidental, consequential or special damages nor for failure(s) that are caused by events, acts or omissions beyond our control including, but not limited to, misuse or improper assembly, improper maintenance (which eventually leads to rot or decay) and acts of God. Backyard Storage Solutions, LLC will not be held responsible for any labor costs incurred to construct your unit. This warranty gives you certain specific rights that vary from state to state.

CLAIM PROCEDURE

To make a claim under this warranty, you can either call 1-888-827-9056 or prepare a letter. Please have ready the information below when you call or include the information when writing:

1. The model and size of the product.
2. A list of the part(s) for which the claim is made.
3. Proof of purchase of the Backyard Storage Solutions, LLC item, as shown on the original invoice.
4. Run code, as listed on the yellow warranty card enclosed in the product package.

Mail the above information to:

Backyard Storage Solutions, LLC
Attn: Customer Service
1000 Ternes
Monroe, MI 48162

***WARRANTY TERMS MAY VARY OUTSIDE THE U.S.A.**

IMPORTANT: This is your warranty certificate.

Please complete and mail your warranty card to properly validate your warranty.