

**16615-REV**



***Call Us First!***  
***DO NOT RETURN TO STORE.***

For immediate help with assembly or product information  
call our toll free number:

**1-888-827-9056**

or email:

***customerservice@backyardproductsllc.com***

Our staff is ready to provide assistance

April through October M-F 8:00 AM to 7:00 PM EST

Saturday 8:30 AM to 4:30 PM EST

November through March M - F 8:00 AM to 5:00 PM EST

***ANTES DE DEVOLVERLO, ¡LLÁMENOS!***

**Si desea más información sobre el montaje, llámenos sin coste  
adicional alguno al siguiente teléfono:**

**1-888-827-9056**

o correo electrónico:

***customerservice@backyardproductsllc.com***

Nuestro personal le proporcionará toda la ayuda que necesite.

Abril through Octubre M - F 8:00 EST a 7:00 PM EST

el Sabado 8:30 EST a 4:30 PM EST

Noviembre por Marzo M - F 8:00 EST a 5:00 PM EST

(This page intentionally left blank.)

(Esta página está intencionado en blanco.)

Customer Service  
Servicio al cliente  
1-888-827-9056  
1000 Ternes Drive  
Monroe, MI 48162

# 12' x 10' Gable Aguilón 366 x 305 cm

Includes 12' x 10' Building Instructions.

Incluye instrucciones del edificio 366 x 305 cm.

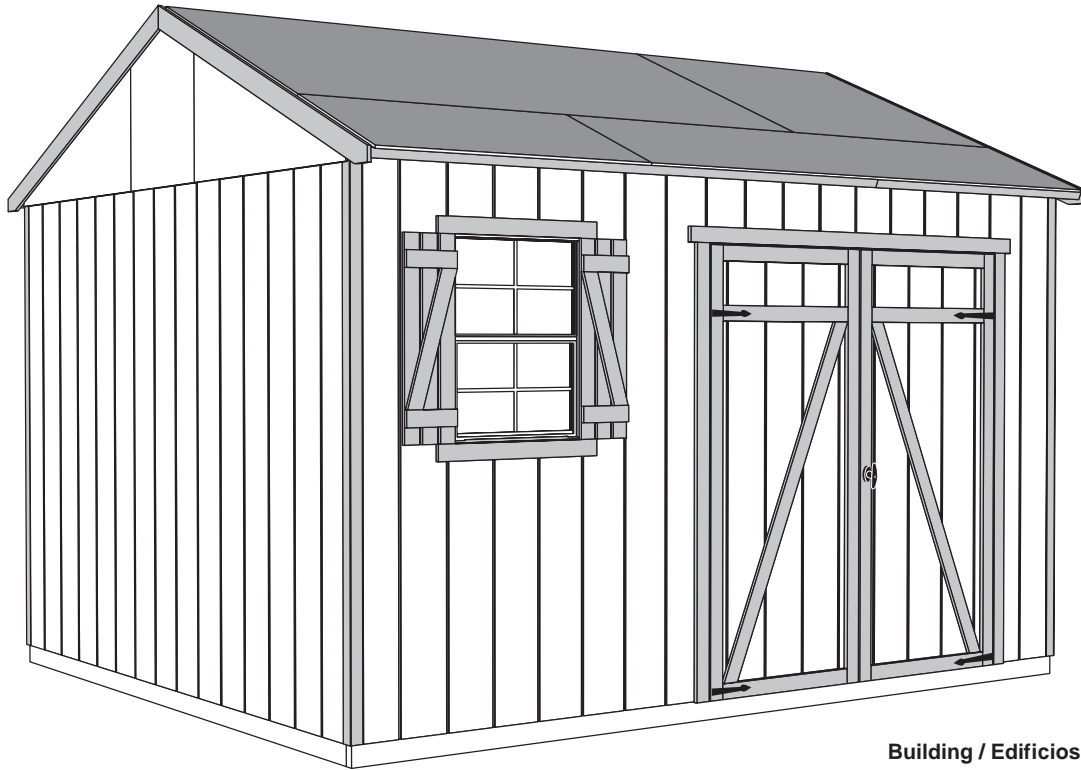

Building / Edificios  
12' x 10'  
(366 x 305 cm)

## TOOLS REQUIRED

- |  |                                       |   |  |
|--|---------------------------------------|---|--|
| <input type="checkbox"/> Electric drill with #2 Phillips Tip | <input type="checkbox"/> Pencil       | <input type="checkbox"/> Phillips Screwdriver | <input type="checkbox"/> Wood Glue     |
| <input type="checkbox"/> Nail Pouch                          | <input type="checkbox"/> Square       | <input type="checkbox"/> Hammer               | <input type="checkbox"/> Utility Knife |
| <input type="checkbox"/> Chalk Line                          | <input type="checkbox"/> Tape Measure | <input type="checkbox"/> Level                | <input type="checkbox"/> Caulk Gun     |
|  | <input type="checkbox"/> Ladder       | <input type="checkbox"/> Paint Tools          | <input type="checkbox"/> Clamps        |

## HERRAMIENTAS NECESARIAS

- |   |  |   |   |
|---|--|---|---|
| <input type="checkbox"/> Taladro eléctrico Broca "Phillips" | <input type="checkbox"/> Lápiz         | <input type="checkbox"/> Desmarador cruz          | <input type="checkbox"/> Pegamento para madera  |
| <input type="checkbox"/> Bolsillo para clavos               | <input type="checkbox"/> Escuadra      | <input type="checkbox"/> Martillo                 | <input type="checkbox"/> Navaja                 |
| <input type="checkbox"/> Cordeau                            | <input type="checkbox"/> Cinta métrica | <input type="checkbox"/> Nivel                    | <input type="checkbox"/> Pistolo para masillado |
|   | <input type="checkbox"/> Escalera      | <input type="checkbox"/> Herramientas para pintar | <input type="checkbox"/> Grapas                 |

We manufacture kits from select construction grade lumber and engineered wood products. Construction grade lumber, a product cut from trees, has many natural characteristics and blemishes that may be present in some of the pieces you receive in your kit. Natural characteristics and blemishes in construction lumber may include knots, torn wood grain along edges, minor cracks/splits, twists, limited bark along edges and pitch pockets that may exude sap. Be assured that the individual parts have been cut and inspected to remove as many of the wood's natural, less appealing characteristics as possible. These characteristics and/or blemishes will not affect the strength, durability, or structural integrity of the finished product. Generally, the exterior trim parts selected for your kit are graded from only one side and should be installed with the most attractive side outward. Our limited warranty does not cover the natural characteristics and blemishes that occur with construction grade lumber products.

Fabricamos nuestros equipos de madera elaborada y de productos maquinados de madera. La madera elaborada, producto de árboles, tiene muchas características e imperfecciones naturales que pueden tener algunas piezas contenidas en el equipo. Estas imperfecciones y características pueden incluir nudos, grano rasgado sobre el borde, rajaduras/grietas pequeñas, torsiones, cortezas en el borde, y bolsos que exuden savia. Aseguramos que hemos cortado e inspeccionado las partes individuales para eliminar las características naturales menos atractivas posibles. Estas características y/o imperfecciones no afectarán la fuerza, durabilidad ni la integridad estructural del producto final. Por lo general, las piezas de moldura exterior seleccionadas para su equipo se elaboran de un solo lado y deben ser instaladas con la parte más atractiva por fuera. Nuestra garantía limitada no cubre las características e imperfecciones que ocurren con los productos de madera elaborada.

(This page intentionally left blank.)

(Esta página está intencionado en blanco.)

## - BEFORE YOU BEGIN -

## - ANTES DE EMPEZAR -

### First...

- Check with your local building authority before erecting.
- Read instructions thoroughly before you begin.

### Building Codes

- Our buildings are designed to meet most local and national U.S. codes and are not meant to be used for living space.
- General construction drawings can be provided.

### Check All Parts

- If a part is missing, circle the part in question and call.
- Please note the primer color may vary on siding and trim parts. This is a factory applied primer intended for preparing your building for painting. This is NOT a finish coat. This primer color variation will not affect the look of your building once painted.

### Important

- Lumber is graded from one side, use most attractive face to the outside.
- In a drawing, a dotted line represents a part hidden from view (like a part under a panel).

### Assistance required

- Assistance is necessary to handle, fit, and secure some components.

### Squareness is very Important!

- Keep 90° corners and 90° perpendiculars throughout the assembly to ensure all components fit together.

### Check foundation size

- Before starting on your foundation, make sure you are building the correct size foundation for your building.

### Safety!

- Check for protruding nails, pound any protruding nails into the wood or cut them off flush.

**Always wear OSHA-APPROVED safety glasses throughout assembly process.**

### Primero...

- Consulte la autoridad de construcción local antes de construir el edificio.
- Lea las instrucciones completamente antes de empezar.

### Códigos de Construcción

- Hemos diseñado nuestros edificios a que conformen con todos los códigos de construcción locales y nacionales. Los edificios no están proyectados como residencia.
- Se disponen planes generales de construcción.

### Compruebe todas las piezas

- Si falta una pieza, indícala con un círculo y llámenos.
- Aviso: El color del imprimador puede variar en la cobertura y las partes de la moldura. Este imprimador se aplica en la fábrica y es para preparar su edificio para pintar. NO es una capa de pintura terminada. La variación en el color del imprimador no afectará la apariencia de su edificio al pintarlo.

### Importante

- La Madera está elaborada en un solo lado. Use el lado más atractivo en el exterior.
- Si falta una pieza, póngale un círculo y llámenos.
- En un dibujo una línea punteada representa una pieza no vista (por ejemplo, una pieza debajo de un panel).

### Ayuda requerido

- Seleccione un sitio nivelado.
- Será necesario pedir ayuda para manejar, unir, y reforzar algunas piezas.

### ¡Es preciso escuadrar el edificio!

- Mantenga ángulos de 90° en las esquinas y los perpendiculars durante la construcción para asegurar que todas las piezas se unen correctamente.

### Comprueba las dimensiones de la cimentación.

- Compruebe que las dimensiones de la cimentación son las correctas para el edificio.

### ¡Seguridad!

- Inspeccione para clavos sobresalientes; hínque cualquier clavo sobresaliente en la madera o córtelo nivelados con la madera.

**Siempre lleve gafas de seguridad aprobadas por OSHA durante la construcción.**

# WOOD SIZE CONVERSION CHART

## CUADRO DE CONVERSIÓN DE TAMAÑO DE LA MADERA

Nominal Board Size	2" x 4" .....1-1/2" x 3-1/2" (3,8 x 8,9 cm)	Actual Size
	1" x 4" .....3/4" x 3-1/2" (1,9 x 8,9 cm)	
Tamaño nominal de la tabla	2" x 3" .....1-1/2" x 2-1/2" (3,8 x 6,3 cm)	Tamaño real
	1" x 3" .....3/4" x 2-1/2" (3,8 x 6,3 cm)	

### NOTE

Double and Triple Letter Part identification letters are stamped on part and read horizontally, single letter part letters not stamped on parts.

### NOTA

Dos letras o tres letras de identificación están marcadas horizontalmente en las piezas. Letras de identificación de una sola letra no están en las piezas.

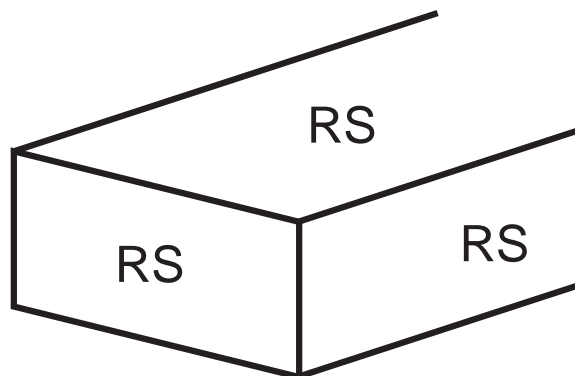









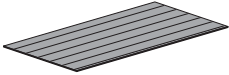
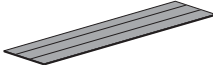
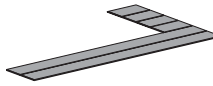
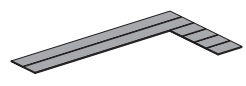
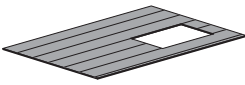







**12' x 10'**  
**PARTS LIST**

**366 x 305 cm**  
**LISTA DE PIEZAS**



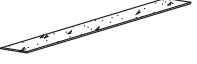
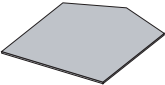
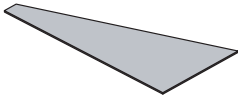
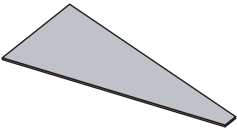







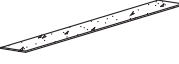







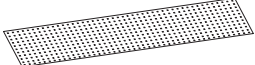
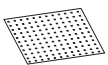
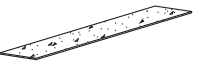

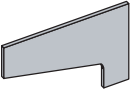

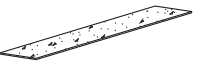

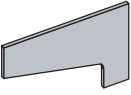



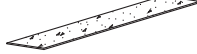

**PAREDES**

**WALLS**

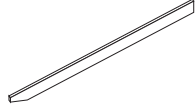
<p>48 x 84" (122 x 213 cm)</p>  <p><b>A</b> x7</p>	<p>23-7/8 x 84" (60,6 x 213 cm)</p>  <p><b>B</b> x2</p>	<p>48 x 84" (122 x 213 cm)</p>  <p><b>C</b> x1</p>	<p>48 x 84" (122 x 213 cm)</p>  <p><b>D</b> x1</p>
<p>48 x 84" (122 x 213 cm)</p>  <p><b>E</b> x1</p>	<p>2 x 4 x 96" (5 x 10 x 244 cm)</p>  <p><b>TP</b> x6</p>	<p>2 x 4 x 24" (5 x 10 x 61 cm)</p>  <p><b>RL</b> x4</p>	<p>2 x 4 x 92-1/2" (5 x 10 x 235 cm)</p>  <p><b>TJ</b> x5</p>
<p>2 x 4 x 44-1/2" (5 x 10 x 113 cm)</p>  <p><b>STL</b> x3</p>	<p>2 x 4 x 48" (5 x 10 x 122 cm)</p>  <p><b>SP</b> x2</p>	<p>2 x 4 x 20-1/2" (5 x 10 x 52 cm)</p>  <p><b>RP</b> x2</p>	<p>2 x 4 x 78-1/2" (5 x 10 x 199 cm)</p>  <p><b>AI</b> x22</p>
<p>2 x 4 x 68" (5 x 10 x 173 cm)</p>  <p><b>UM</b> x2</p>	<p>2 x 4 x 7" (5 x 10 x 18 cm)</p>  <p><b>AL</b> x5</p>	<p>2 x 4 x 67" (5 x 10 x 170 cm)</p>  <p><b>AM</b> x2</p>	<p>2 x 4 x 22-1/2" (5 x 10 x 57 cm)</p>  <p><b>AO</b> x3</p>
<p>2 x 4 x 11-5/8" (5 x 10 x 29,5 cm)</p>  <p><b>BG</b> x1</p>	<p>2 x 4 x 38" (5 x 10 x 113 cm)</p>  <p><b>SJ</b> x1</p>	<p>2 x 4 x 18-1/8" (5 x 10 x 40 cm)</p>  <p><b>AF</b> x4</p>	<p>7/16 x 3 x 66" (1,1 x 7,6 x 168 cm)</p>  <p><b>F</b> x1</p>
<p>23-7/8 x 28-1/2" (61 x 73 cm)</p>  <p><b>G</b> x2</p>	<p>23-9/16 x 48" (60 x 122 cm)</p>  <p><b>G-1</b> x2</p>	<p>23-9/16 x 48" (60 x 122 cm)</p>  <p><b>G-2</b> x2</p>	<p>2 x 4 x 60-1/2" (5 x 10 x 154 cm)</p>  <p><b>AV</b> x1</p> <hr/> <p>2 x 4 x 12-1/2" (5 x 10 x 32 cm)</p>  <p><b>AJ</b> x1</p>

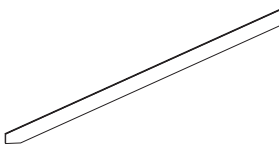
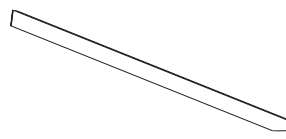
**12' x 10'**  
**PARTS LIST**

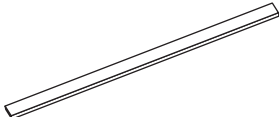
**366 x 305 cm**  
**LISTA DE PIEZAS**

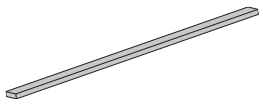
<b>ESTANTES</b>	<p>7/16 x 11-1/2 x 96" (1,1x 30 x 244 cm)</p>  <p><b>S-1</b> x1</p>	<p>7/16 x 11-1/2 x 23-7/8" (1,1 x 30 x 40 cm)</p>  <p><b>S-2</b> x1</p>	<p>1 x 4 x 96" (2,5 x 10 x 244 cm)</p>  <p><b>KP</b> x2</p>	<p>1 x 4 x 24" (2,5 x 7,6 x 61 cm)</p>  <p><b>JS</b> x1</p>	<p>1 x 3 x 96" (2,5 x 7,6 x 244 cm)</p>  <p><b>BE</b> x1</p>
	<p>1 x 3 x 24" (2,5 x 7,6 x 61 cm)</p>  <p><b>BC</b> x1</p>	<p>1 x 4 x 20-1/2" (2,5 x 7,6 x 52 cm)</p>  <p><b>BA</b> x1</p>	<p>2 x 3 x 10" (5 x 7,6 x 25 cm)</p>  <p><b>AC</b> x6</p>	<p>23-7/8 x 96" (61 x 244 cm)</p>  <p><b>P-1</b> x1</p>	<p>23-7/8 x 23-7/8" (61 x 61 cm)</p>  <p><b>P-2</b> x1</p>
	<p>7/16 x 19-1/2 x 92-1/2" (1,1x 49,5 x 235 cm)</p>  <p><b>B-1</b> x1</p>	<p>7/16 x 19-1/2 x 23-7/8" (1,1 x 49,5 x 60,6 cm)</p>  <p><b>B-2</b> x1</p>	<p>2 x 3 x 19" (5 x 7,6 x 48 cm)</p>  <p><b>LR</b> x6</p>	<p>3/8 x 14-1/4 x 22-1/4" (36 x 56,5 cm)</p>  <p><b>B-3</b> x5</p>	<p>2-1/2 x 12" (6,3 x 30,5 cm)</p>  <p><b>J-2</b> x6</p>
	<p>7/16 x 19-1/2 x 92-1/2" (1,1x 49,5 x 235 cm)</p>  <p><b>B-1</b> x1</p>	<p>7/16 x 19-1/2 x 23-7/8" (1,1 x 49,5 x 60,6 cm)</p>  <p><b>B-2</b> x1</p>	<p>2 x 3 x 19" (5 x 7,6 x 48 cm)</p>  <p><b>LR</b> x6</p>	<p>3/8 x 14-1/4 x 22-1/4" (36 x 56,5 cm)</p>  <p><b>B-3</b> x5</p>	<p>2 x 3 x 30-3/8" (5 x 7,6 x 77 cm)</p>  <p><b>CQ</b> x3</p>
	<p>7/16 x 36 x 96" (1,1x 91,4 x 244 cm)</p>  <p><b>L-1</b> x1</p>	<p>7/16 x 15-7/8 x 36" (1,1 x 40 x 91,4 cm)</p>  <p><b>L-2</b> x1</p>	<p>2 x 4 x 96" (5 x 10 x 244 cm)</p>  <p><b>TP</b> x2</p>	<p>2 x 4 x 24" (5 x 10 x 61 cm)</p>  <p><b>RL</b> x2</p>	<p>2 x 3 x 96" (5 x 7,6 x 244 cm)</p>  <p><b>PT</b> x1</p>
<p>7/16 x 48 x 96" (1,1 x 122 x 244 cm)</p>  <p><b>J</b> x2</p>	<p>7/16 x 47-7/8 x 48" (1,1 x 121,6 x 122 cm)</p>  <p><b>K</b> x2</p>	<p>7/16 x 23-1/8 x 96" (1,1x 59 x 244 cm)</p>  <p><b>L</b> x2</p>	<p>7/16 x 23-1/8 x 48" (1,1 x 59 x 122 cm)</p>  <p><b>M</b> x2</p>	<p>Rafter Viga 2 x 4 x 65-1/2" (5 x 10 x 166 cm)</p>  <p><b>AD</b> x14</p>	<p>Gusset Placa de Unión 6 x 24" (15 x 61 cm)</p>  <p><b>U</b> x12</p>
<p>5/8 x 4 x 72-1/4" (1,6 x 10 x 183,5 cm)</p>  <p><b>AJL</b> x2</p>	<p>5/8 x 4 x 72-1/4" (1,6 x 10 x 183,5 cm)</p>  <p><b>AJR</b> x2</p>	<p>2 x 4 x 72" (5 x 10 x 183 cm)</p>  <p><b>TM</b> x1</p>			
<p>2 x 6 x 49-1/2" (5 x 15 x 126 cm)</p>  <p><b>AS</b> x2</p>	<p>2 x 6 x 96" (5 x 15 x 244 cm)</p>  <p><b>VX</b> x2</p>	<p>2 x 2 x 84" (5 x 5 x 213 cm)</p>  <p><b>S</b> x4</p>	<p>1 x 3 x 72" (2,5 x 7,6 x 183 cm)</p>  <p><b>HJ</b> x1</p>		





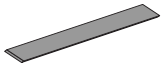
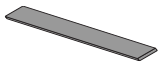
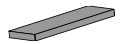
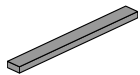
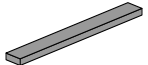
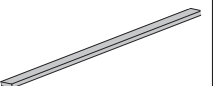

**12' x 10'  
PARTS LIST**

**366 x 305 cm  
LISTA DE PIEZAS**

TRIM | MOLDURA

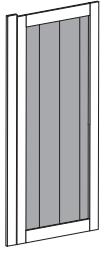
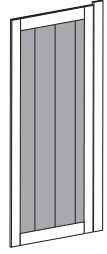
<p>5/8 x 3 x 21" (1,6 x 7,6 x 53 cm)</p>  <p><b>BWL</b> x1</p>	<p>5/8 x 3 x 21" (1,6 x 7,6 x 53 cm)</p>  <p><b>BWR</b> x1</p>	<p>5/8 x 3 x 8-1/2" (1,6 x 7,6 x 21,6 cm)</p>  <p><b>DF</b> x4</p>	<p>5/8 x 3 x 28-1/8" (1,6 x 7,6 x 71,4 cm)</p>  <p><b>DT</b> x2</p>	<p>5/8 x 3 x 30-1/8" (1,6 x 7,6 x 76,5 cm)</p>  <p><b>AZ</b> x6</p>	<p>2 x 3 x 68-1/4" (5 x 7,6 x 173 cm)</p>  <p><b>OO</b> x2</p>
---	---	---	---	--	---

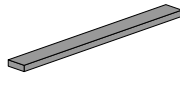
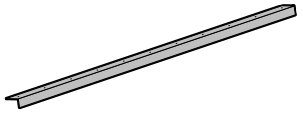

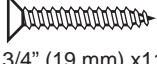



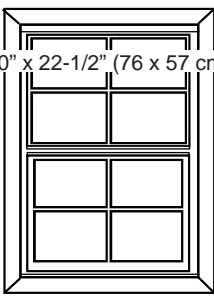
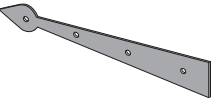
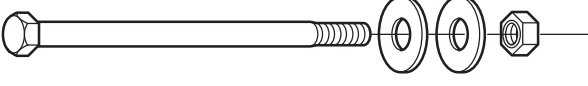
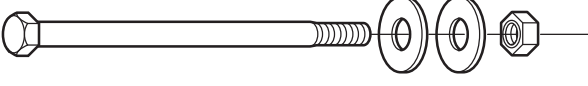

DOOR | PUERTA

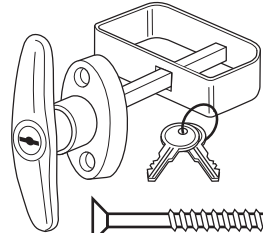
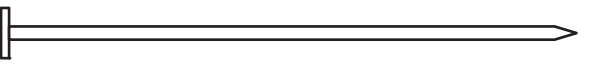
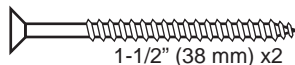
<p>Left Door Puerta izquierda</p>  <p><b>V</b> x1</p>	<p>Right Door Puerta derecha</p>  <p><b>W</b> x1</p>	<p>1 x 3 x 62" (2,5 x 7,6 x 157,5 cm)</p>  <p><b>AHR</b> x1</p>	<p>1 x 3 x 26-5/8" (2,5 x 7,6 x 68 cm)</p>  <p><b>AH</b> x2</p>	<p>64" Metal Threshold Entrada de Metal 162,5 cm</p>  <p><b>Y</b> x1</p>
		<p>1 x 3 x 62" (2,5 x 7,6 x 157,5 cm)</p>  <p><b>AHL</b> x1</p>		<p>3/4" (19 mm) x11</p> 

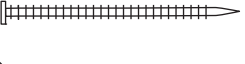
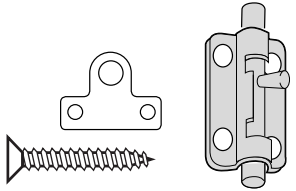
FERRETERÍA

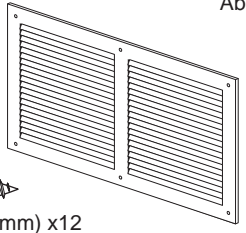
<p>Window Ventana</p> <p>30" x 22-1/2" (76 x 57 cm)</p>  <p>x1</p>	<p>Hinge (Bisagra)</p>  <p><b>Z</b> x4</p>	<p>3/8" SHELF HDW. SET: 5-1/2" Hex bolt, 2 flat washers, lock nut</p> 	<p>HDW. SISTEMA de la ESTANTE 9,5 mm: Pemo del hexágono 14 cm, dos arandelas planas, tuerca de fijación</p> <p>Not to scale. Tamaño no real.</p>  <p>x1</p>
--	--	--	---

HARDWARE

	Actual Size	Dimensiones Verdadera	
 <p>x1</p>	3" (7,6 cm)		x 368
 <p>1-1/2" (38 mm) x2</p>	2" (5,0 cm)		x 1230
	2" (5,0 cm)		x 23
	1-1/4" (32 mm)		x 64
 <p>3/4" (19 mm) x6</p> <p>x2</p>	3" (7,6 cm) ⊕		x 34
	2" (5,0 cm) ⊕		x 10
<p>Vent Abertura</p>  <p>1/2" (13 mm) x12</p> <p>x2</p>	1-1/4" (32 mm) ⊕		x 80
	1" (25 mm) ⊕		x 40
	3/4" (19 mm) ⊕		x 46

# IMPORTANT!

## Building Tip

FOR THE BEST LOOKING FINISHED PRODUCT WE RECOMMEND THAT YOU INSPECT, SORT AND LAY OUT MATERIALS PRIOR TO BEGINNING ASSEMBLY OF YOUR BUILDING.

# ¡IMPORTANTE!!!

## Consejo

CON EL FIN DE OBTENER EL PRODUCTO ACABADO DE MEJOR ASPECTO RECOMENDAMOS QUE INSPECCIONE, CLASIFIQUE Y ORGANICE LOS MATERIALES ANTES DE EMPEZAR A MONTAR SU EDIFICIO.

## HELPFUL MATERIAL NOTICE

## AVISO ÚTIL SOBRE LOS MATERIALES

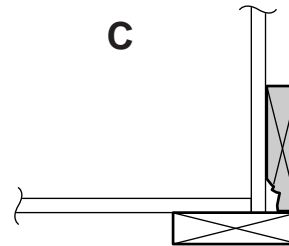
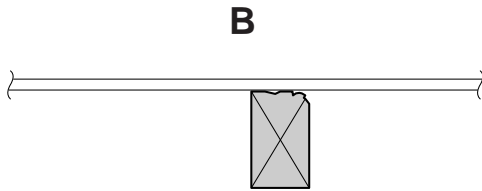
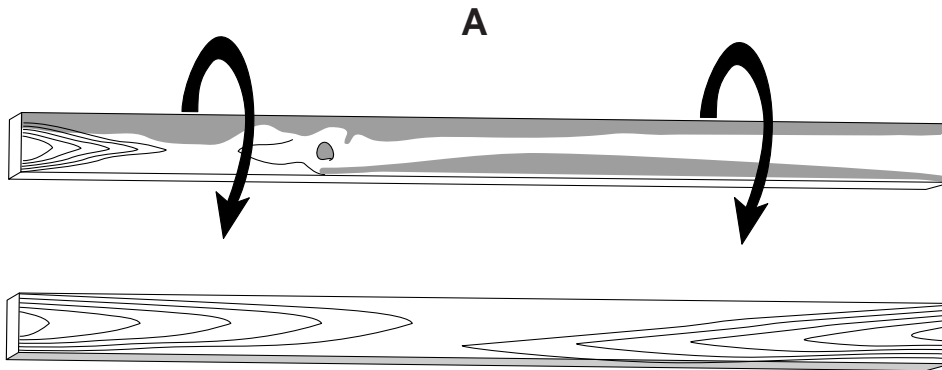

Wood is a natural product that has inherent blemishes. All interior framing is graded for structural strength and not appearance. Exterior trim is graded for one good side per industry standards.

- Blemishes can be easily installed to provide the best appearance. (Fig. A)
- Install wall framing with any blemished sides toward the siding and facing rear of building. (Fig. B)
- Install corner trim, gable trim and fascia with any blemished sides toward the siding material. (Fig. C)

Always install the material leaving the best edge and best surface visible.

Please remember that these blemishes in no way negatively affect the strength or integrity of our product.

La madera es un producto natural que tiene defectos inherentes. Todo la estructura interior ha sido aprobada por ofrecer una resistencia estructural y no por su aspecto. La guarnición exterior ha sido aprobada por tener un buen lado según las normas de la industria.

- La parte con defectos puede instalarse fácilmente de modo que el edificio tenga el mejor aspecto. (Fig. A)
- Instale el entramado de la pared con los lados con defectos apuntando hacia los costados y haciendo frente a la parte trasera del edificio. (Fig. B)
- Instale la guarnición de las esquinas, la guarnición de los hastiales y las impostas con los lados con defectos apuntando hacia el material lateral. (Fig. C)

Instale siempre el material dejando visibles el mejor borde y la mejor superficie.

Recuerde que estos defectos no afectan de forma negativa la resistencia o la integridad de nuestros productos.

Please feel free to call our Consumer Help Line - Toll Free  
**1-888-827-9056**

April through October M - F 8:00 AM to 7:00 PM EST

Saturday 8:30 AM to 4:30 PM EST

November through March M - F 8:00 AM to 5:00 PM EST

Llame de forma gratuita a nuestra línea de ayuda al consumidor

**1-888-827-9056**

Abril por octubre M - F 8:00 EST a 7:00 P.M. EST

el sábado 8:30 EST a 4:30 P.M. EST

noviembre por marzo M - F 8:00 EST a 5:00 P.M. EST

# IMPORTANT!

## Building Tip

YOU MAY NEED TO RACK YOUR WALL PANELS AND ROOF PANELS TO ENSURE SQUARENESS BEFORE COMPLETELY NAILING.

# ¡IMPORTANTE!

## Consejo

ES PRECISO ALINEAR LOS PANELES DE LOS MUR-OS Y DEL TECHO ANTES DE CLAVARLOS COMPLETAMENTE PARA ASEGURAR LA ESCUADRA.

### Racking a Wall

**THIS PAGE SHOWS EXAMPLES:**  
This may not be how your shed walls are built. Refer to pages showing wall assembly.

### Alineando un Muro

**ESTA PÁGINA DEMUESTRA EJEMPLOS:**  
Éste puede no ser cómo se construyen las paredes. Refiera a las páginas reales que demuestran el montaje de la pared.

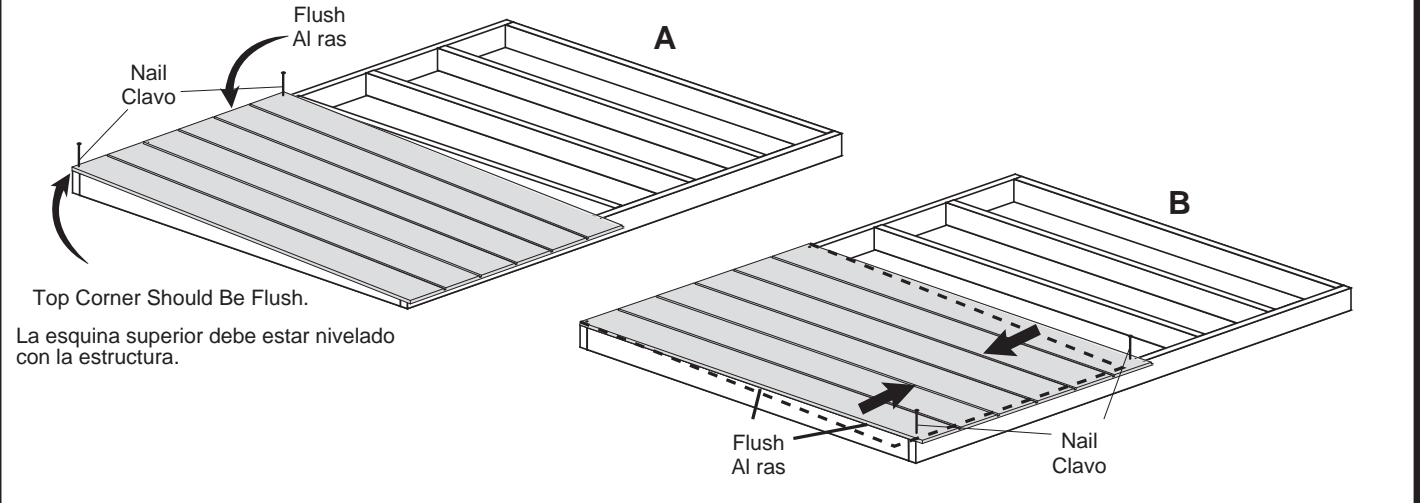

When building walls, always apply panel at far left first. Position panel flush with top of wall frame and nail in upper corners as shown. Rack wall square by moving lower end of wall panel right or left until panel is flush with framing along left edge and secure with one nail in each lower corner. Continue nailing as instructed.

Al construir los muros, siempre fije primero el panel hasta la izquierda extrema. Posicione el panel nivelado con la parte superior de la estructura del muro y clávelo en la esquina superior como en el dibujo. Alinee nivelado el muro por mover el lado inferior a la derecha o a la izquierda hasta que el panel esté nivelado con la estructura a lo largo del borde izquierda. Fije con un clavo en cada esquina inferior.

### Racking a Roof

### Alineando un techo

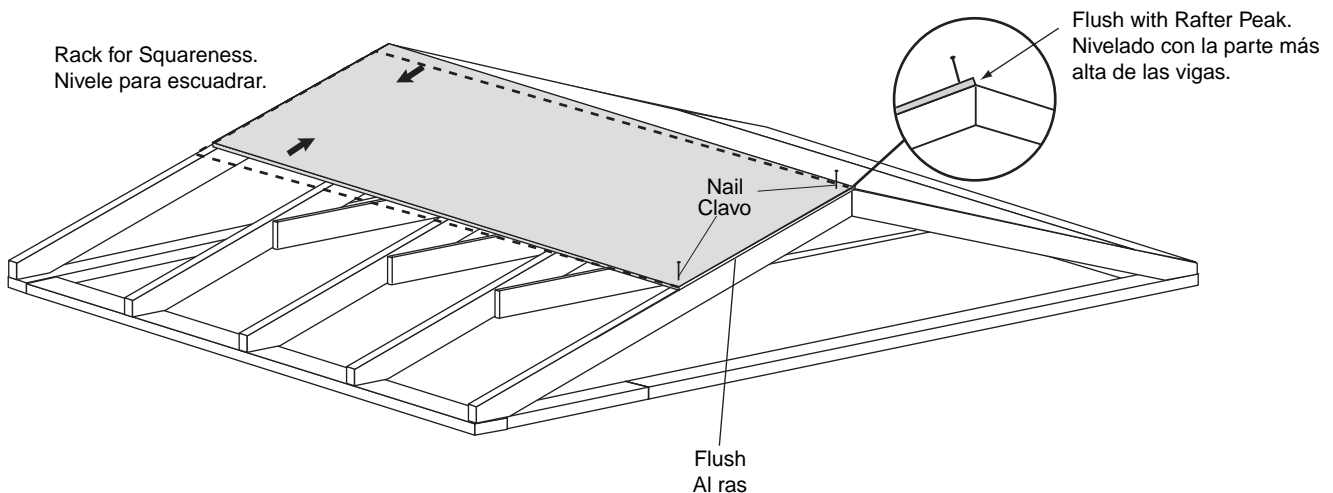

Position panel flush with outside front edge of rafter and nail in two corners as shown. Rack panel square by moving opposite end up or down until panel is flush along peak of rafters and secure with one nail in each corner. Ensure spacing of center rafters and nail as instructed.

Posicione los paneles nivelados con el borde delantero exterior de la viga y clave en las dos esquinas como en el dibujo. Alinee escuadra el panel por mover los extremos opuestos arriba o abajo hasta que el panel esté nivelado a lo largo del punto más alto de las vigas, y fíjelo con un clavo en cada esquina. Compruebe el espacio de las vigas centrales y clave como indicado.

## FOUNDATION OPTIONS

(Material Not Supplied With Kit)  
IF YOU ASSEMBLE YOUR BUILDING ON A  
CONCRETE SLAB FOLLOW THESE SPECS.

### SITE PREPARATION

- Site must be properly leveled.
- Site should have natural drainage and no standing water.

## OPCIONES PARA LA CIMIENTO

(No incluidas)  
SI USTED CONSTRUYE ESTE EDIFICIO EN UNA FUNDACIÓN  
DEL CEMENTO SIGA ESTAS ESPECIFICACIONES.

### PREPARACIÓN DEL SITIO

- El sitio debe de estar nivelado correctamente.
- Instale una barrera contra yerbajos debajo de la estructura.

## Concrete Slab Foundation

## Base en losa de concreto

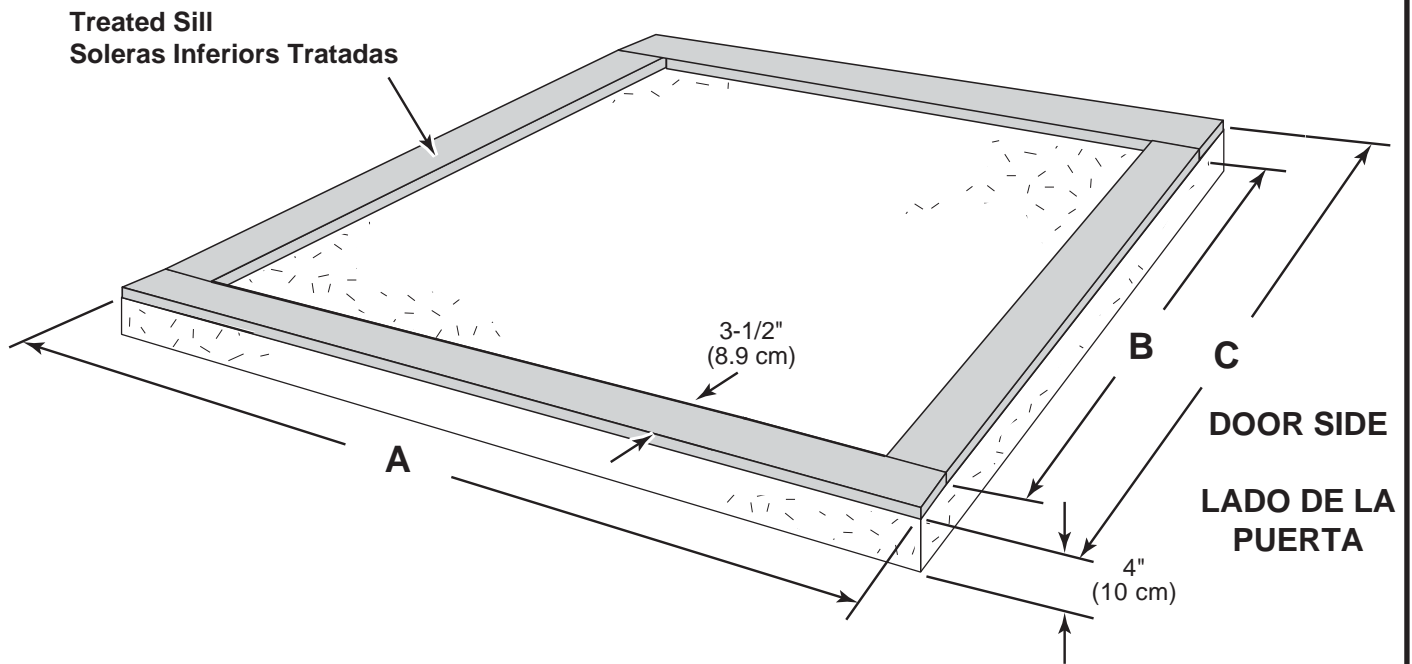

**NOTE:**  
Treated sill-plates are not included in your kit.

**NOTA:**  
Las travesaño-placas tratadas no se incluyen con su kit.

Building Size Dimensiones del edificio	A	B	C
12' x 10' (366 x 305 cm)	120" (305 cm)	137" (348 cm)	144" (366 cm)

Fasten treated 2x4" sill plates to slab using approved concrete anchors. (Treated sill plates and fasteners not included.)

Fije las soleras inferiores tratadas 5x10 cm a la losa con anclajes de concreto aprobados. (Las soleras y los anclajes no están incluidos.)

**NOTE: Your kit's walls may be different from wall shown.**  
**NOTA: Las paredes de su kit pueden ser diferentes de la pared demostrada.**

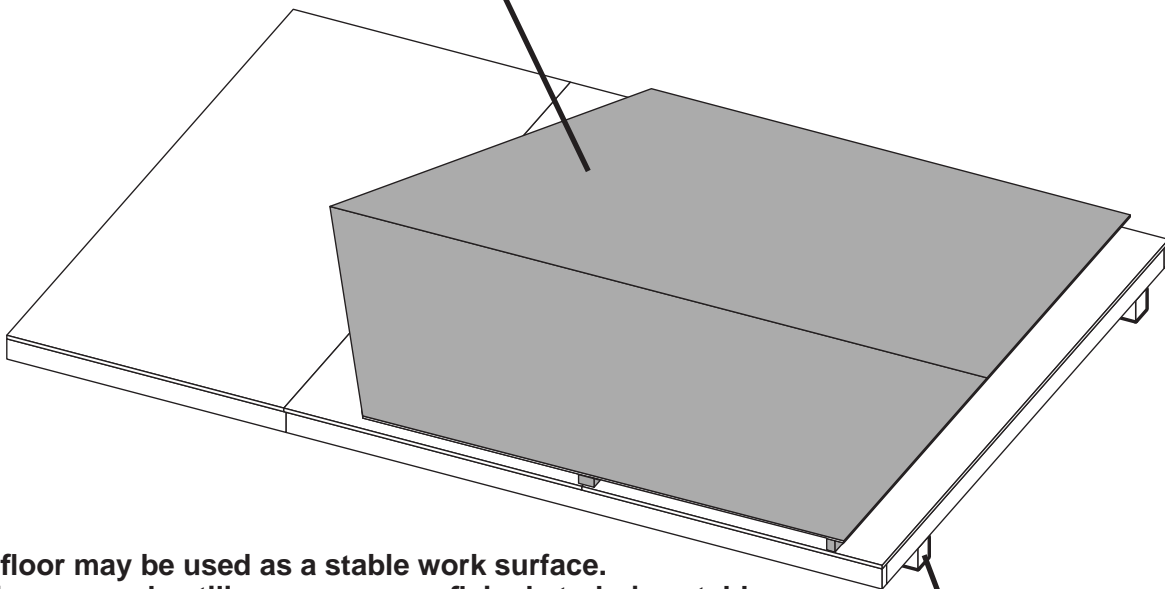

- The floor may be used as a stable work surface.
- El piso se puede utilizar como superficie de trabajo estable.

**NOTE: Supports not included in kit.**  
**NOTA: Vigas de ayuda no incluidas en kit.**

- Organize your assembly procedure during the build process to avoid over-handling of the walls.
- Organice su procedimiento de la asamblea durante e procesode la estructura para evitar la sobre-dirección de las paredes.

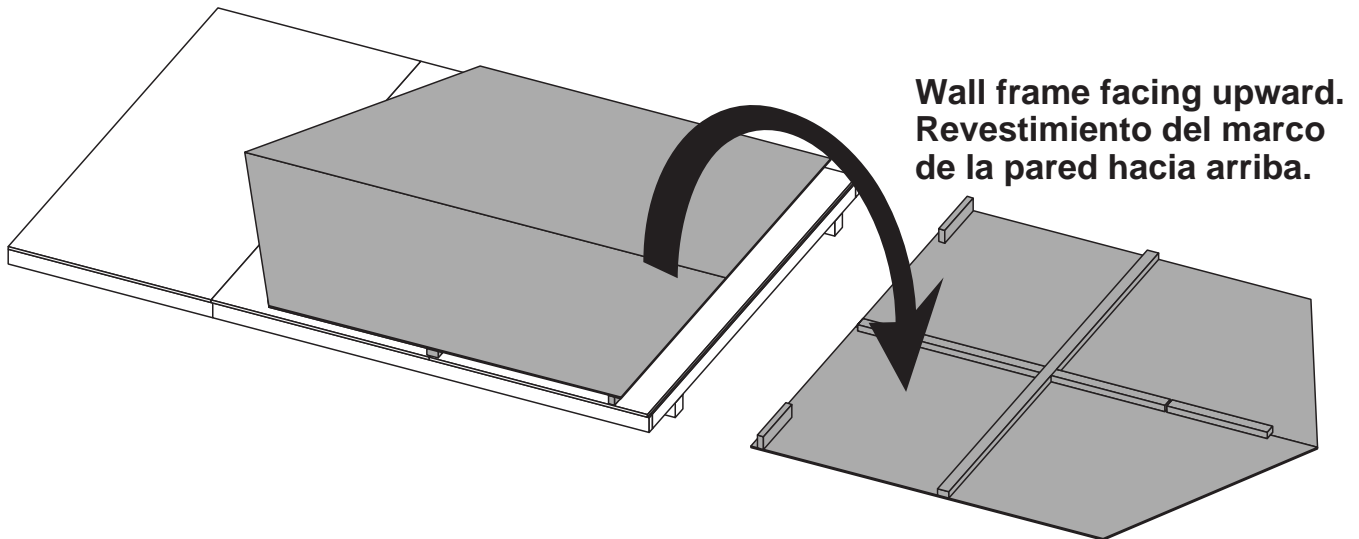

SIDE WALL

3" (7,6 cm)

x 56

PARED LATERAL

**BUILD TWO IDENTICAL WALLS AS SHOWN  
HAGA DOS PAREDES IDÉNTICAS COMO SE MUESTRA**

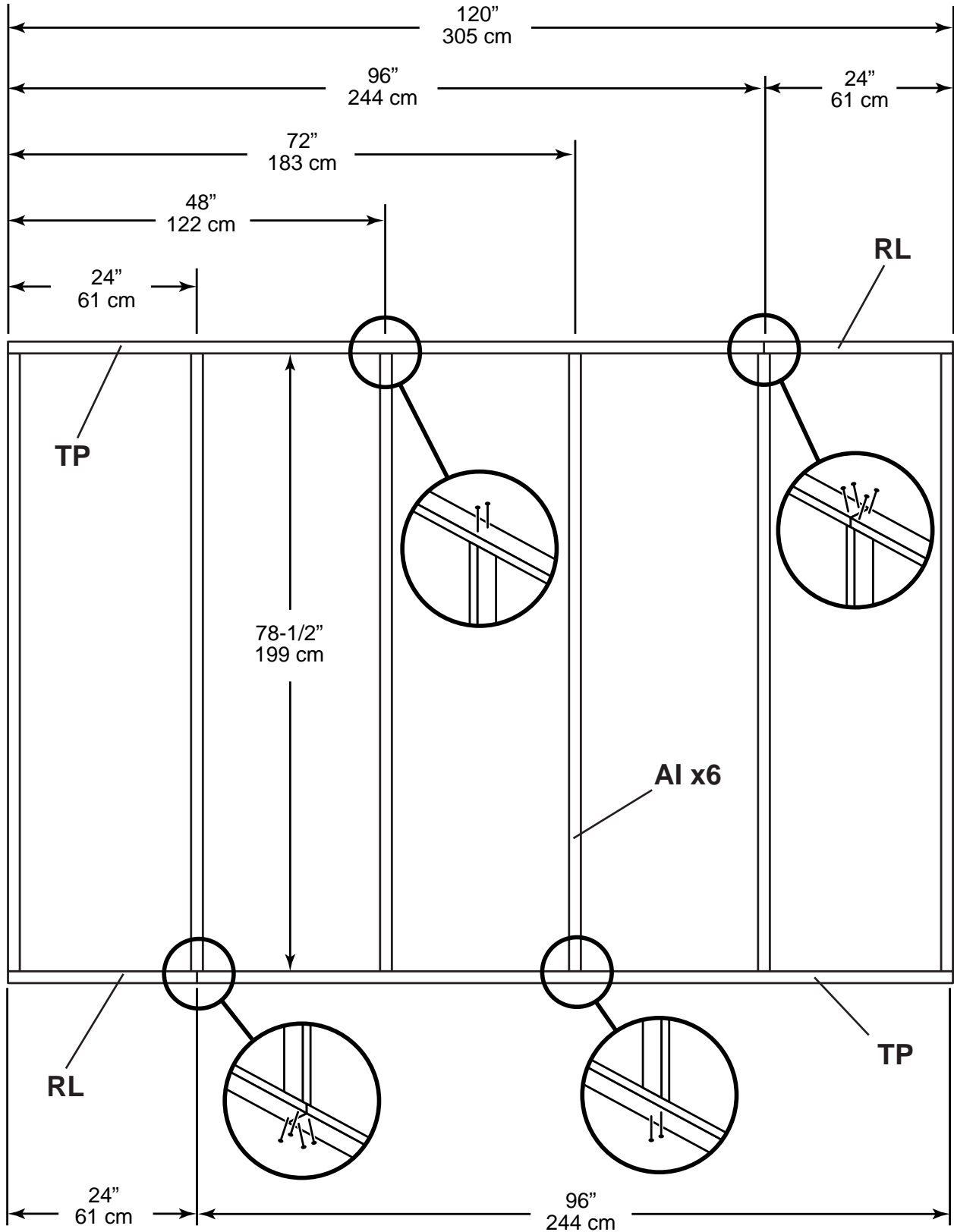

# BACK WALL

# PARED TRASERA

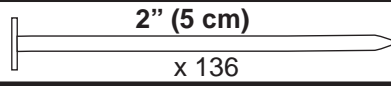

See Page 7 for Building Tip!!!  
¡Ver la página 7 para un consejo!!!

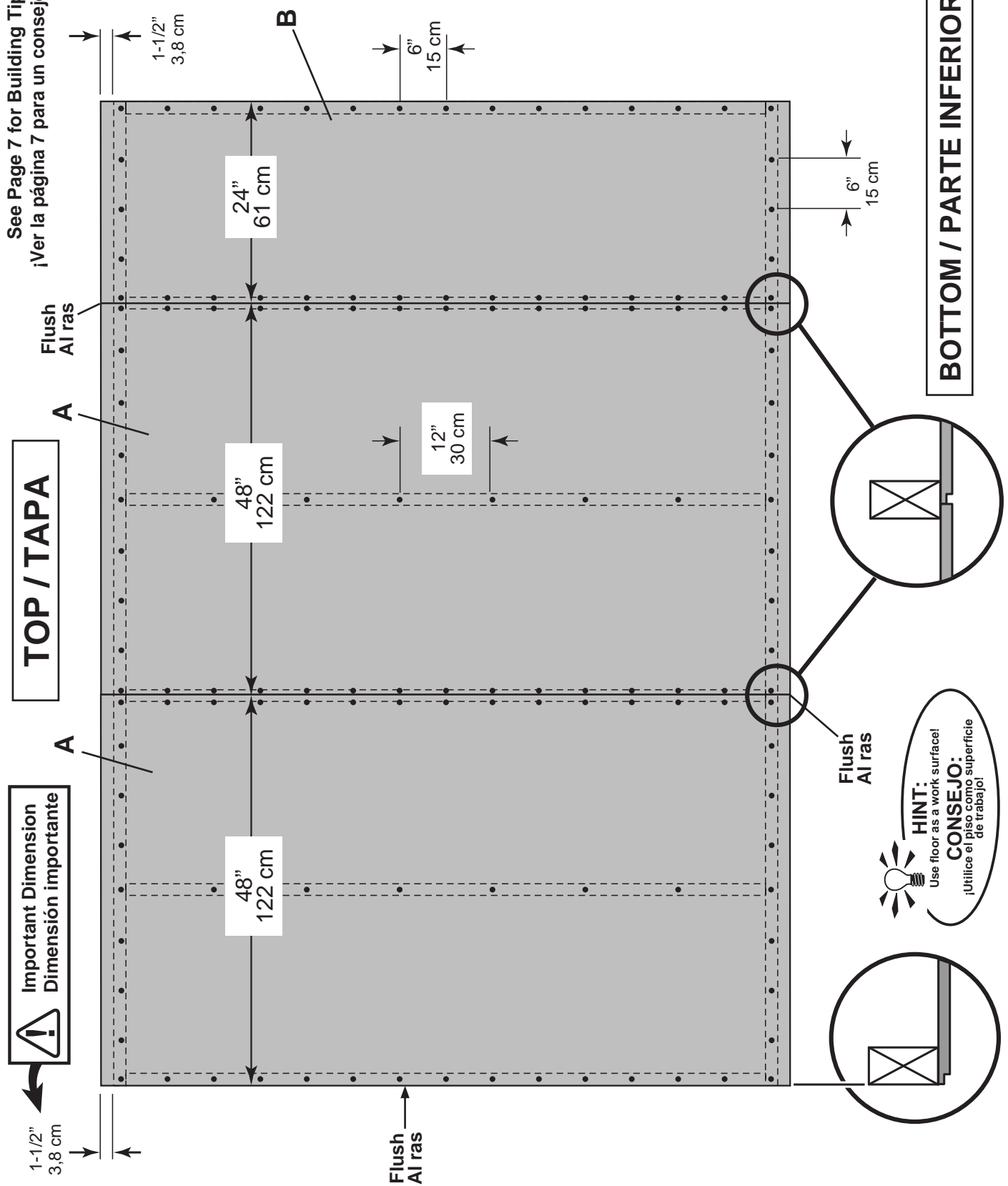

**TOP / TAPA**

**BOTTOM / PARTE INFERIOR**

**Important Dimension**  
Dimensión importante

1-1/2"  
3,8 cm

Flush  
Al ras

A

A

B

Flush  
Al ras

12"  
30 cm

Flush  
Al ras



**HINT:**  
Use floor as a work surface!  
**CONSEJO:**  
¡Utilice el piso como superficie de trabajo!

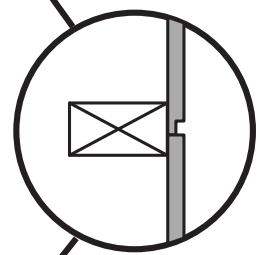
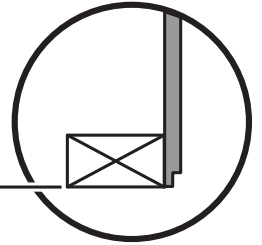

# FRONT WALL

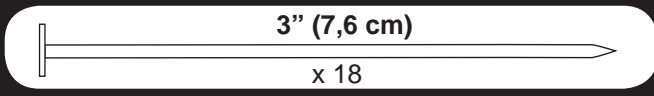

# PARED DELANTERA

Begin the front wall assembly procedure by pre-assembling the door header.

Comience el procedimiento del montaje de la pared delantera premontando el cabezal de puerta.

**1**

Ensure parts AM and F are aligned perfectly on a flat surface. Center F with 1/2" gap at each side. Spread glue across AM and F as shown. Asegúrese que las partes AM y F estén alineadas perfectamente en una superficie plana. Centre F con el boquete de 13 mm en cada lado. Separe el pegamento a través AM y F como se muestra.

TOP VIEW / VISIÓN SUPERIOR

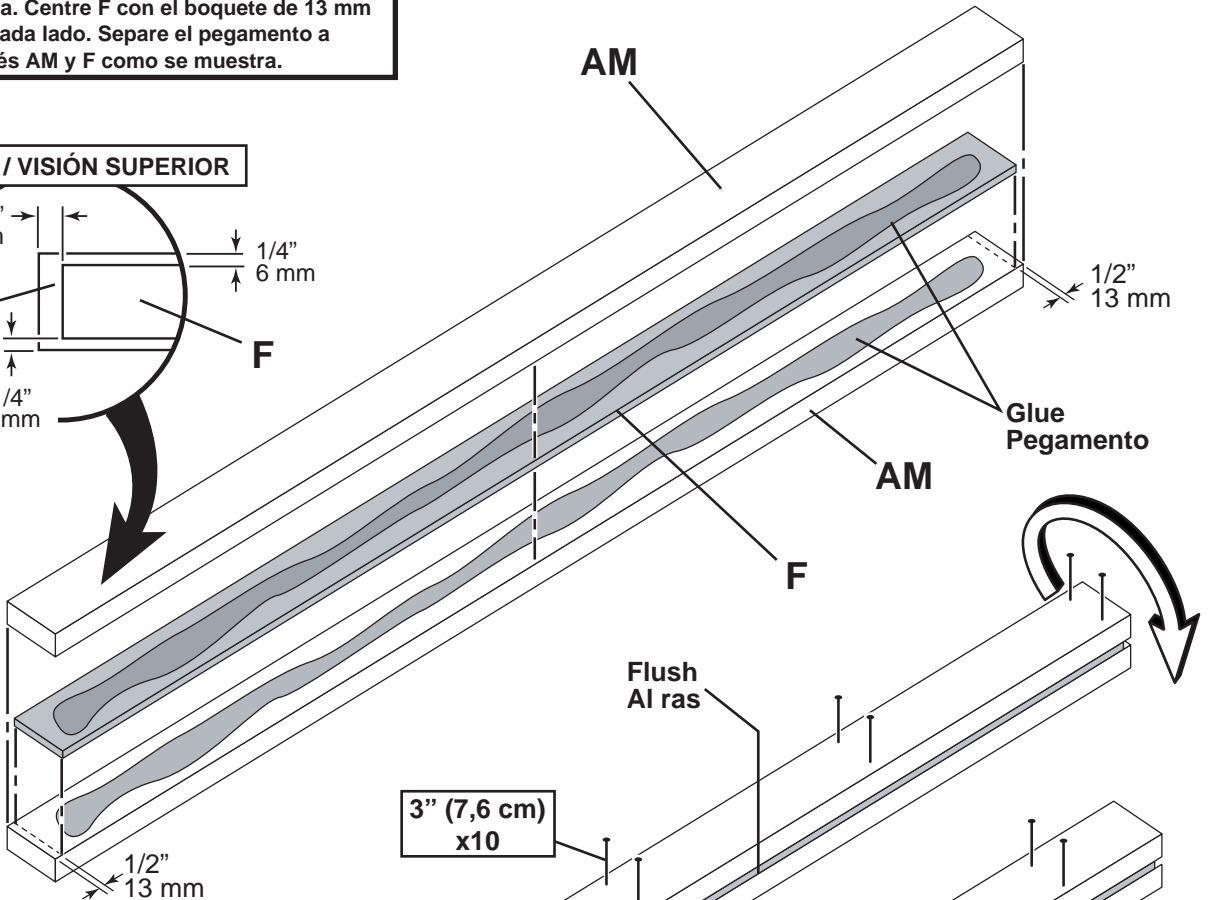
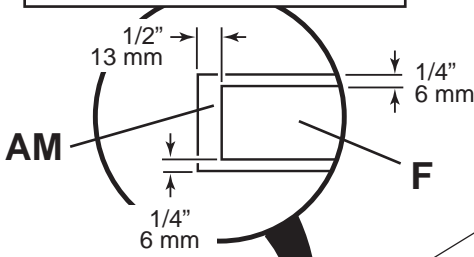

**2**

Assemble header with ten 3" nails as shown. Ensure alignment of parts at the sides. Monte cabezal con diez clavos de los 7,6 cm como se muestra. Asegure la alineación de piezas en los lados.

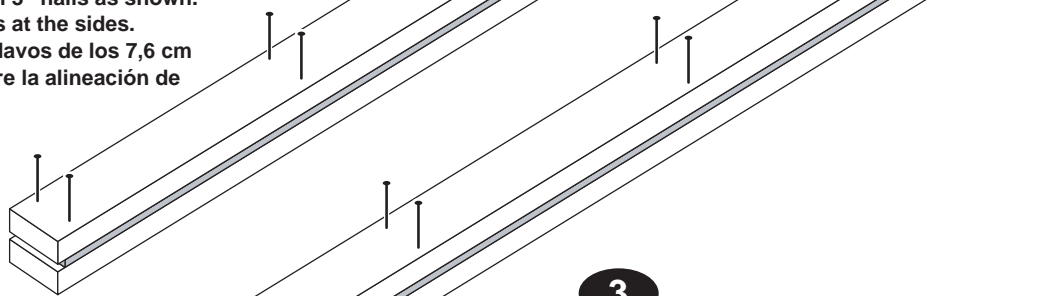

**3**

Turn assembled header over and nail using eight 3" nails as shown. Dé vuelta a excesivo cabezal montada y concluya la enclavación usando ocho clavos de los 7.6cm como se muestra.

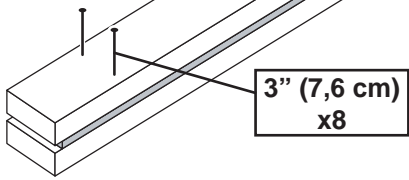



FRONT WALL

3" (7,6 cm)

PARED DELANTERA

x 30

DIMENSIONS ARE TO CENTER OF STUDS.  
LAS DIMENSIONALES ESTÁN AL CENTRO DEL MONTANTES.

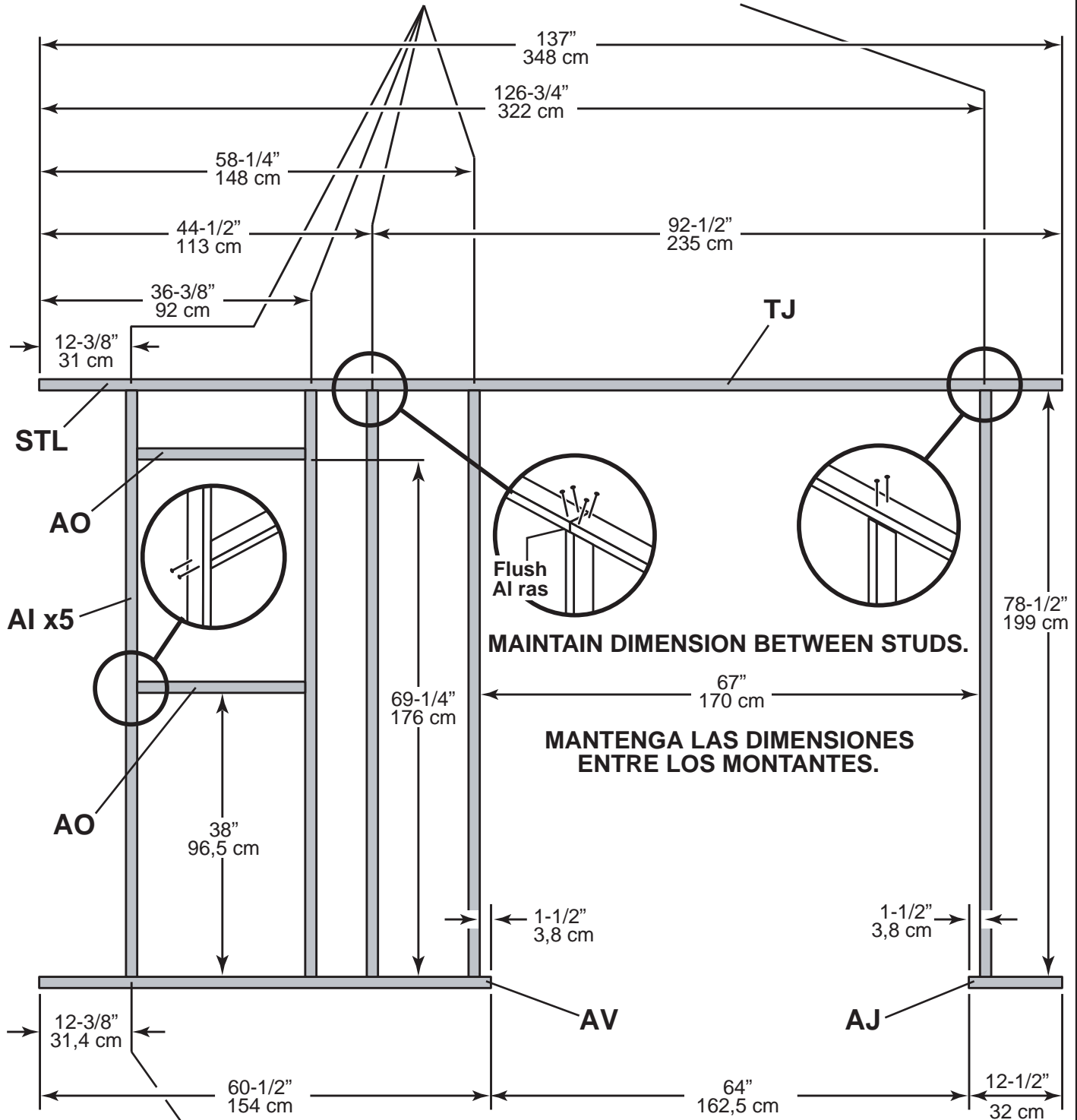

CENTER OF STUD  
CENTRO DEL MONTANTE



**HINT:**  
Use floor as a work surface!  
**CONSEJO:**  
¡Utilice el piso como superficie de trabajo!

**FRONT WALL**

**PARED DELANTERA**

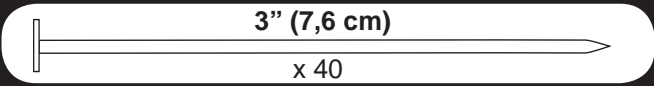

**DIMENSIONS ARE TO CENTER OF STUDS.  
LAS DIMENSIONALES ESTÁN AL CENTRO DEL MONTANTES.**

**Install end part AL first, allowing for more room to swing the hammer.**  
**Instale la pieza AL del extremo primero. El martillo necesitará el espacio de funcionamiento adicional.**

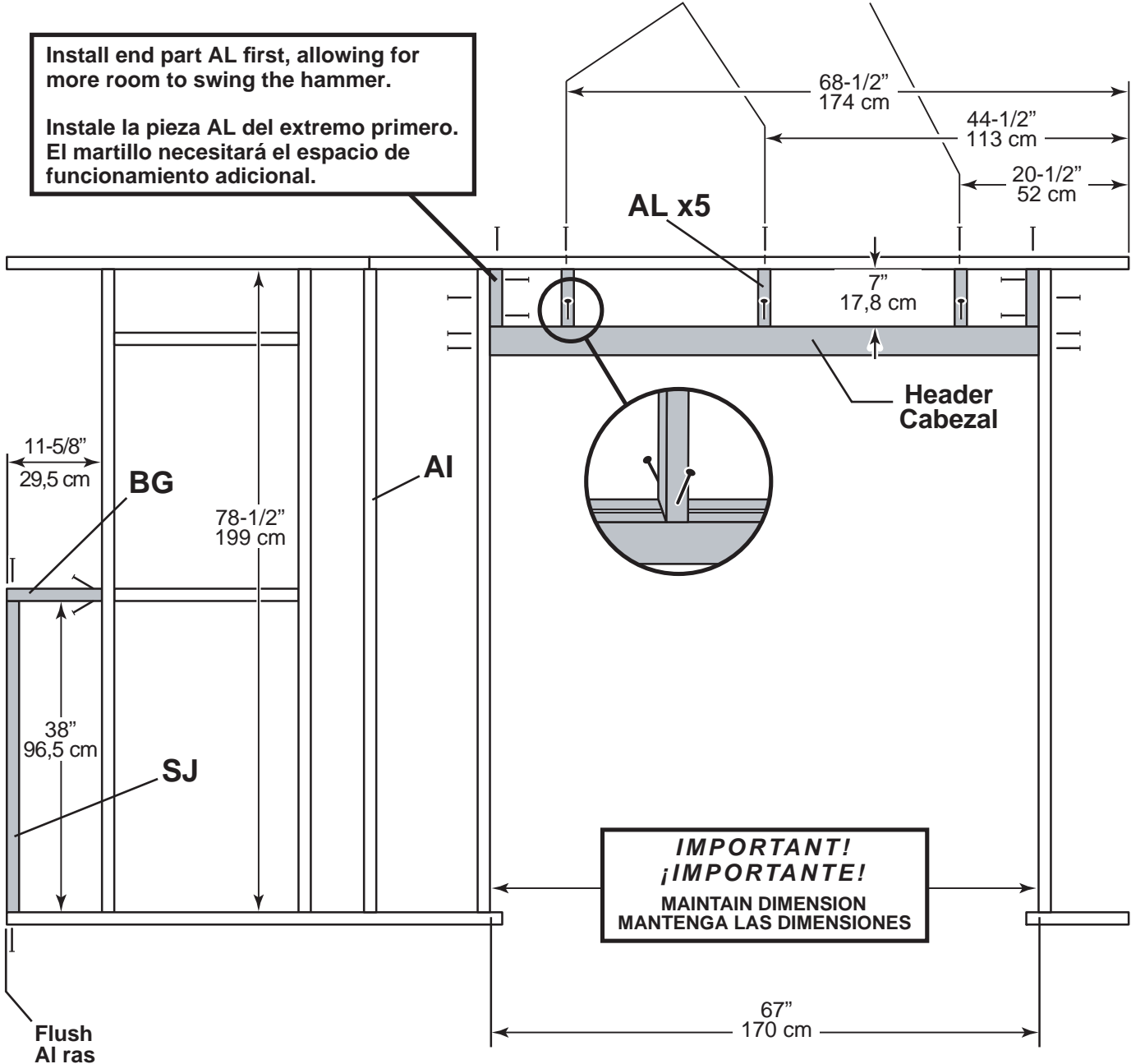

**IMPORTANT!  
¡IMPORTANTE!**  
MAINTAIN DIMENSION  
MANTENGA LAS DIMENSIONES

**HINT:**  
Use floor as a work surface!  
**CONSEJO:**  
¡Utilice el piso como superficie de trabajo!

FRONT WALL

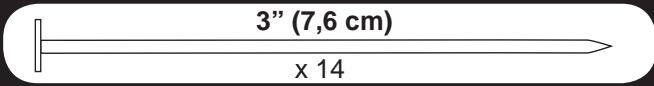

PARED DELANTERA

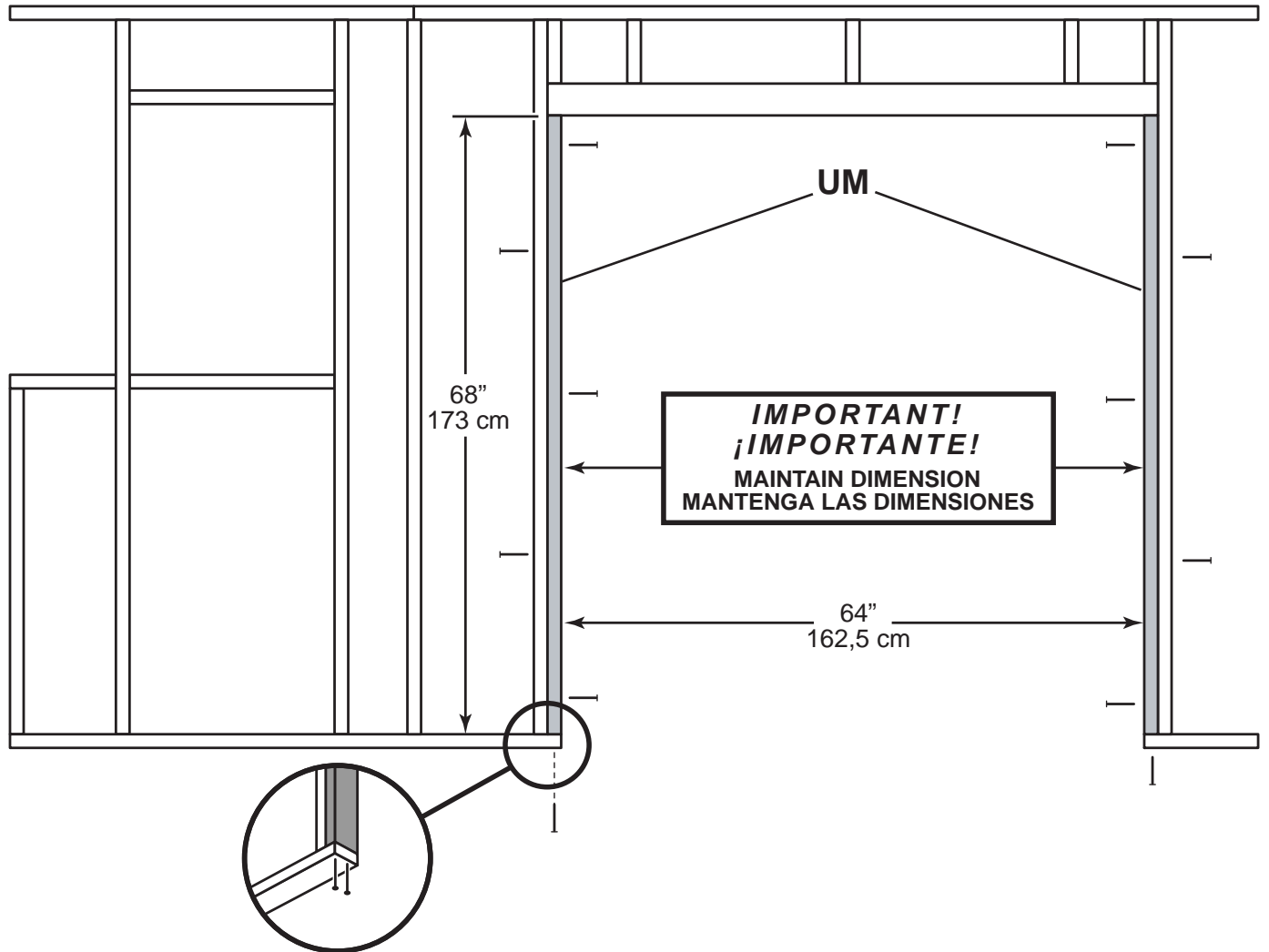

**HINT:**  
Use floor as a work surface!

**CONSEJO:**  
¡Utilice el piso como superficie de trabajo!

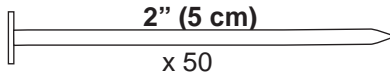

**Important Dimension**  
Dimensión importante

See Page 8 for Building Tip!  
¡Ver la página 8 para un consejo!

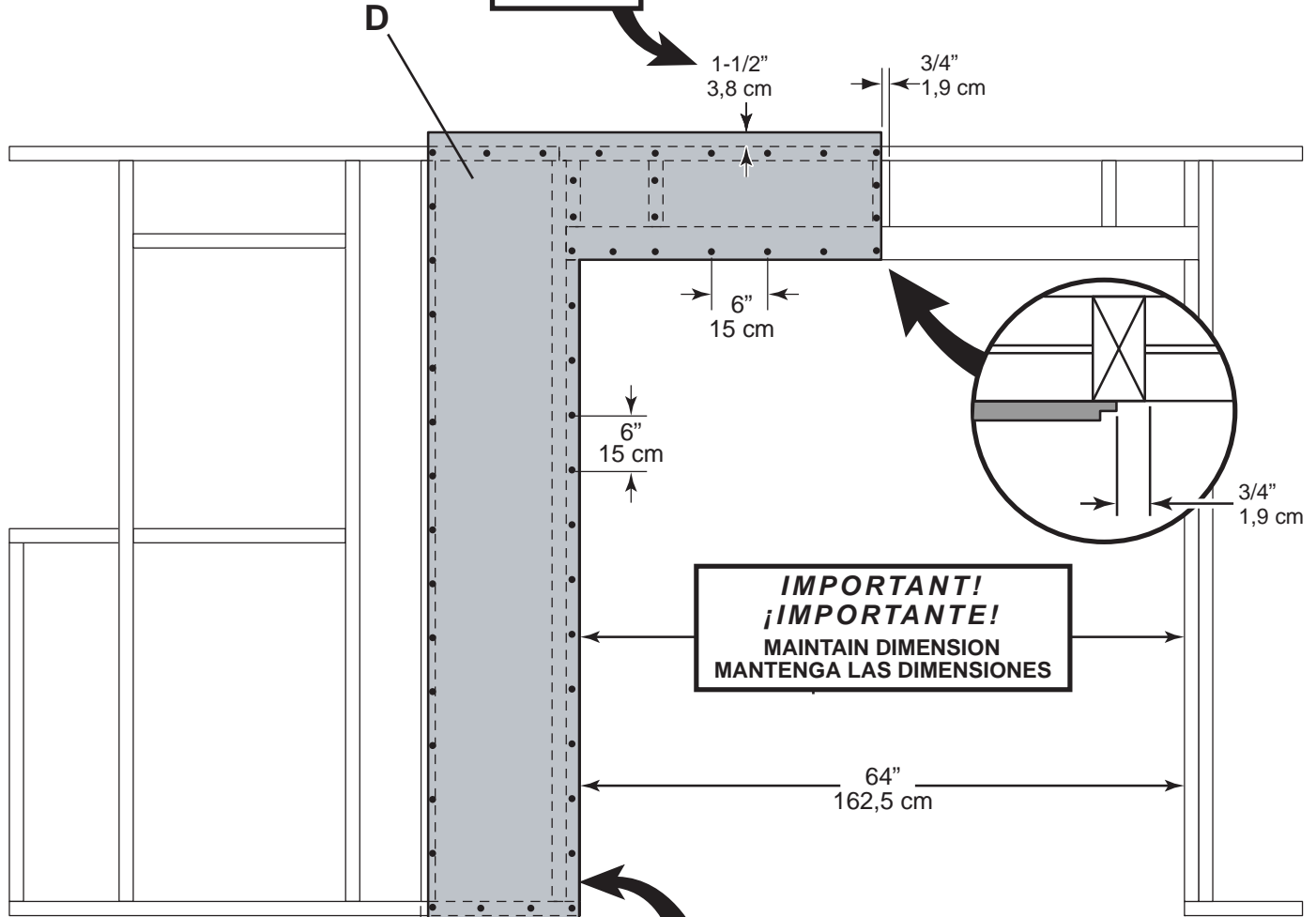

**IMPORTANT!**  
**¡IMPORTANTE!**  
MAINTAIN DIMENSION  
MANTENGA LAS DIMENSIONES

Install with painted side facing up.  
Instale el lado con la pintura para arriba.

Align left side of panel with the 3/4" mark.  
Alinee el izquierda del panel con la marca de 1,9 cm.

**HINT:**  
Use floor as a work surface!  
**CONSEJO:**  
¡Utilice el piso como superficie de trabajo!

**FRONT WALL**

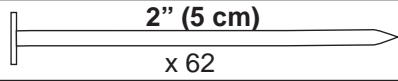

**PARED DELANTERA**

See Page 8 for Building Tip!  
¡Ver la página 8 para un consejo!



**Important Dimension**  
Dimensión importante

Install with painted side facing up.  
Instale el lado con la pintura para arriba.

1-1/2"  
3,8 cm

Flush  
Al ras

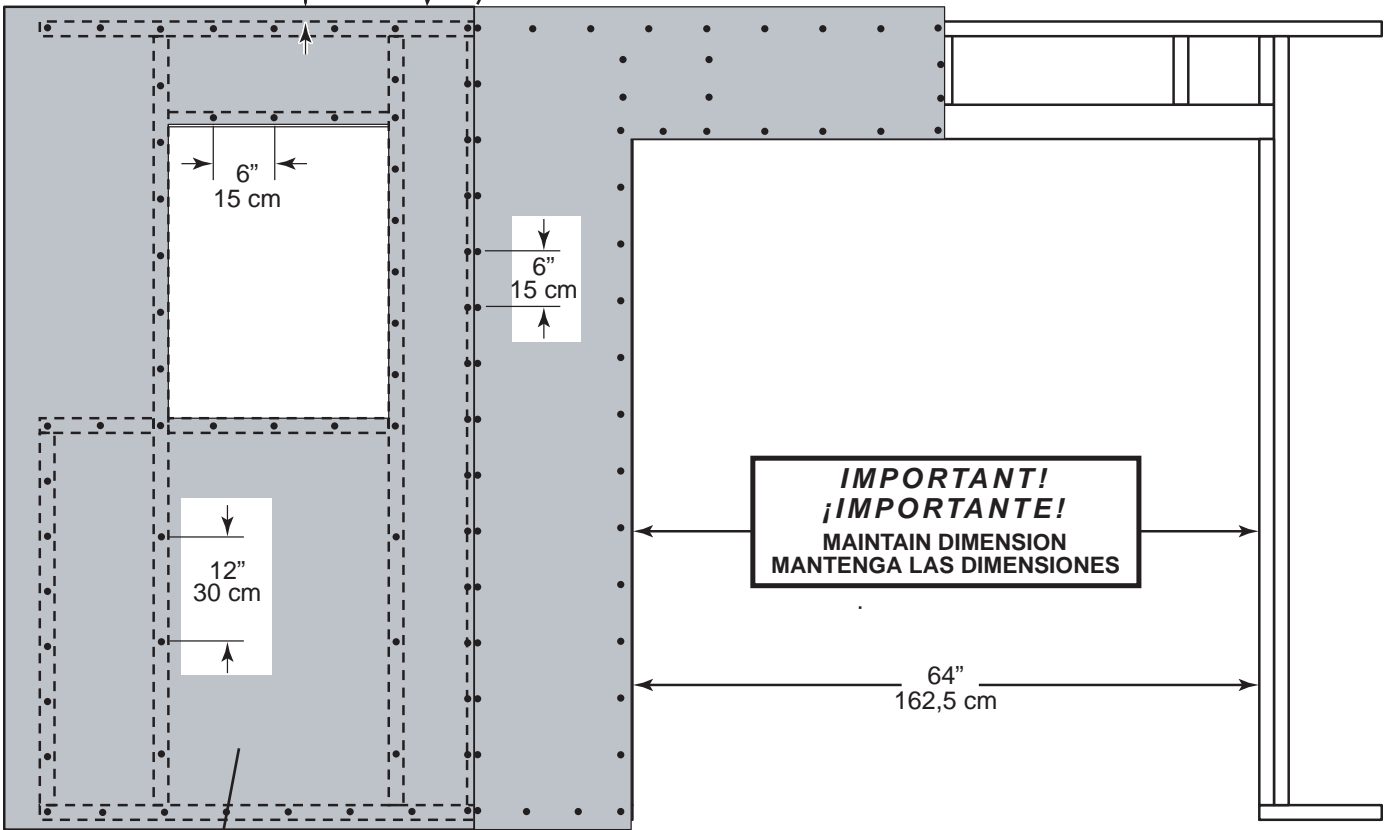

Flush  
Al ras

E

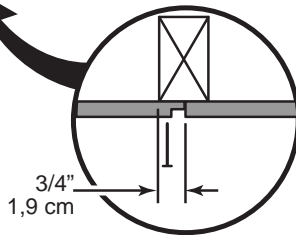

**HINT:**

Use floor as a work surface!

**CONSEJO:**

¡Utilice el piso como superficie de trabajo!

**FRONT WALL**

**PARED DELANTERA**

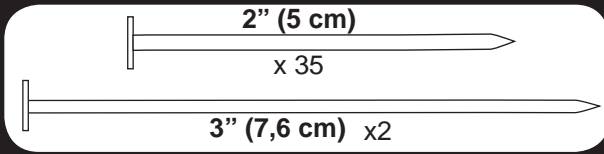

See Page 8 for Building Tip!  
¡Ver la página 8 para un consejo!

  
**Important Dimension**  
Dimensión importante

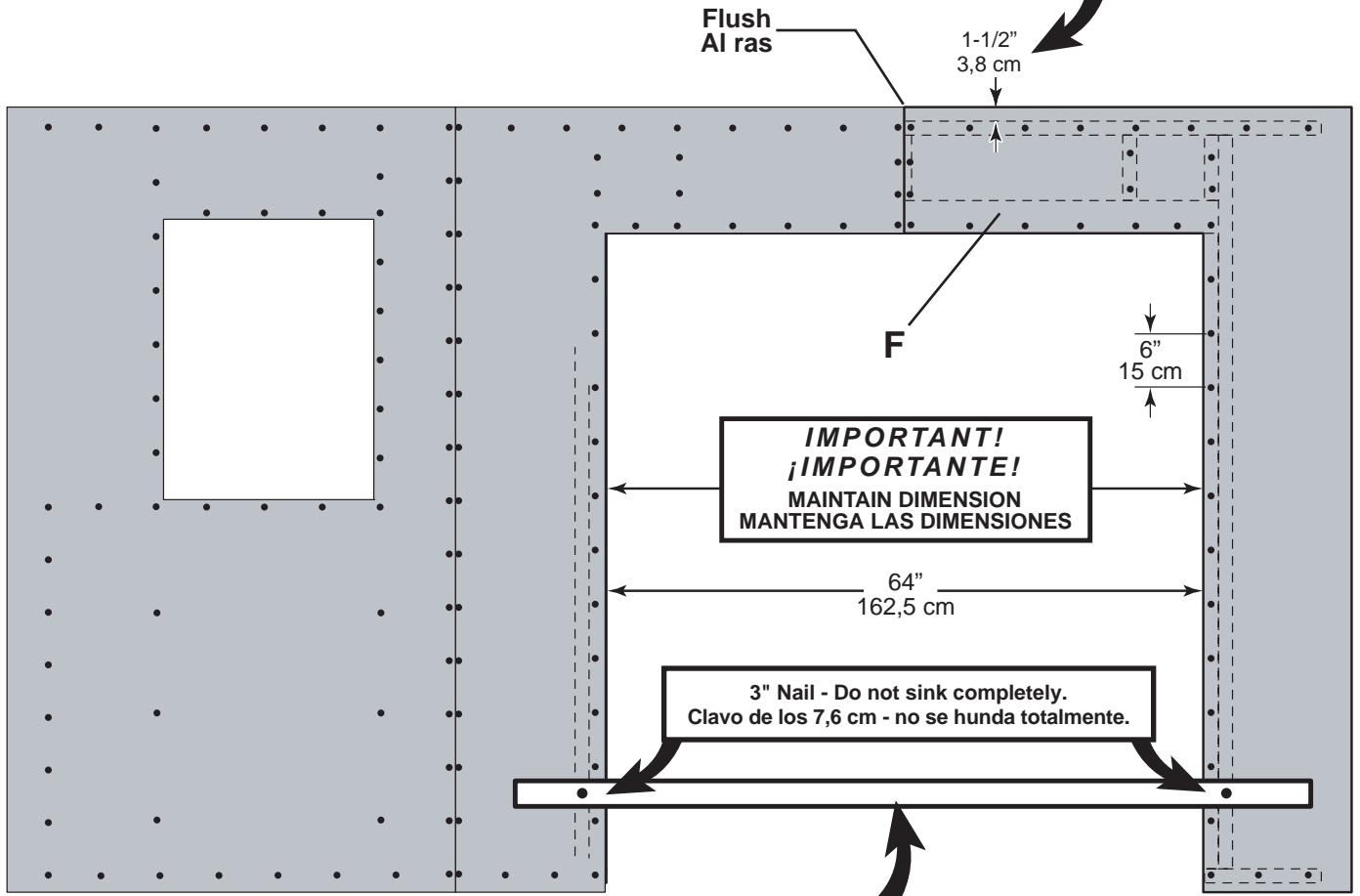

Hint: Use part "TP" (2 x 4 x 96") as a temporary support until wall is installed.  
Consejo: Utilice la parte "TP" (5 x 10 x 244 cm) como a la ayuda temporal hasta la pared está instalada.

BACK WALL

3" (7,6 cm)

x 24

PARED TRASERA

See Page 8 for Building Tip!  
¡Ver la página 8 para un consejo!

**TOP / TAPA**

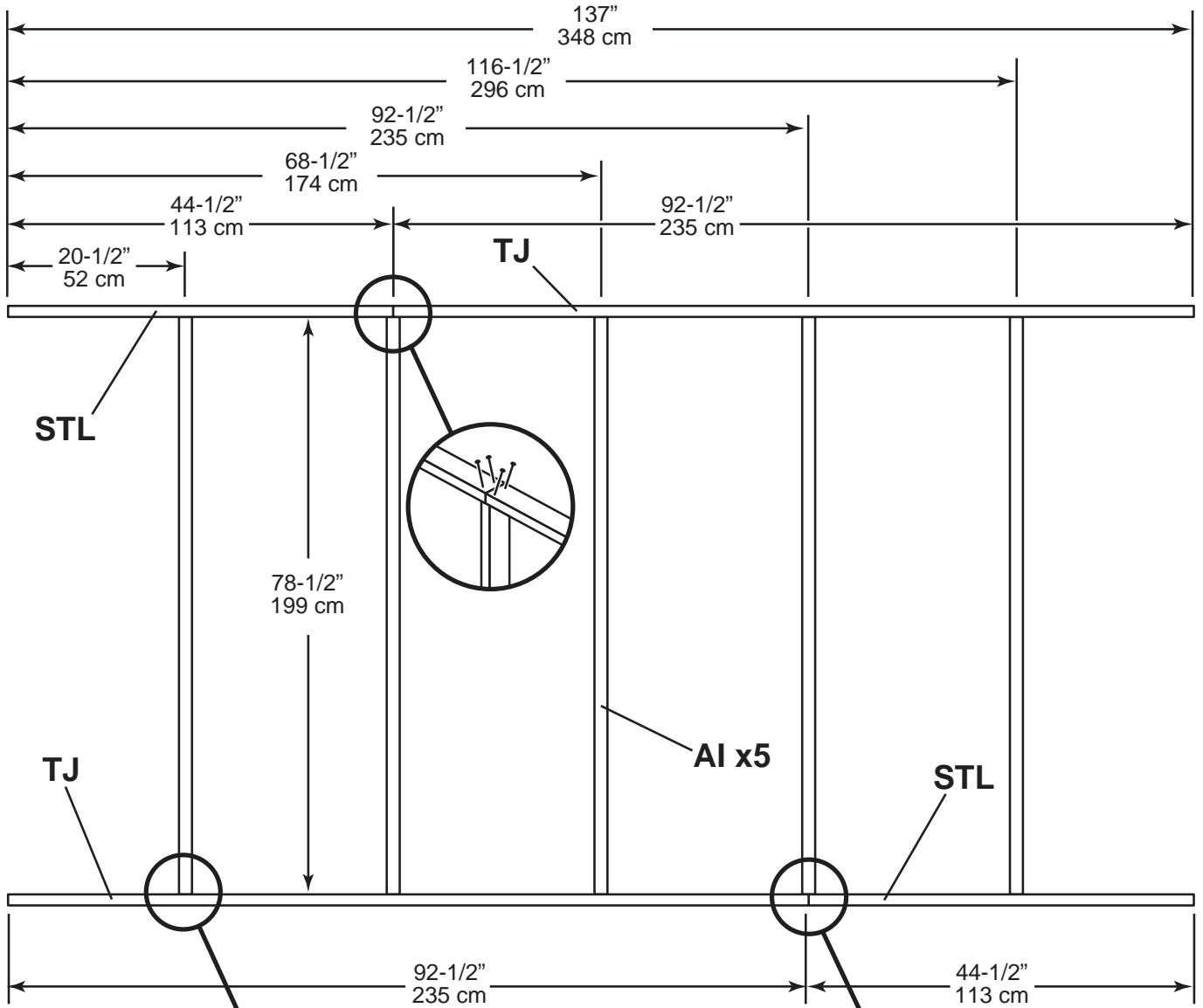

**BOTTOM  
PARTE INFERIOR**



**HINT:**

Use floor as a work surface!

**CONSEJO:**

¡Utilice el piso como superficie de trabajo!

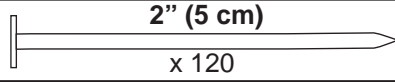

See Page 7 for Building Tip!!!  
 ¡Ver la página 7 para un consejo!!!

**Important Dimension**  
**Dimensión importante**

**TOP / TAPA**

**INSTALL THIS PANEL FIRST**  
**INSTALE EL ESTE PANEL PRIMER**

**BOTTOM / PARTE INFERIOR**

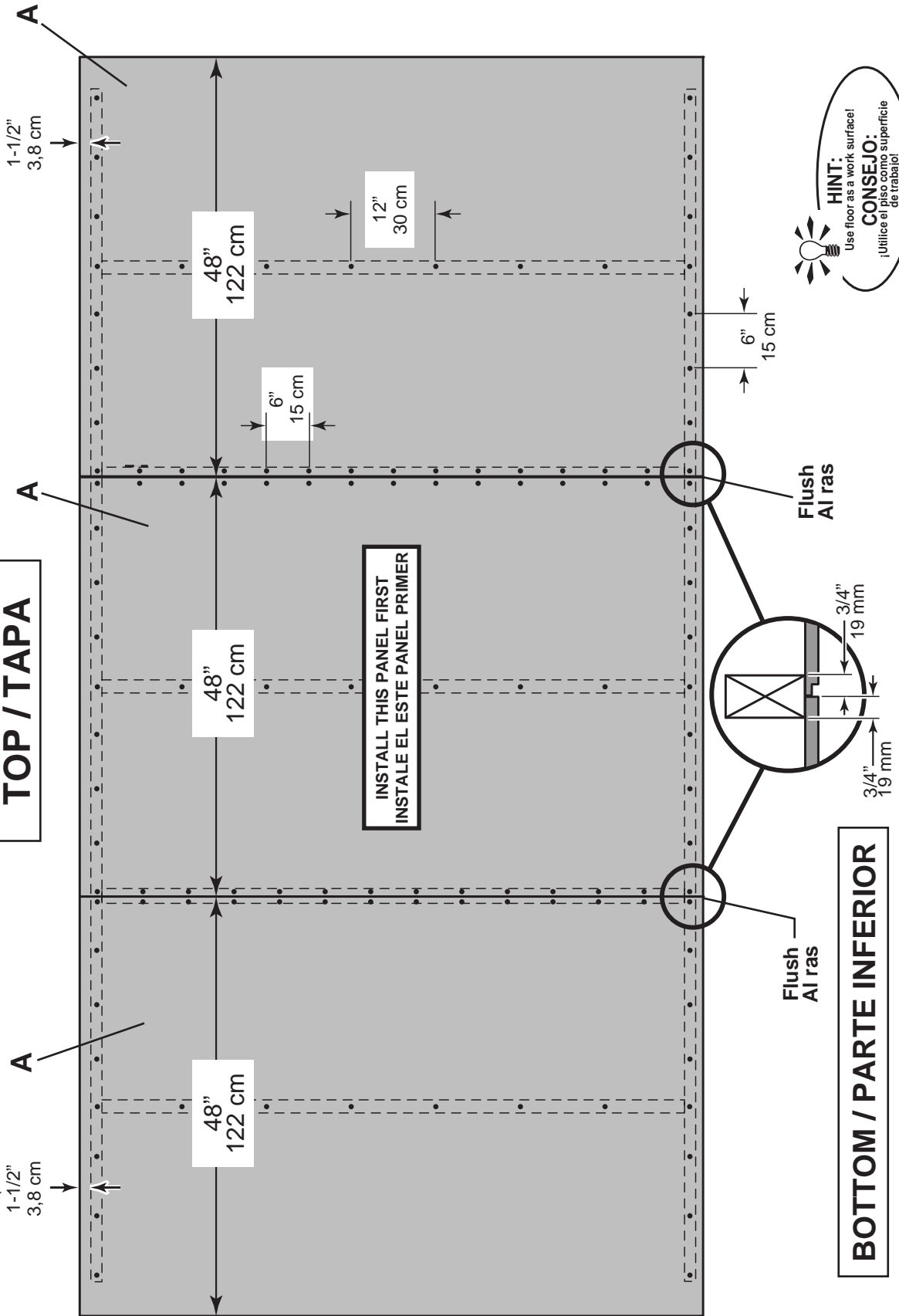

**HINT:**  
 Use floor as a work surface!  
**CONSEJO:**  
 ¡Utilice el piso como superficie de trabajo!



**LEFT WALL**

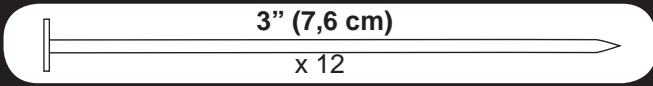

**PARED IZQUIERDA**

Do not sink nails completely.  
No hingue los clavos completamente.

Level wall and brace.  
Nivele el pared y refuerzala.

 1-1/2" Overhang  
Proyección 3,8 cm

3"  
7,6 cm

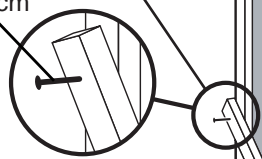

Center wall assembly on floor.  
Centre la asamblea de la pared sobre el piso.

Temporary (TP)  
No permanente (TP)

3" Nails  
Clavos 7,6 cm

Flush  
Al ras

120"  
305 cm

3" Nail  
Clavo 7,6 cm

**FRONT  
FRENTE**

**LEFT WALL**

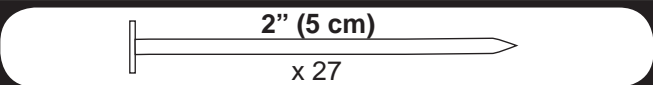

**PARED IZQUIERDA**

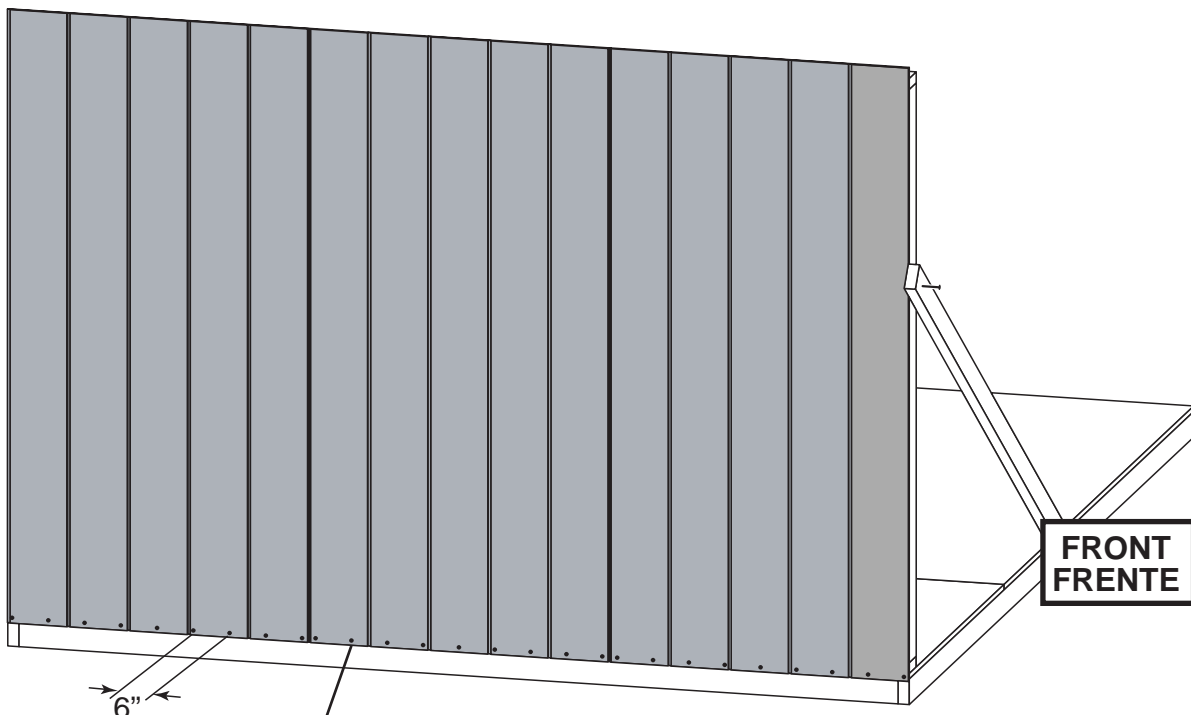

**FRONT  
FRENTE**

6"  
15 cm

2" Nails  
Clavos 5 cm

**RIGHT WALL**

3" (7,6 cm)

x 12

**PARED DERECHA**



1-1/2" Overhang  
Proyección 3,8 cm

Level wall and brace.  
Nivele el pared y refuerzala.

Do not sink nails completely.  
No hínque los clavos completamente.

Center wall assembly on floor.  
Centre la asamblea de la pared sobre el piso.

3" Nail  
Clavo 7,6 cm

Flush  
Al ras

**FRONT  
FRENTE**

Temporary  
No permanente

3"  
7,6 cm

**RIGHT WALL**

2" (5 cm)

x 27

**PARED DERECHA**

**FRONT  
FRENTE**

2" Nails  
Clavos 5 cm

6"  
15 cm

**BACK WALL**

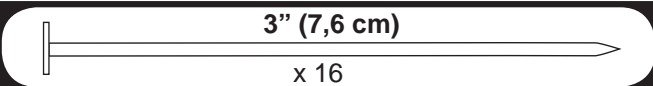

**PARED TRASERA**

 1-1/2" Overhang  
Proyección 3,8 cm

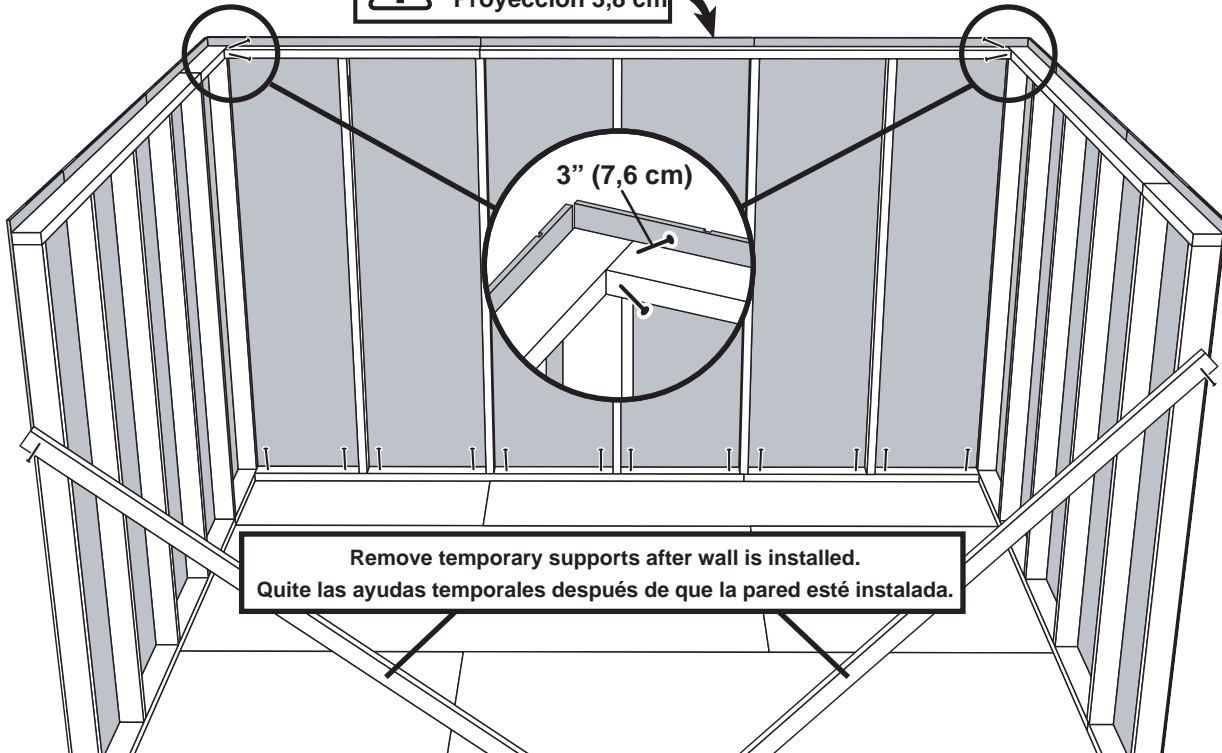

**BACK WALL**

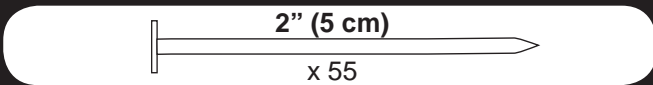

**PARED TRASERA**

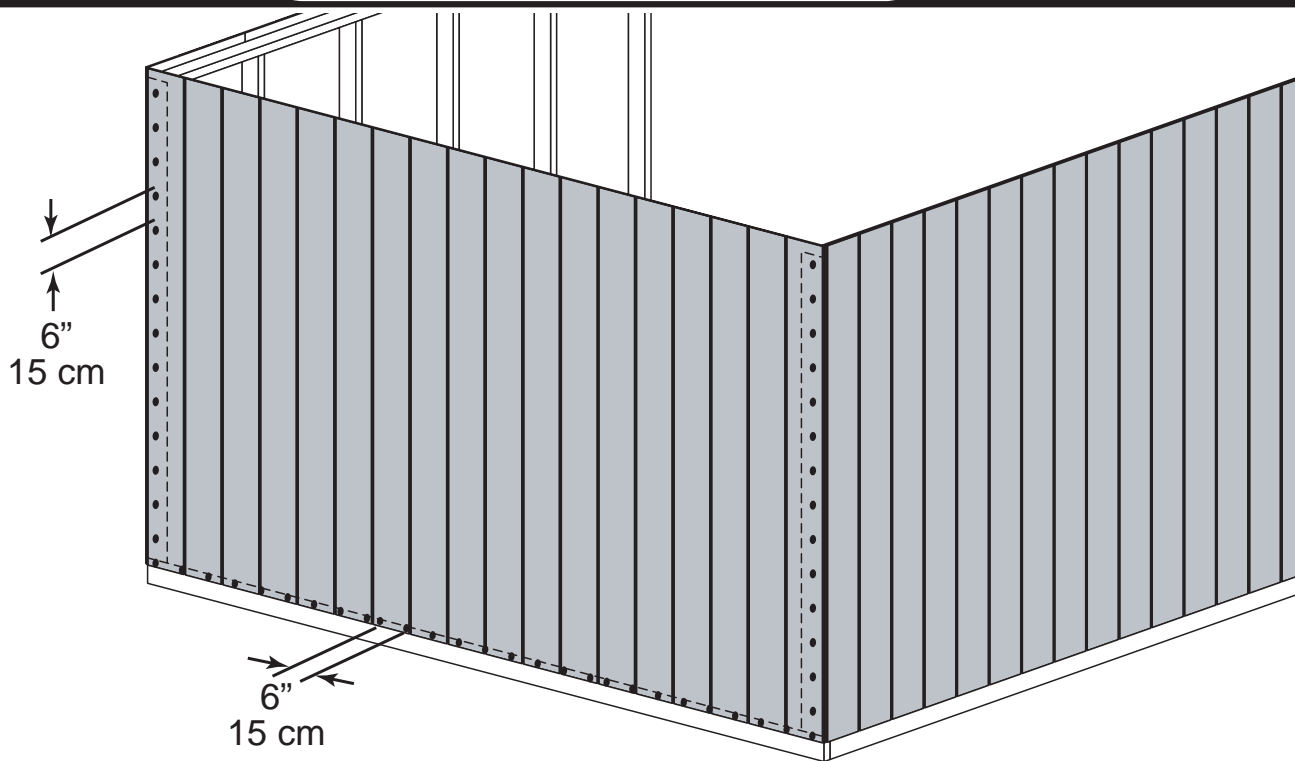

FRONT WALL

3" (7,6 cm)

x 14

PARED DELANTERA

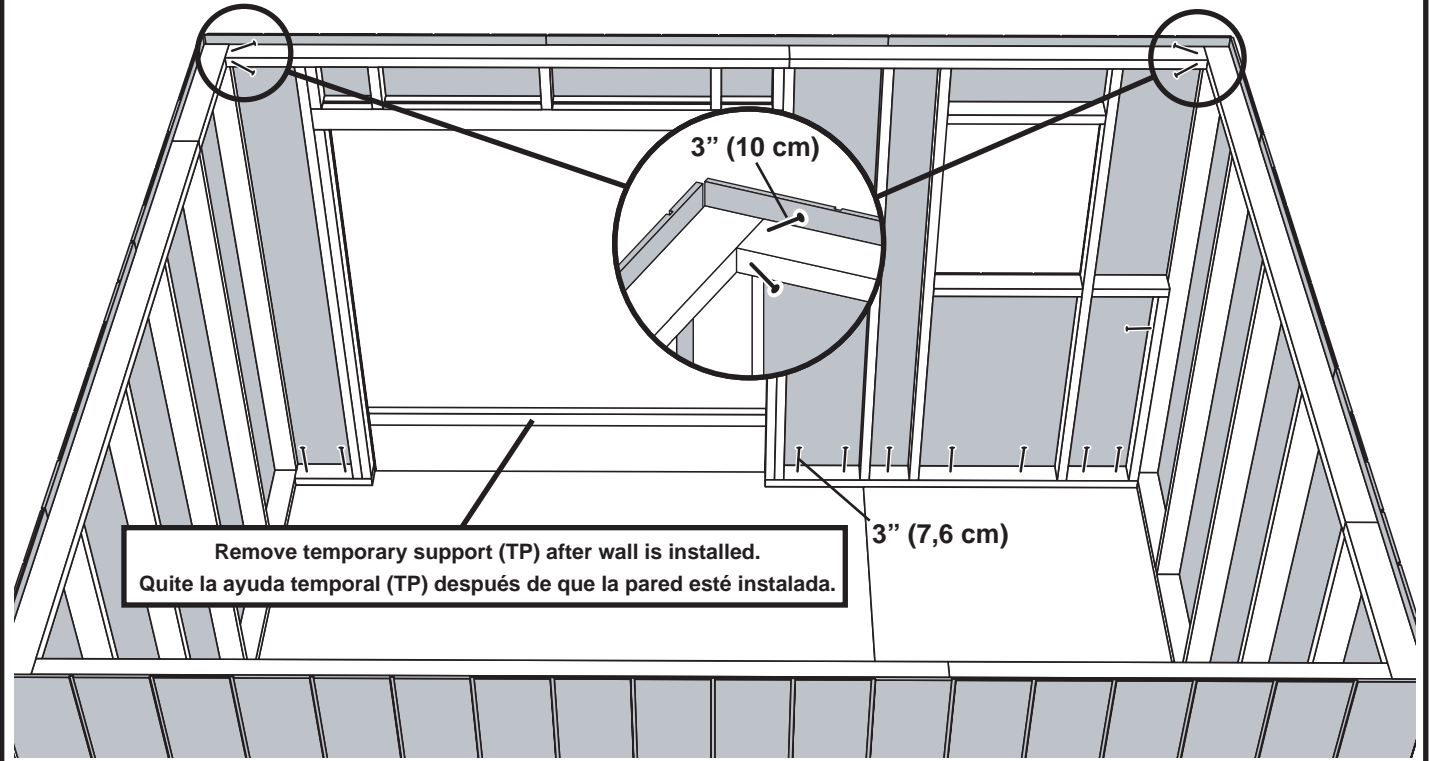

FRONT WALL

2" (5 cm)

x 46

PARED DELANTERA

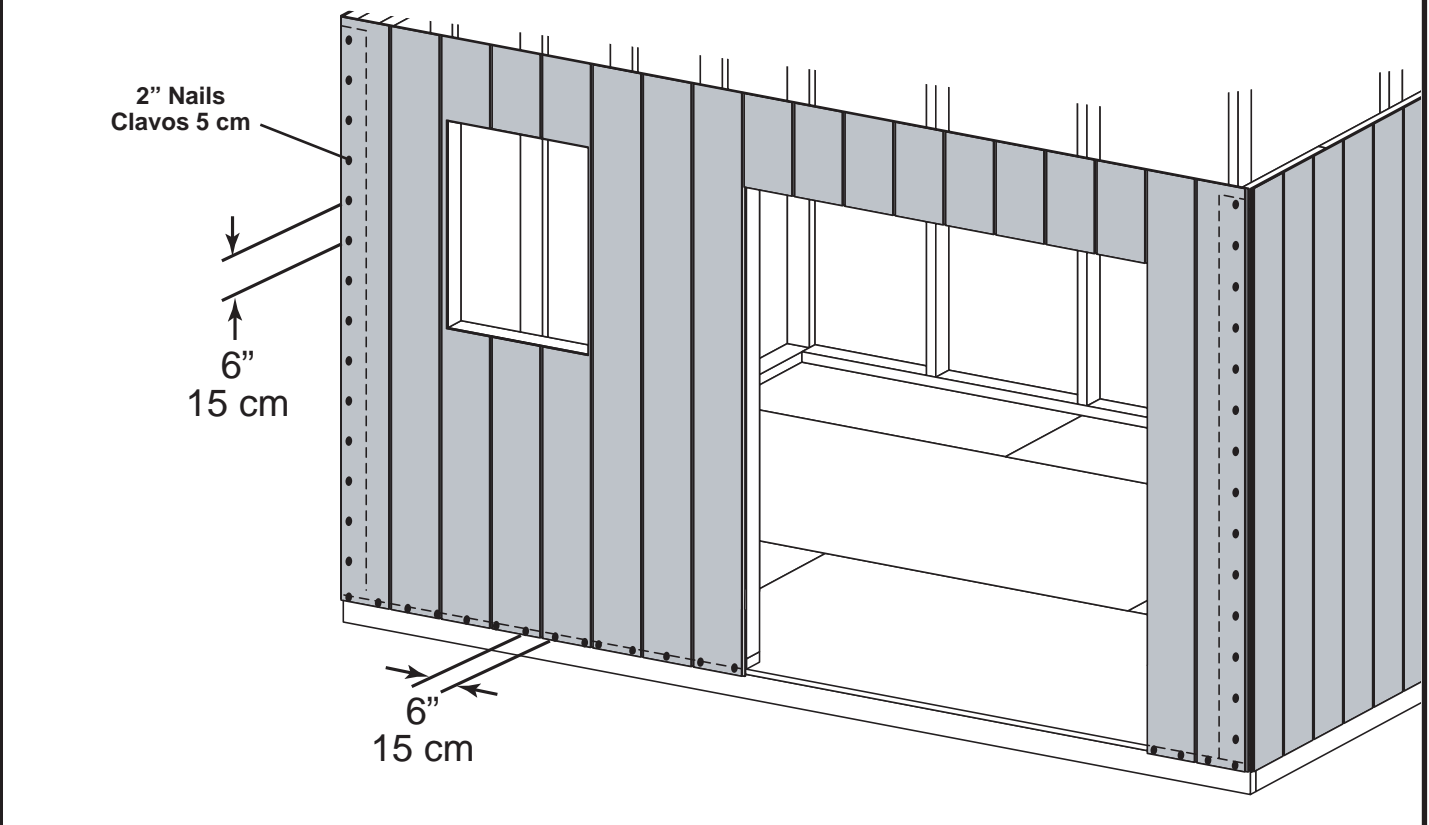

# WALL DOUBLERS

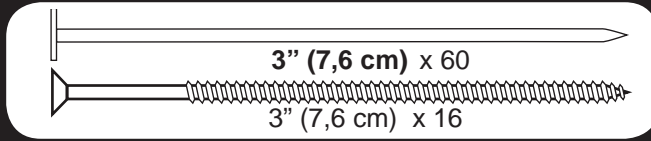

# DOBLADORES DE LA PARED



**(16) 3" Screws  
4 SCREWS PER  
CORNER.**  
**(16) 7,6 cm Tornillos  
4 tornillos por  
esquina**

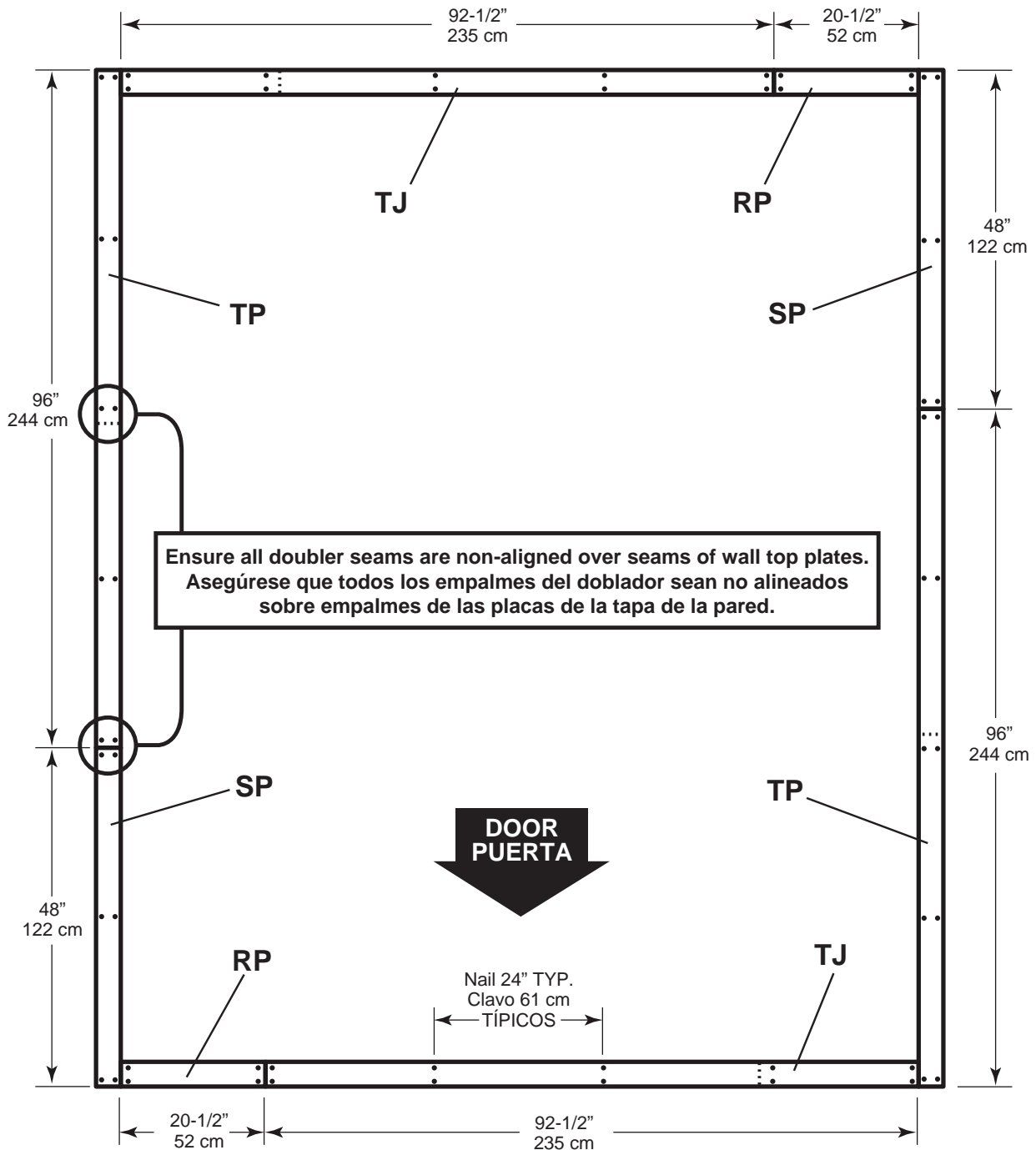

**IMPORTANT!**  
Build **two** rafters with 1 gusset.  
**¡IMPORTANTE!**  
Haga **dos** viga con 1 escudete.

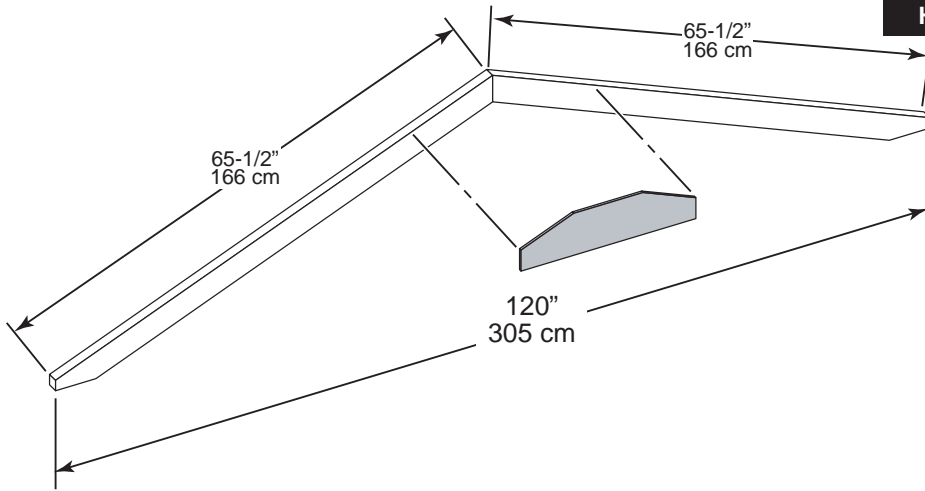

**x2**

**IMPORTANT!**  
Build **five** rafters with 2 gussets.  
**¡IMPORTANTE!**  
Haga **cinco** vigas con 2 escudetes.

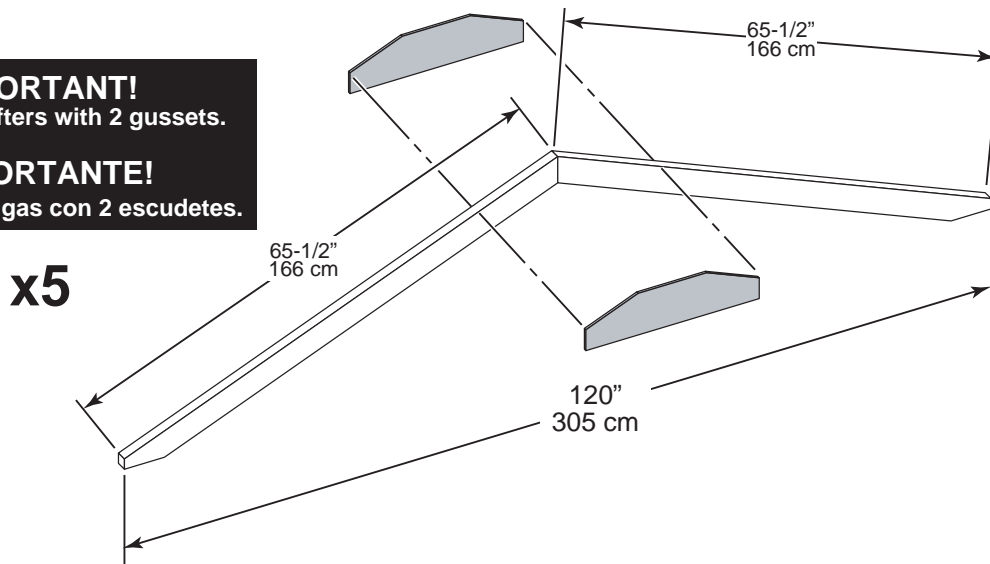

**x5**

**HINT:**  
Use floor and walls to help assemble rafters!  
**CONSEJO:**  
¡Utilice el piso y las paredes para ayudar a montar los vigas!

Use floor, wall and part QL as a fixture to help build the rafters.

Utilice el piso, la pared y la parte QL como un accesorio para ayudar a construir los vigas.

**3" (7,5 cm)**  
Do not sink nails completely.  
No golpee totalmente en clavos.

QL

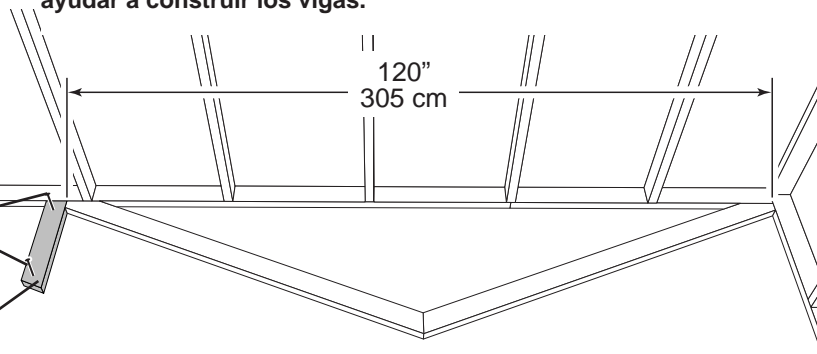

**ROOF TRUSS**

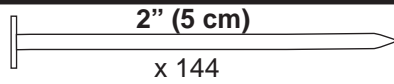

**VIGA**

Build two rafters with 1 gusset.

Haga dos viga con 1 escudete.

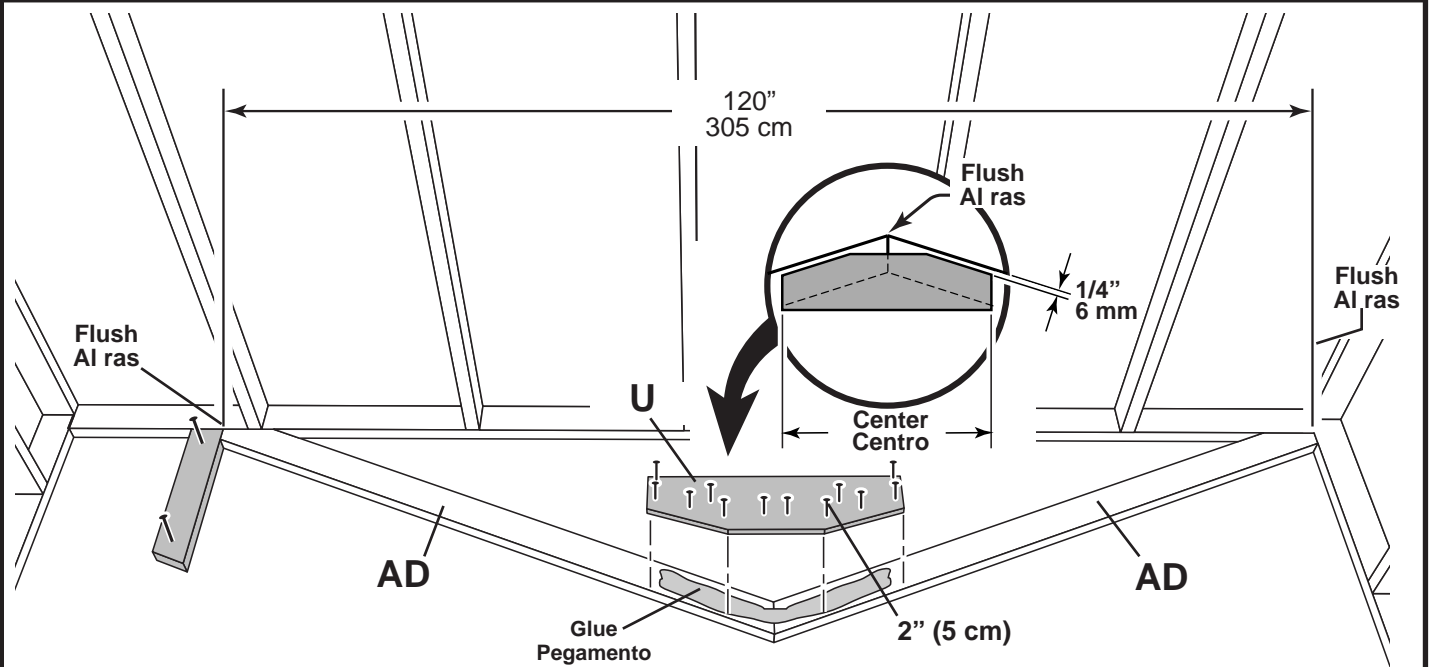

**BUILD ONLY TWO.  
HAGA SOLAMENTE DOS.  
x2**

Build five rafters with 2 gussets.

Haga cinco vigas con 2 escudetes.

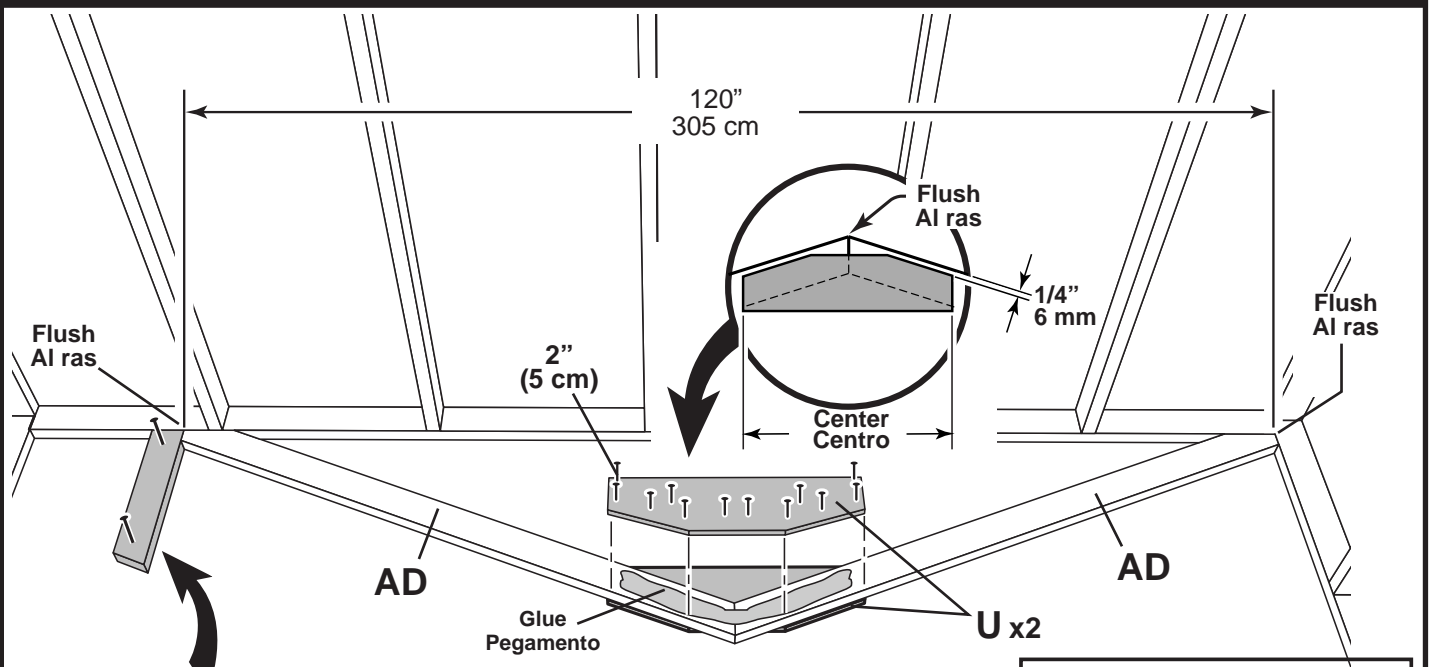

Remove QL after all trusses are assembled.  
Quite QL después de que todos los vigas estén montados.

**BUILD ONLY FIVE.  
HAGA SOLAMENTE CINCO.  
x5**

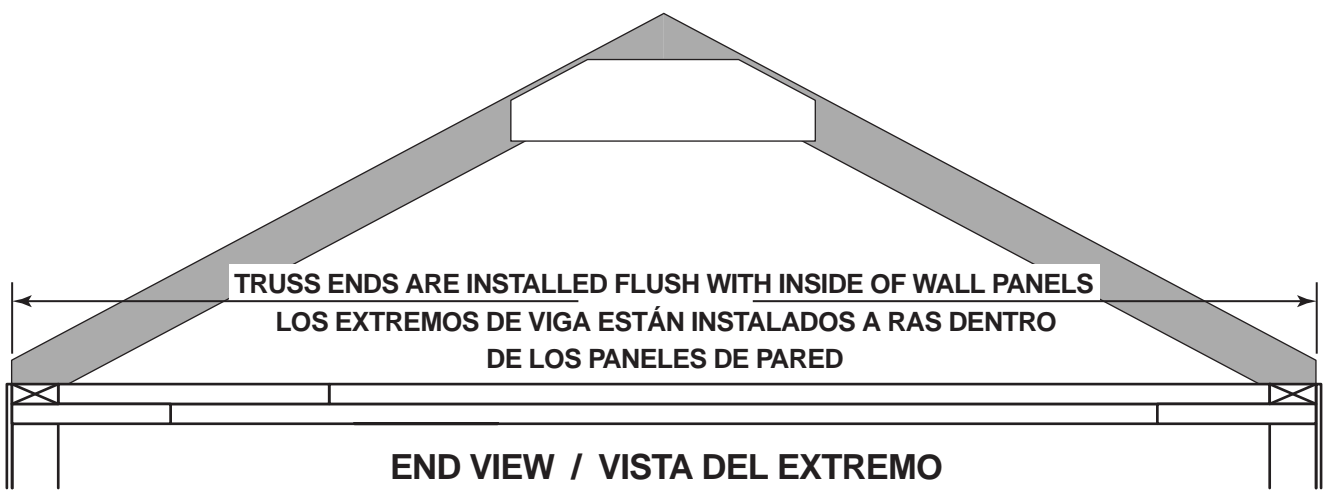
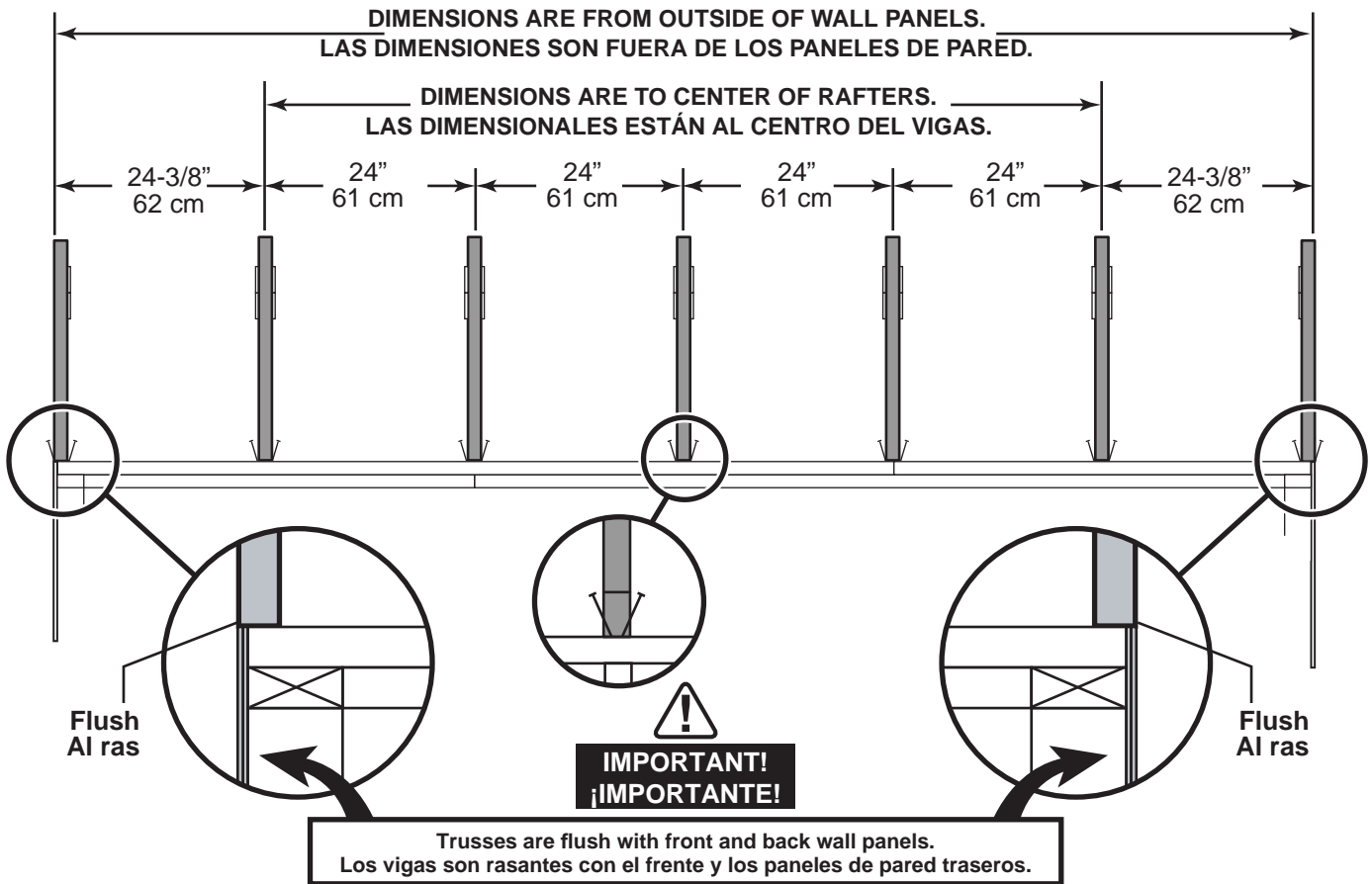
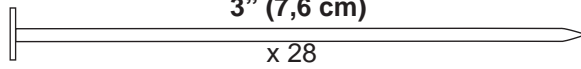



TRIM

1-1/4" (32 mm)



MOLDURA

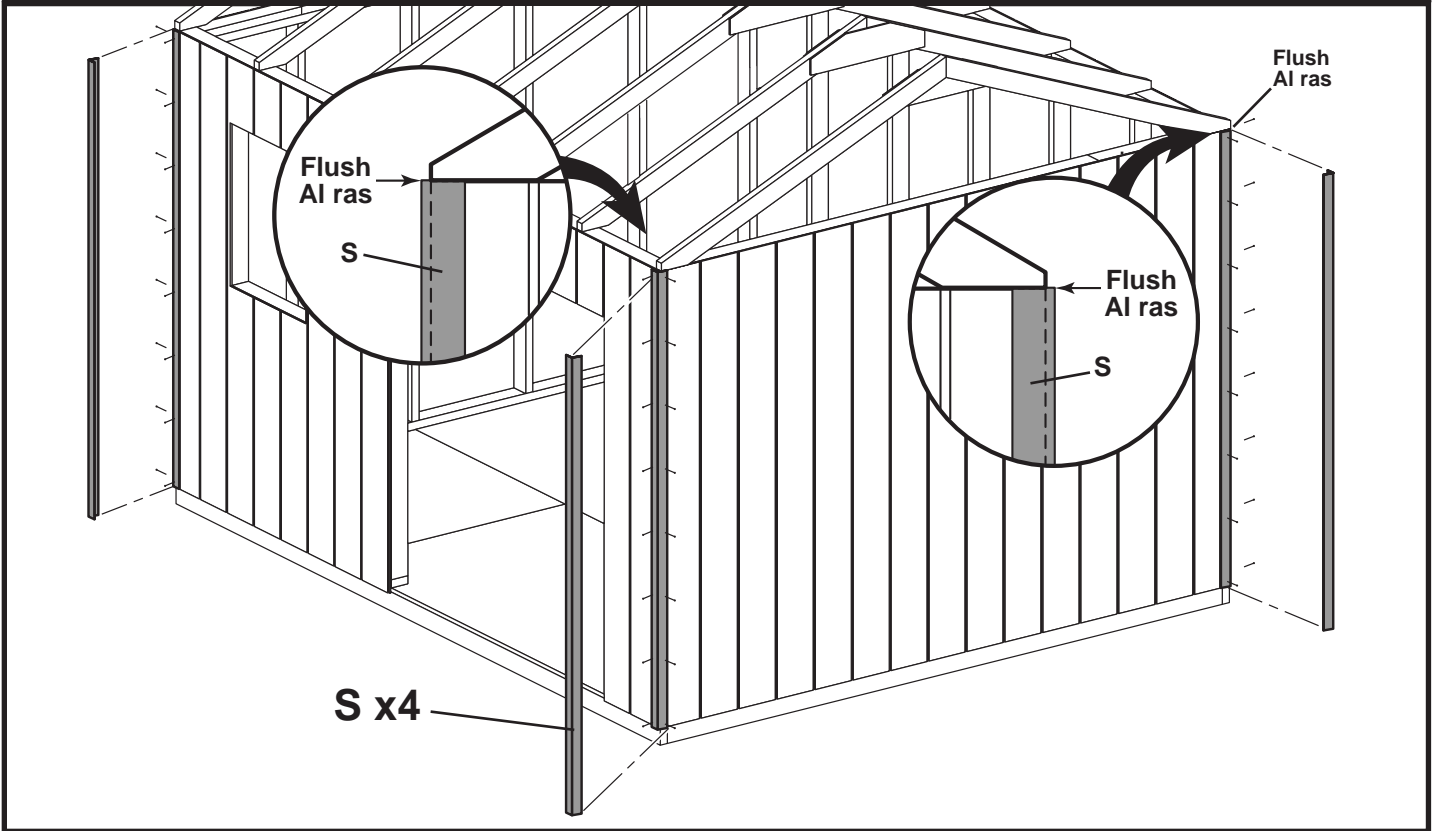

WALL

2" (5 cm)

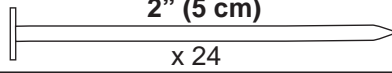

PARED

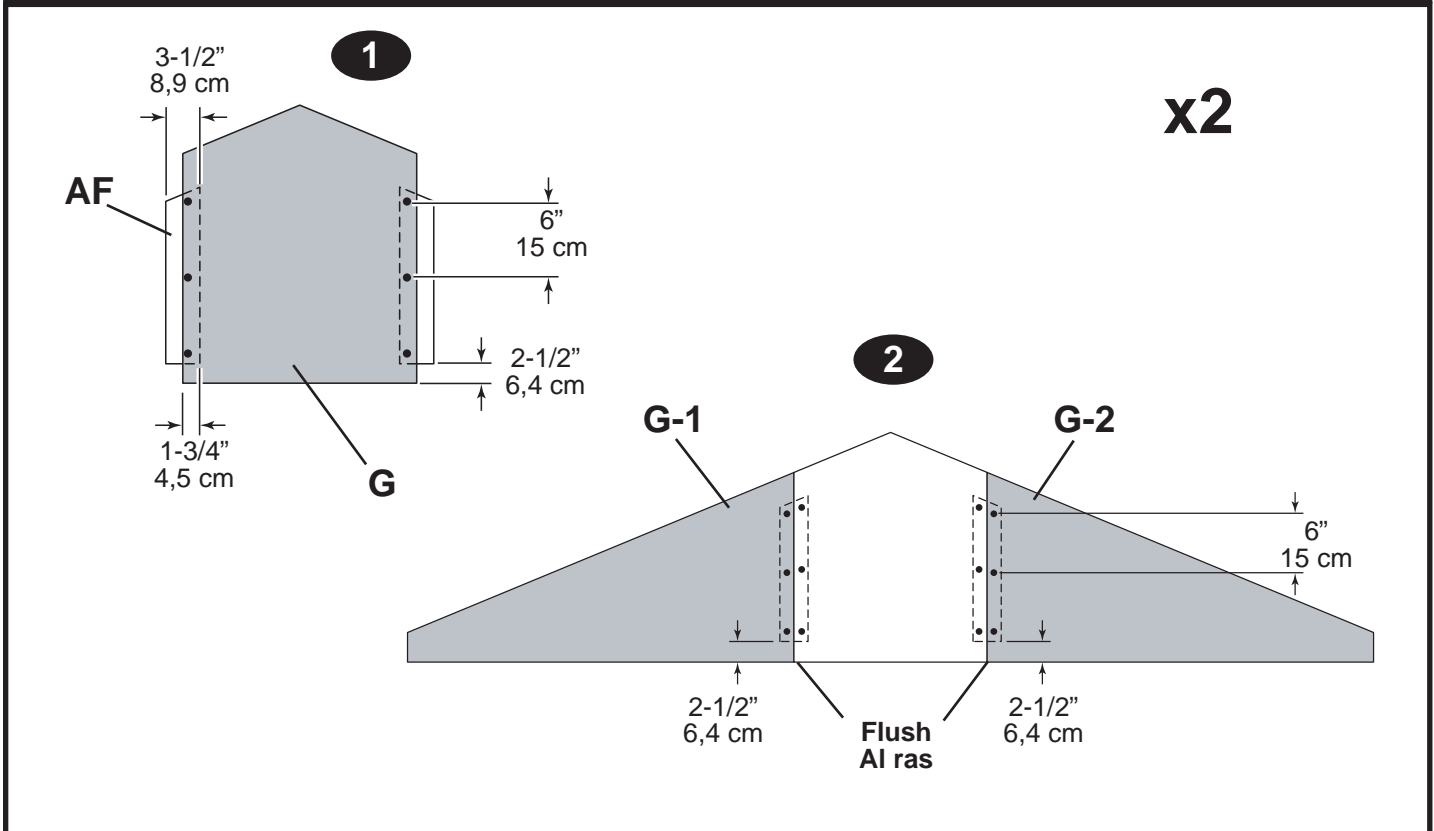

WALL

PARED

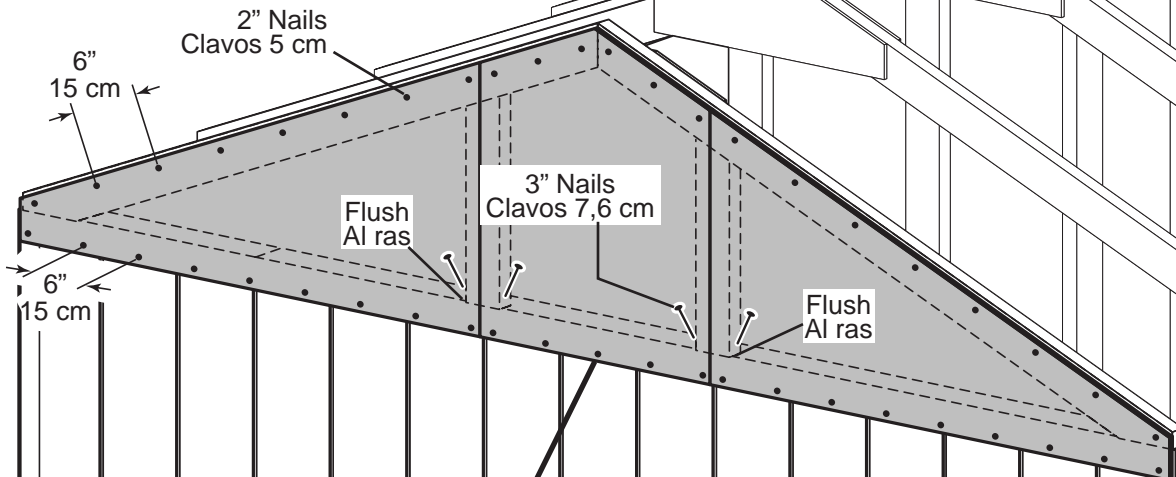
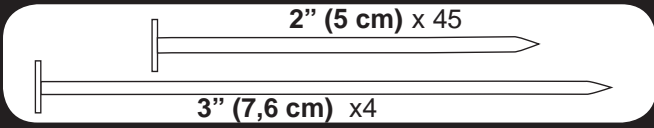

Center gable panel assembly on back wall.  
Montaje del panel de centro del aguilón en la pared trasera.

LEFT WALL  
PARED IZQUIERDA

WALL

PARED

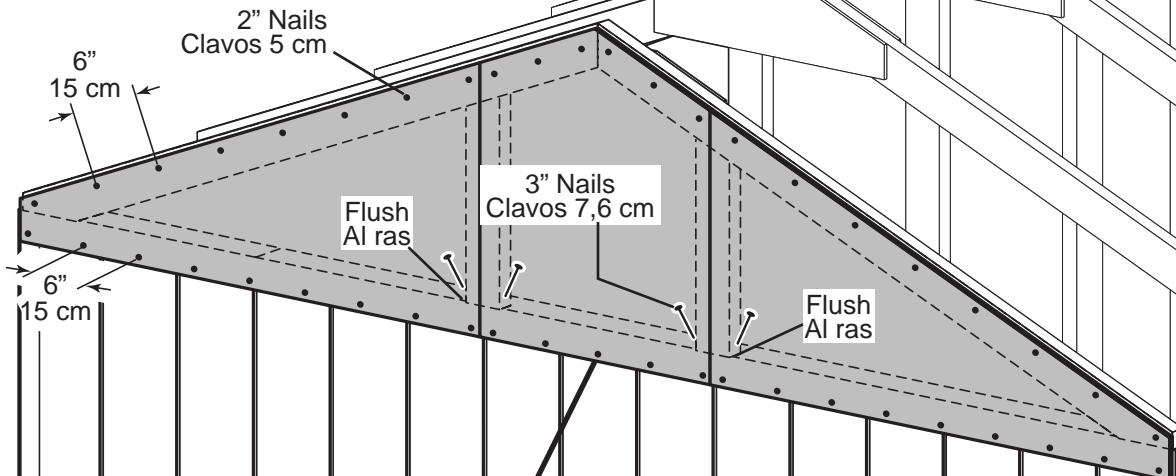
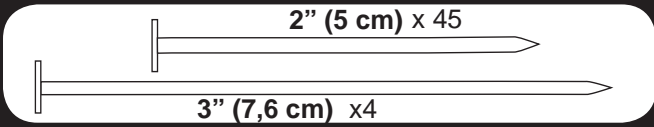

Center gable panel assembly on right wall.  
Montaje del panel de centro del aguilón en la pared derecha.

RIGHT WALL  
PARED DERECHA

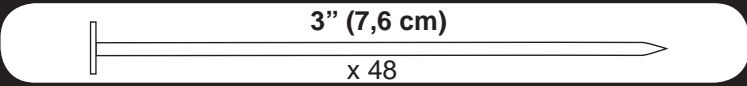

**1**

Ensure parts TP and RL are aligned perfectly on a flat surface. Spread glue across RL and TP as shown. Asegúrese que las piezas TP y RL estén alineadas perfectamente en una superficie plana. Distribuya el pegamento a través de RL y del TP como se muestra.

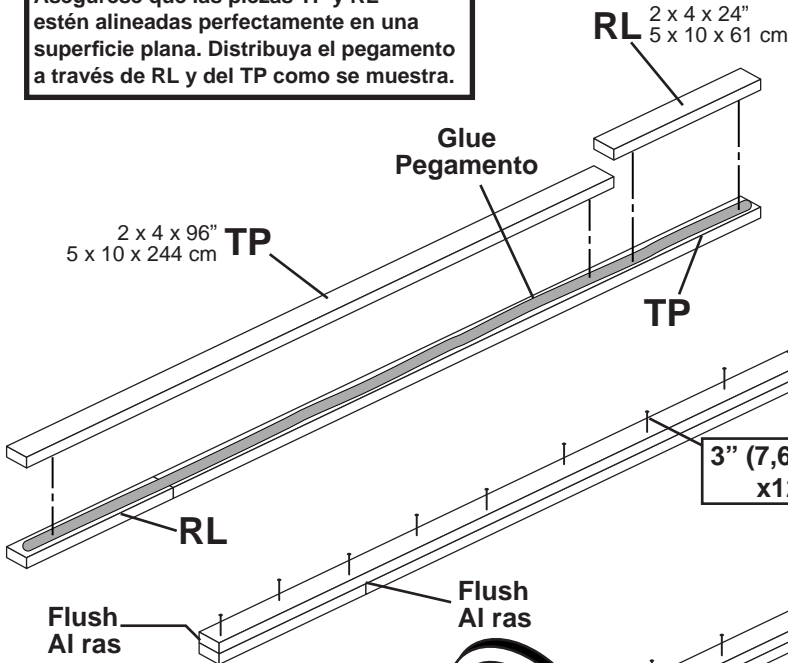

**2**

Assemble joist with 3 inch nails in a staggered pattern. Monte la vigueta con clavos 7,6 cm en un patrón escalonado.

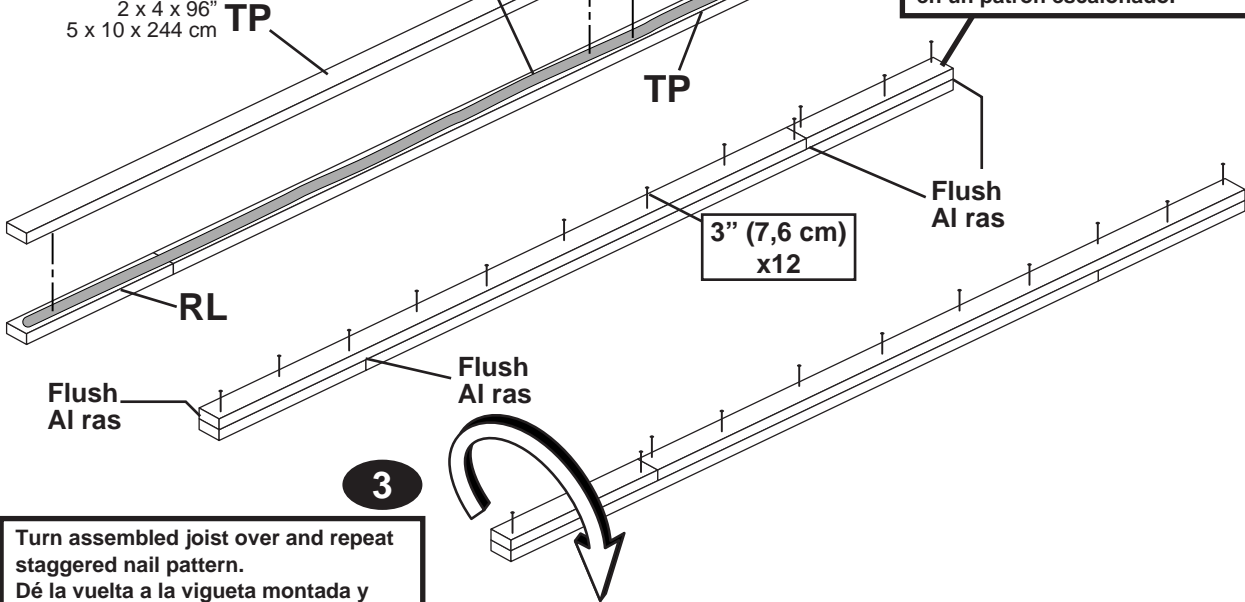

**3**

Turn assembled joist over and repeat staggered nail pattern. Dé la vuelta a la vigueta montada y repita el patrón escalonado del clavo.

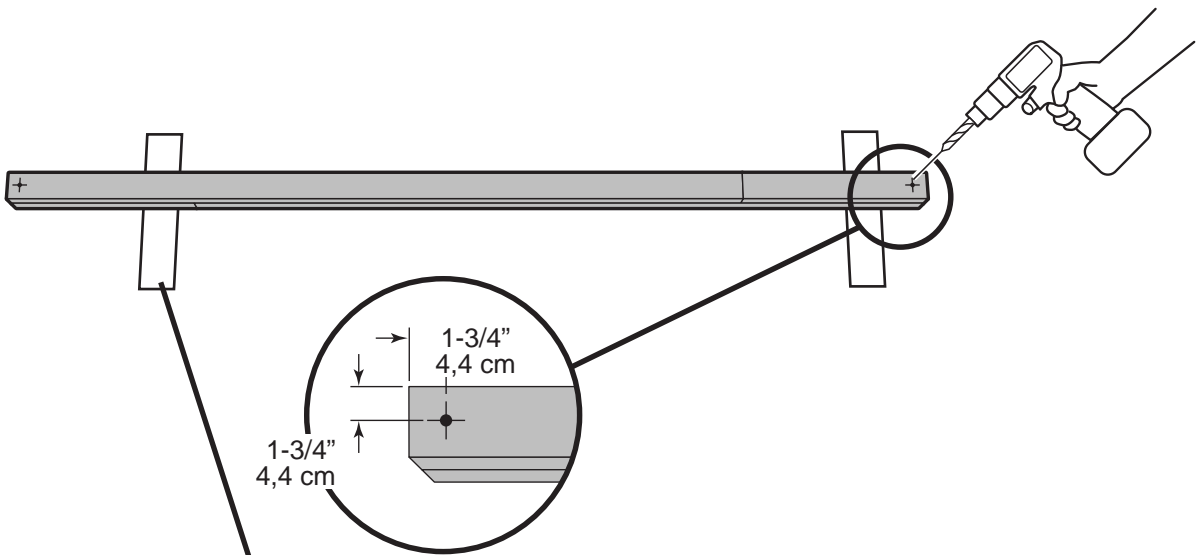

**4**

Support and drill a 7/16 inch hole through each end of each joist. Apoye el vigueta y perfore un agujero de 11 milímetros a través de finales de cada vigueta.

LOFT

3" (7,6 cm)

x 18

DESVÁN

5

Flush  
Al ras

Flush  
Al ras

Flush  
Al ras

LW 2 x 3 x 23-7/8"  
5 x 7,6 x 60,6 cm

PT 2 x 3 x 96"  
5 x 7,6 x 244 cm

LEVEL  
NIVEL

LEVEL  
NIVEL

3" Nails  
Clavos 7,6 cm

3-1/2"  
9 cm

AO

2 x 4 x 22-1/2"  
5 x 10 x 57 cm

LEFT WALL  
PARED IZQUIERDA

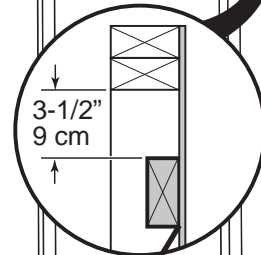

Flush at wall panel.  
AO es rasante con el panel de pared.

LOFT

3/8" HDW. SET:  
5-1/2" Hex bolt,  
2 flat washers, lock nut

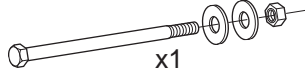

x1

HDW. SISTEMA 9,5 mm:  
Perno del hexágono 14 cm, dos arandelas  
planas, tuerca de fijación

DESVÁN

6

LOFT JOIST

VIGUETA DEL DESVÁN

5-1/2" Hex bolt  
Perno del hexágono  
14 cm

Flat washer  
Arandela plana

Lock nut  
Tuerca de fijación

Flat washer  
Arandela plana

Tighten lock nut securely.  
Apriete las tuercas de  
fijación con seguridad.

WINDOW  
VENTANA

Clamp or hold in place. Drill through joist and studs with 7/16" drill bit.  
Abrazadera o asimiento en el lugar. Perfore a través de las vigueta y de los  
montantes con un pedacito de taladro de 11 milímetros.

LOFT

3" (7,6 cm)

x4

DESVÁN

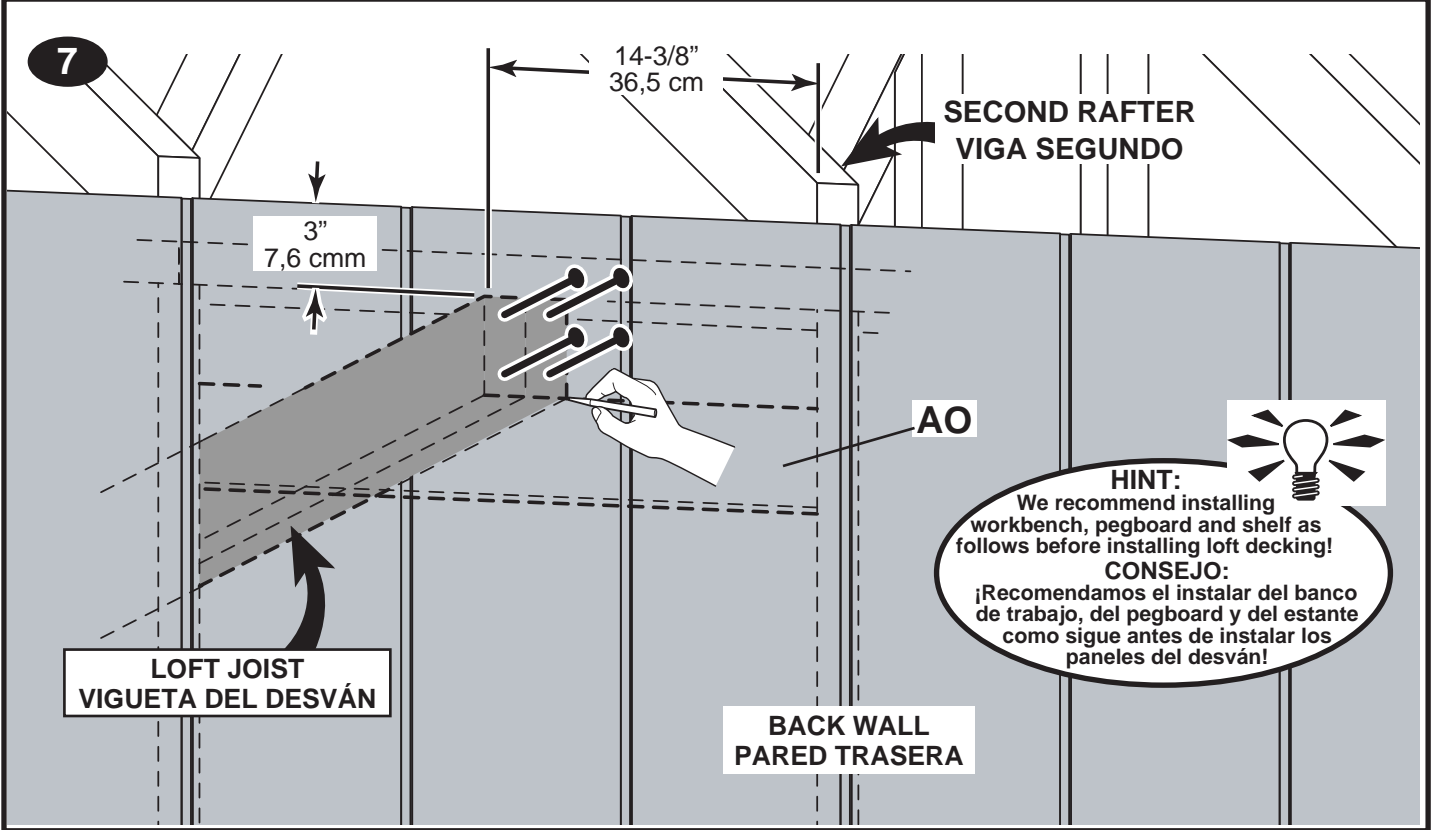

**HINT:**  
We recommend installing workbench, pegboard and shelf as follows before installing loft decking!

**CONSEJO:**  
¡Recomendamos el instalar del banco de trabajo, del pegboard y del estante como sigue antes de instalar los paneles del desván!



BENCH

2" (5 cm)

x 20

BANCO

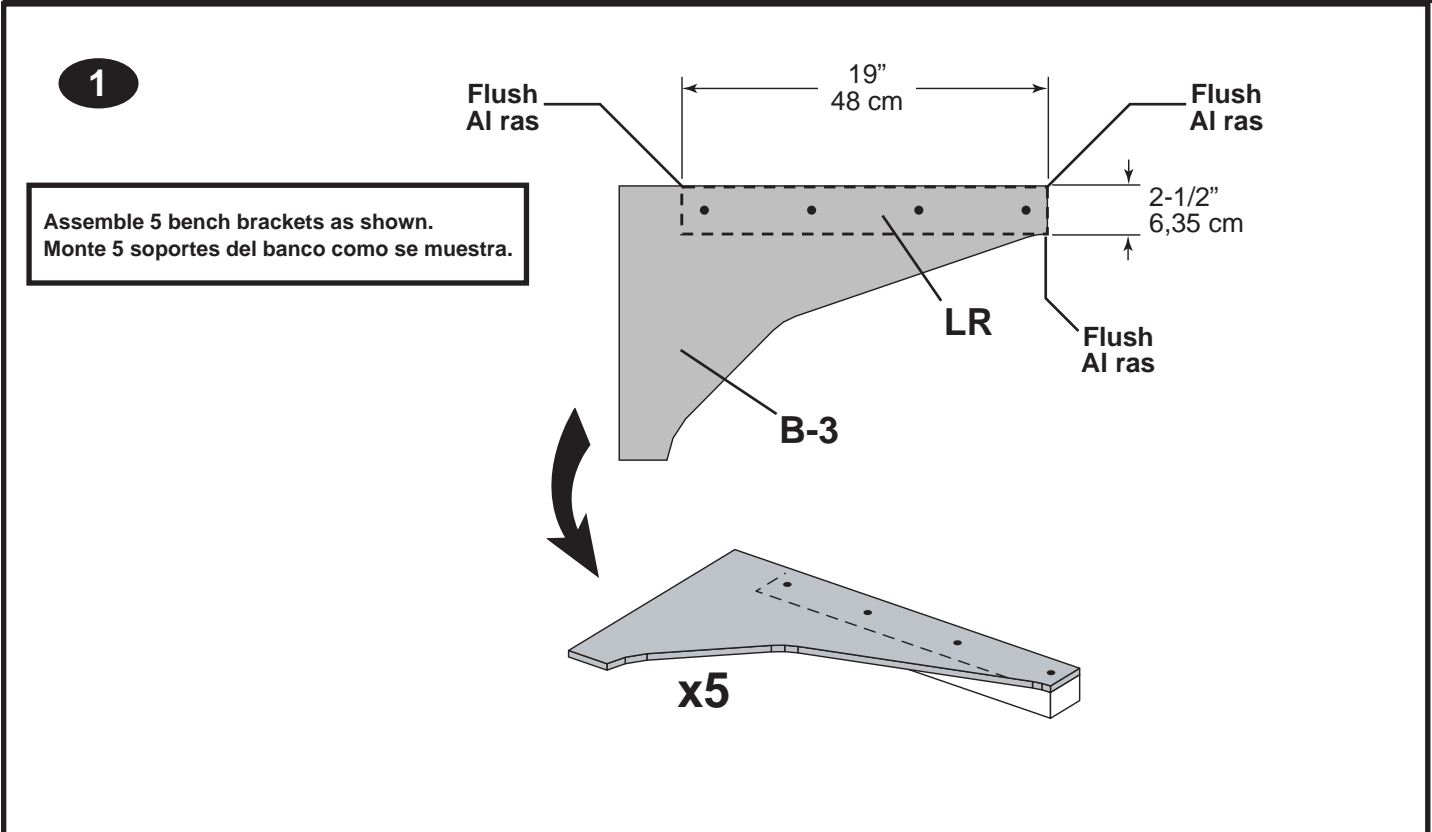

**1**

Assemble 5 bench brackets as shown.  
Monte 5 soportes del banco como se muestra.

BENCH

3" (7,6 cm)

BANCO

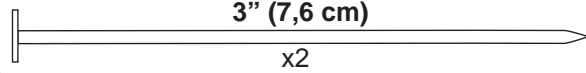

2

WINDOW OPENING

ABERTURA DE LA VENTANA

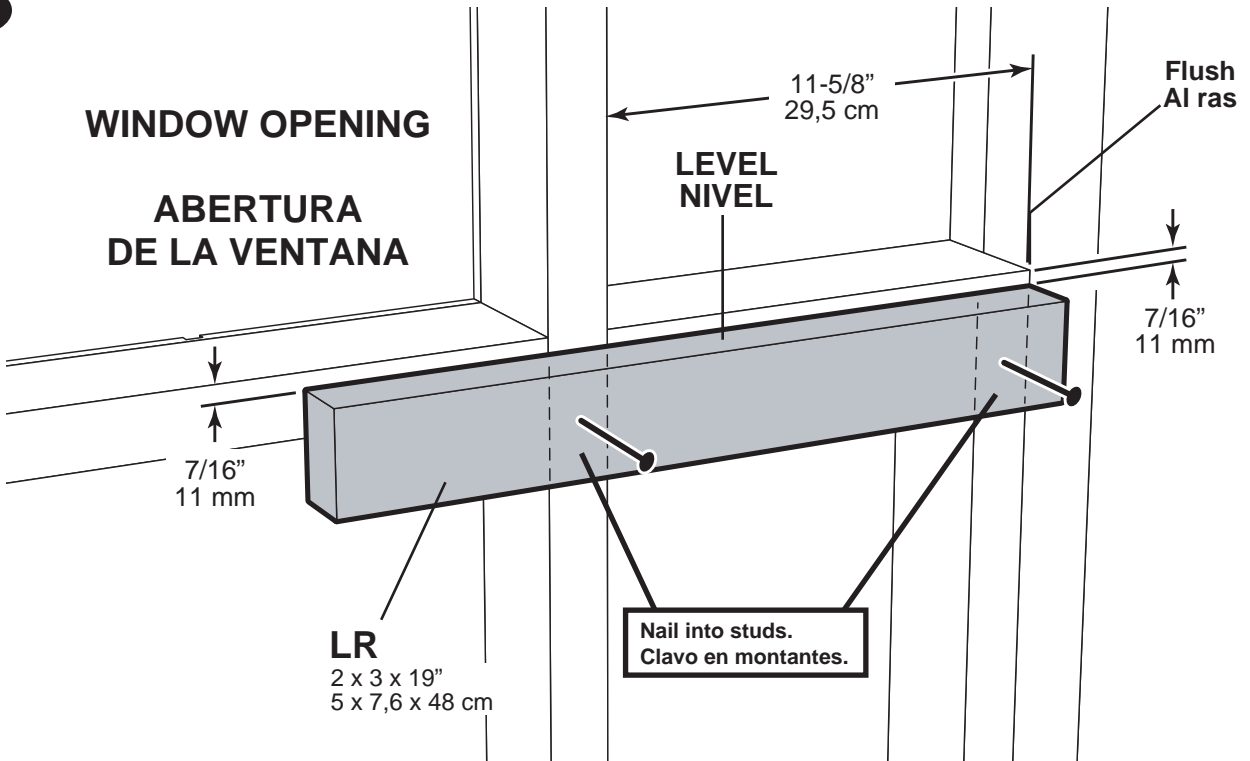

BENCH

2" (5 cm)

BANCO

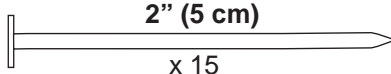

3

Install five bench brackets level with installed bench support (LR) at window.  
 Instale cinco soportes del banco llano con la ayuda instalada del banco (LR) en la ventana.

Reference this height.  
 Refiérase a esta altura.

Corner Stud  
 Montante de la esquina

LR

SAME DIMENSION  
 LA MISMA DIMENSIÓN

LEVEL NIVEL

Flush Al ras

FLOOR / PISO

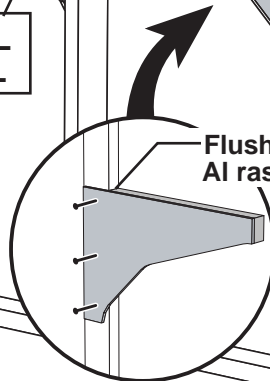

BENCH

2" (5 cm)

x 24

BANCO

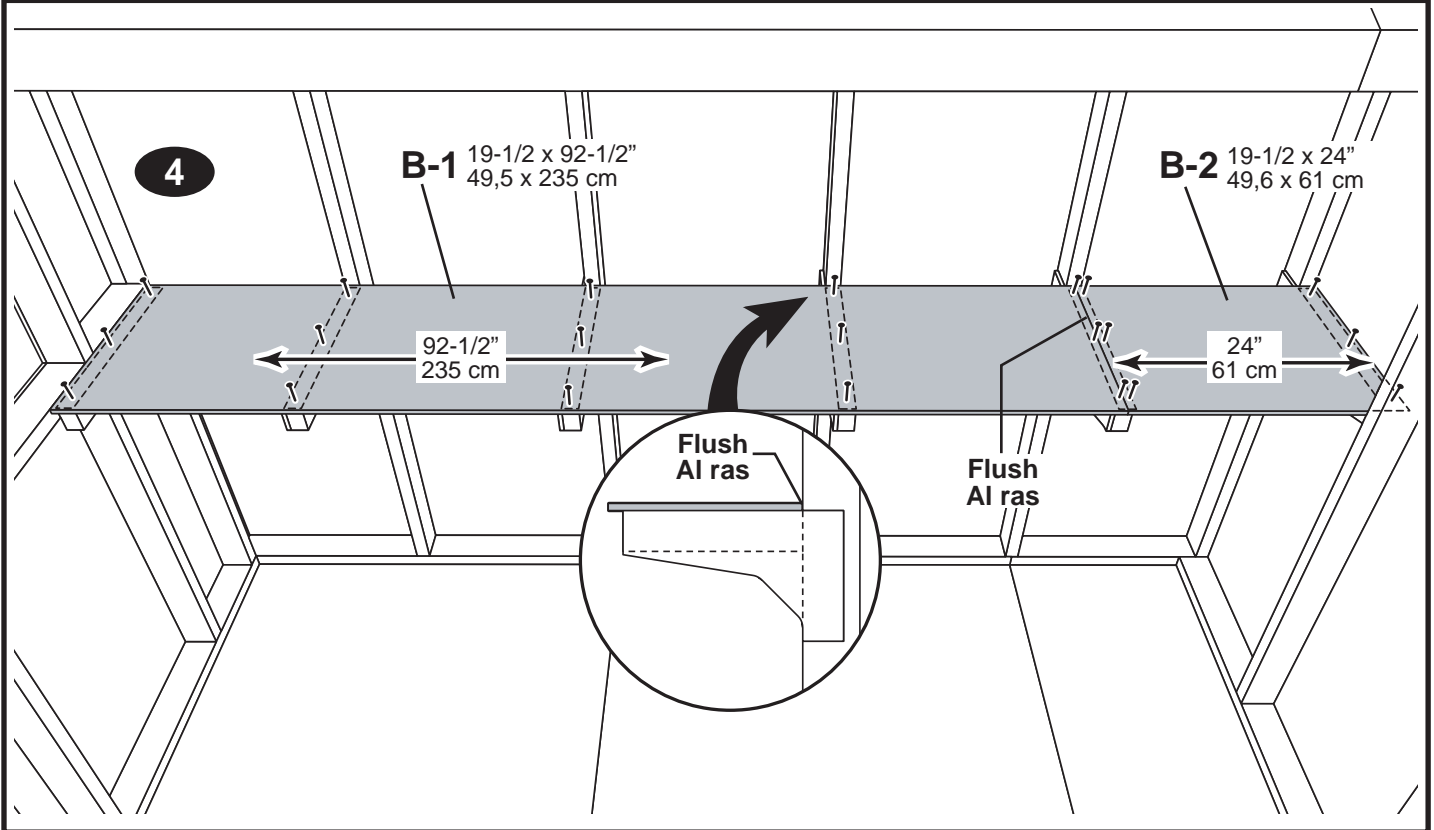

BENCH

2" (5 cm)

x 12

3" (7,6 cm)

x1

BANCO

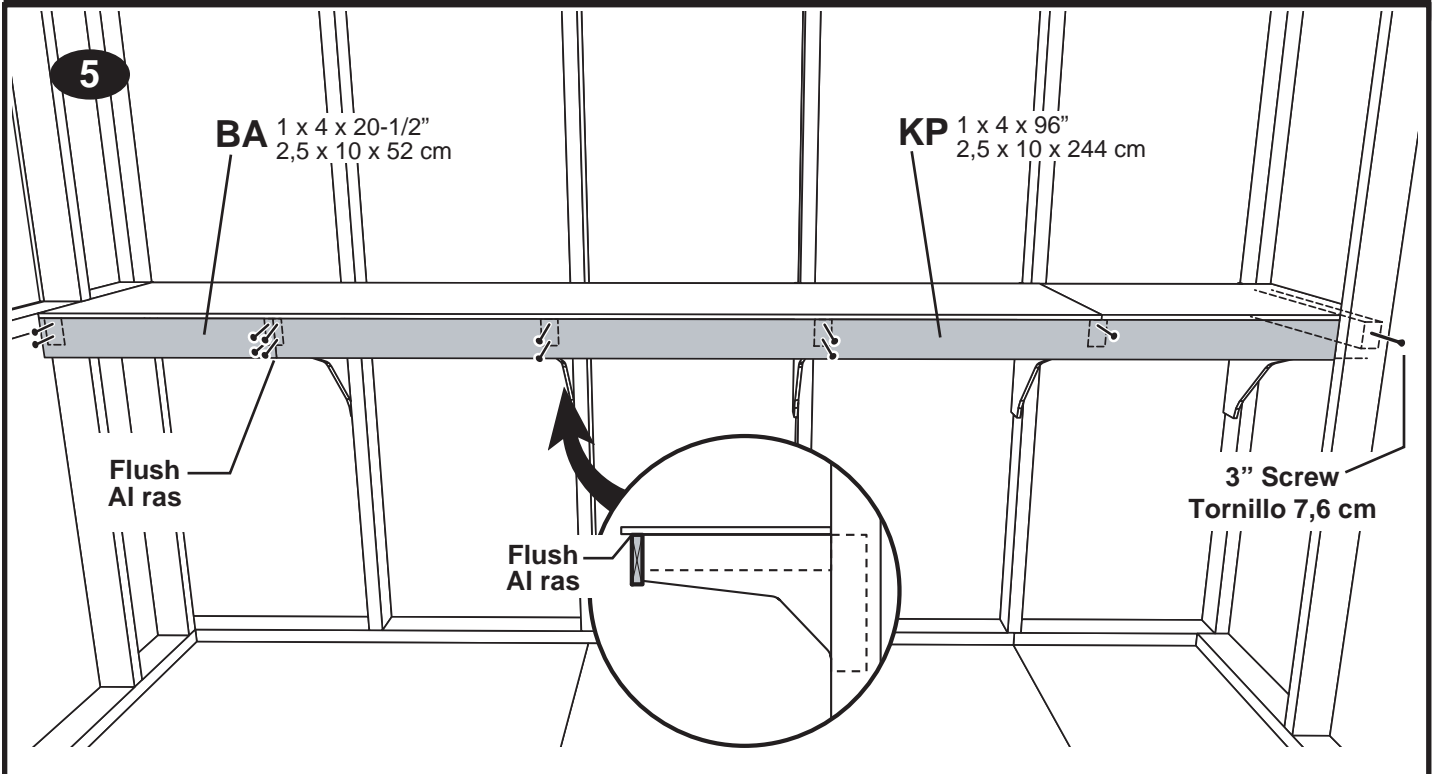

# BENCH

# BANCO

2" (5 cm)  
x 21

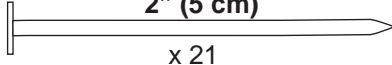

6

P-1

P-2

When installing pegboard, ensure bottom edge of pegboard is in contact with top of bench.  
 Al instalar pegboard, asegúrese que el borde inferior del pegboard está en contacto con la tapa del banco.

# SHELF

# ESTANTE

2" (5 cm)  
x 14

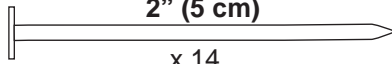

1

Assemble shelf frame on a flat surface.  
 Monte el marco del estante en una superficie plana.

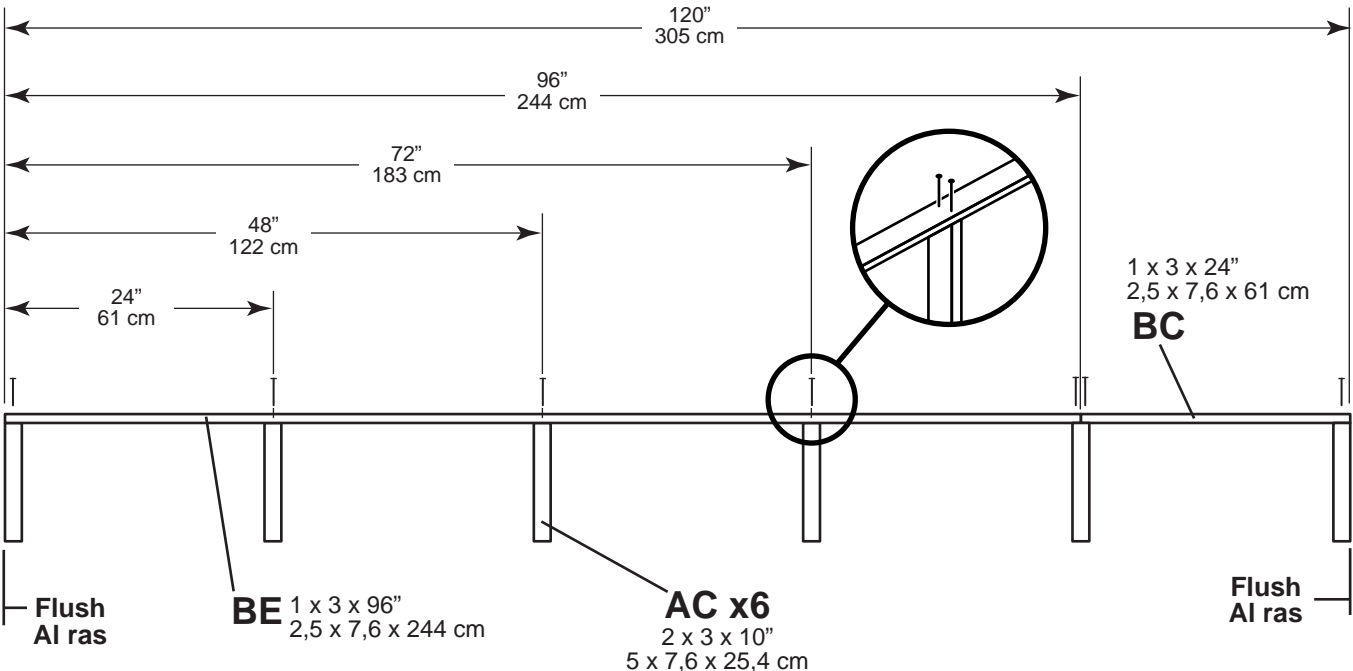



SHELF

3" (7,6 cm)

x 12

ESTANTE

2

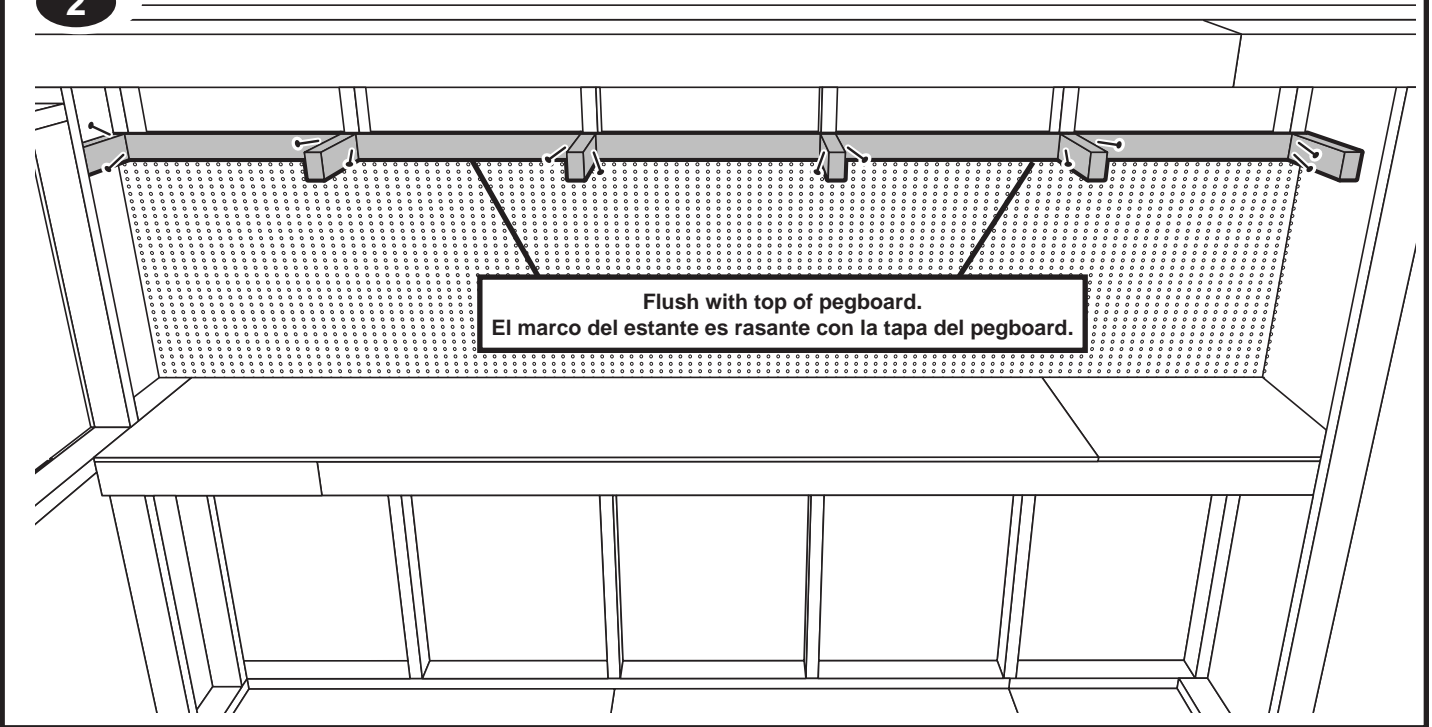

SHELF

1-1/4" (32 mm)

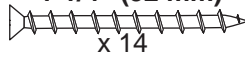

ESTANTE

3

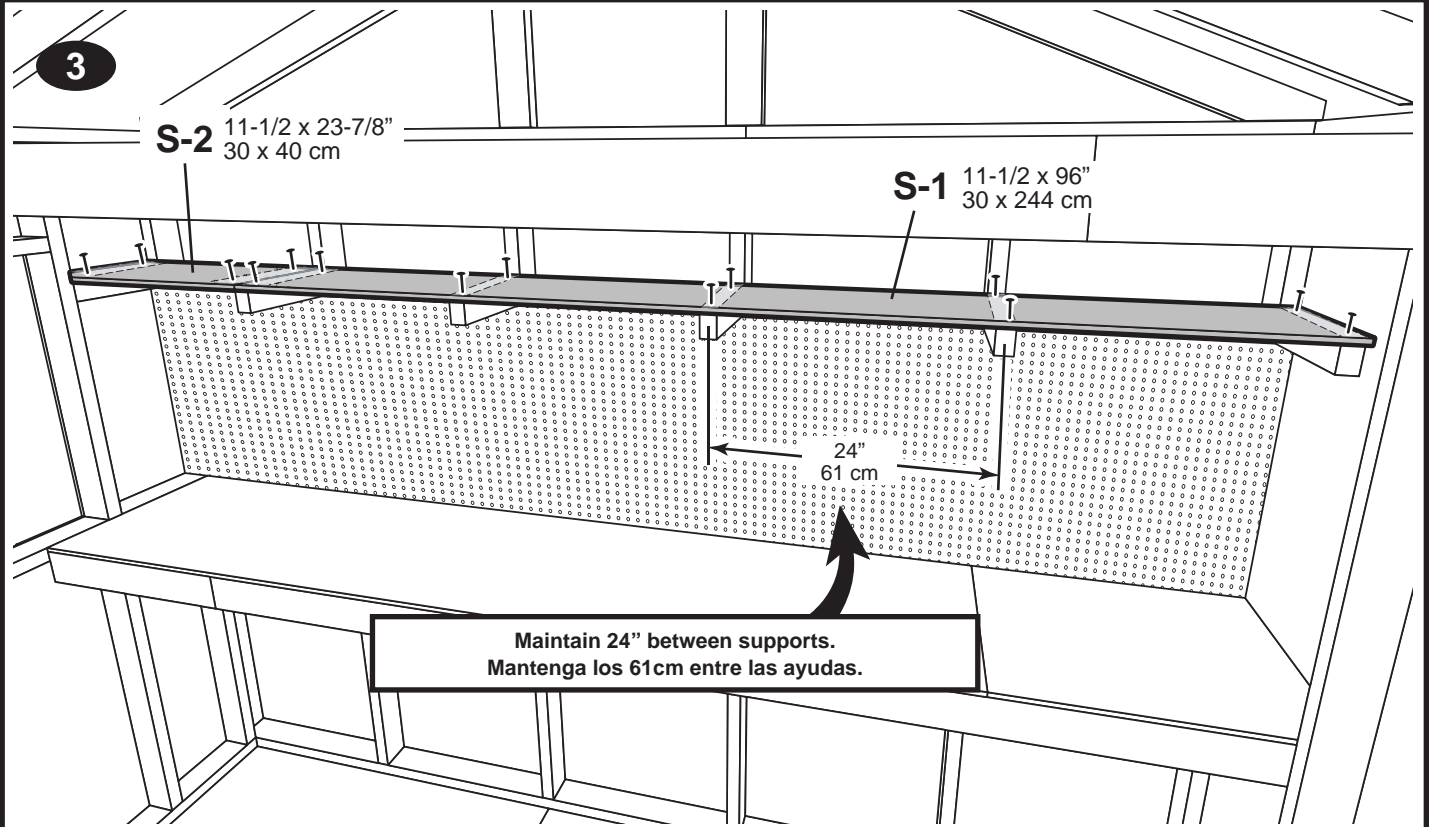

**SHELF**

**ESTANTE**

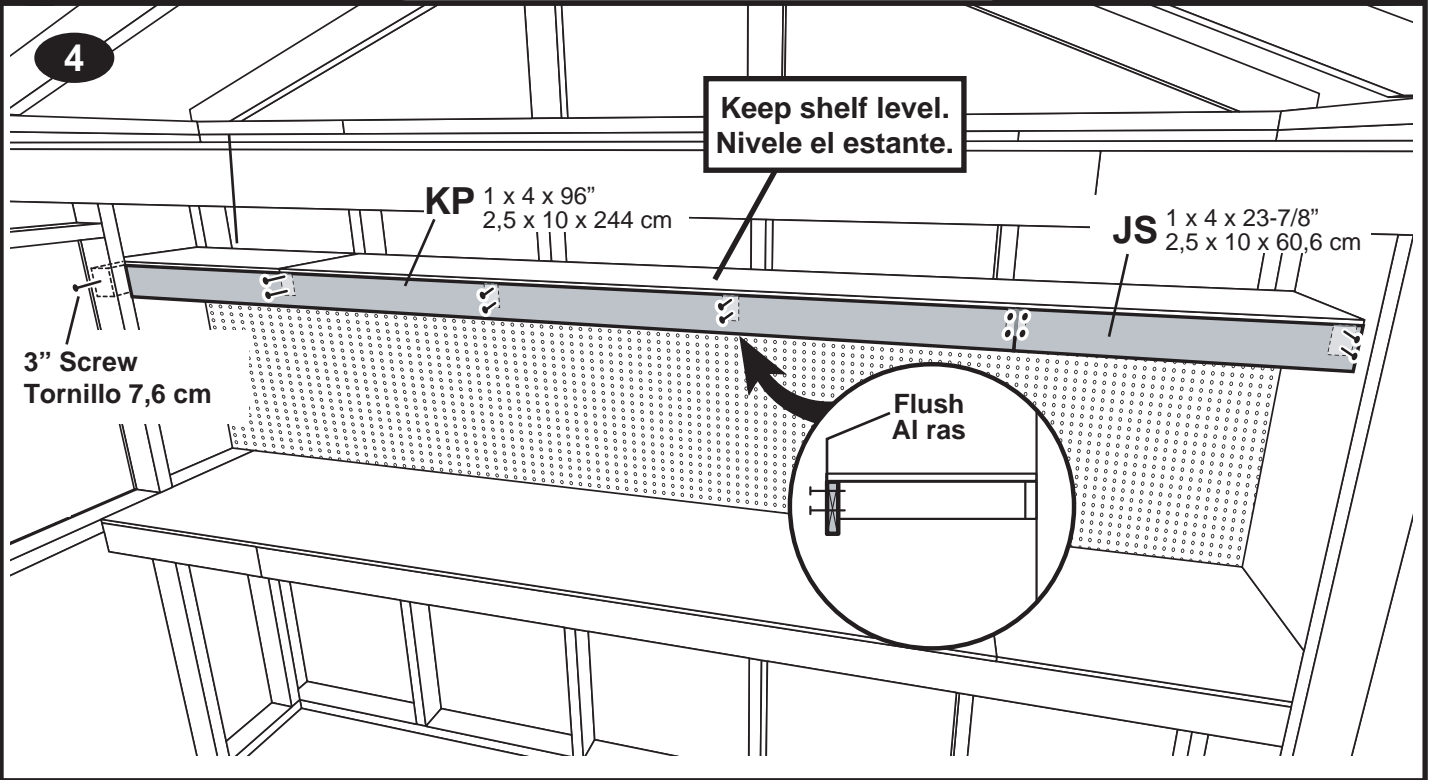
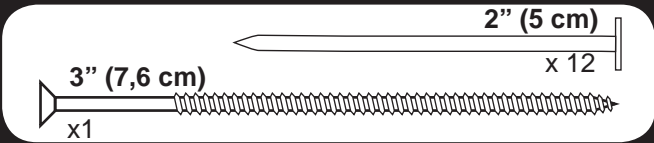

**SHELF**

**ESTANTE**

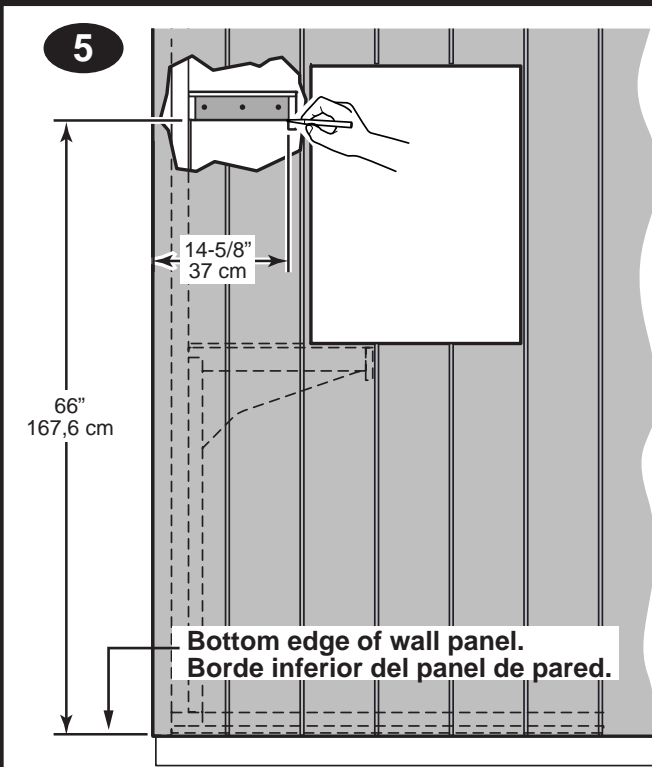
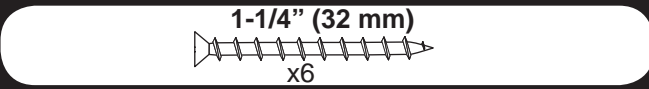

Repeat step 5 on back wall.  
Repita el paso 5 en la pared trasera.

**HINT:**  
Mark shelf support location on outside of panel.

**CONSEJO:**  
Marque la localización de la ayuda de estante en fuera del panel.

# LOFT

2" (5 cm)

x 30

# DESVÁN

1

- Install deck panels centered over loft joists and ledger board.
- Instale los paneles del desván centrados sobre las viguetas del desván y tablero de la ayuda del desván.

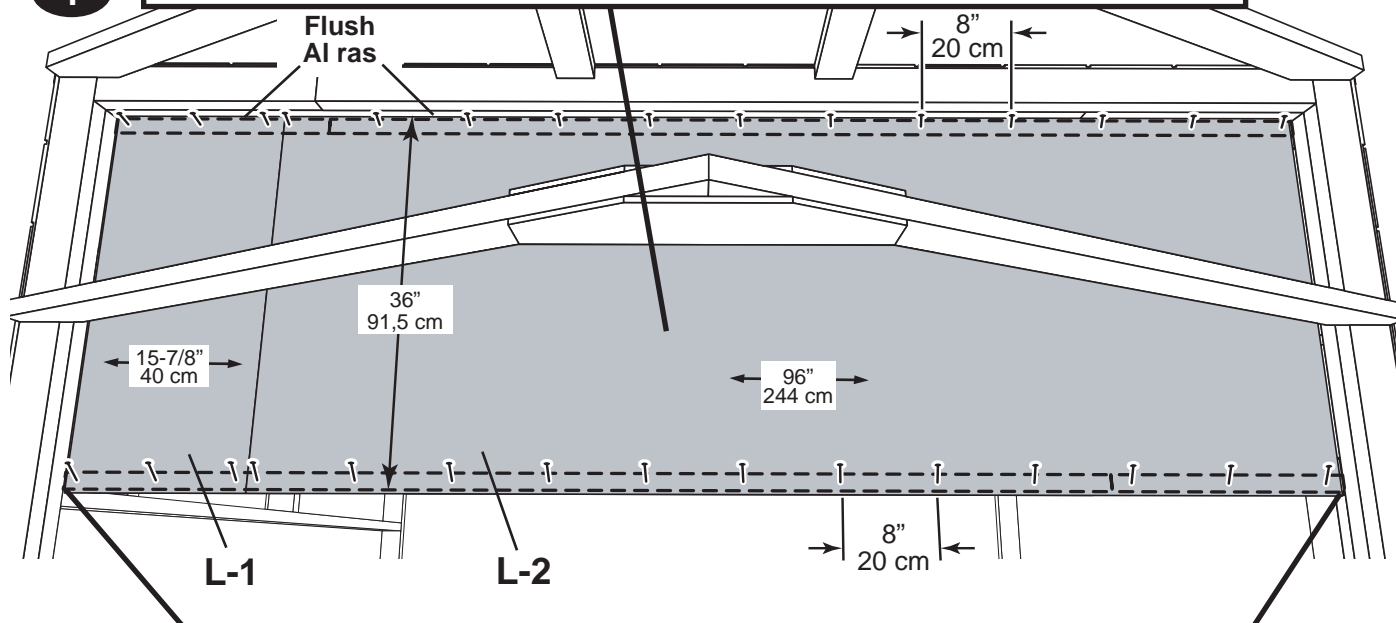

There will be a gap of approximately 1/2" on either side on either side of installed deck panels.  
Habrá un boquete de aproximadamente 13 mm en cada lado de los paneles del desván después de instalar.

# LOFT

2" (5 cm)

x 12

# DESVÁN

2

- Make three loft joist assemblies as shown.  
Haga a tres ensamblajes del vigueta para el desván como se muestra.

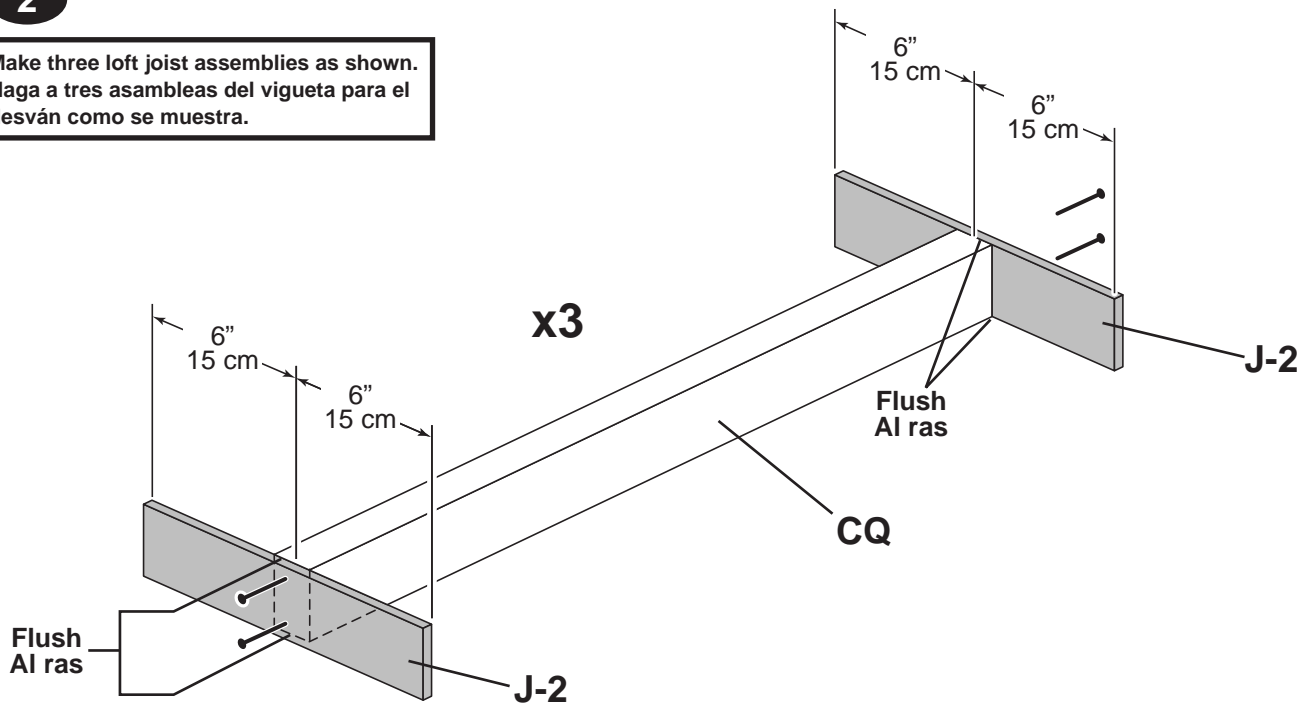

LOFT

2" (5 cm)

x 24

DESVÁN

3

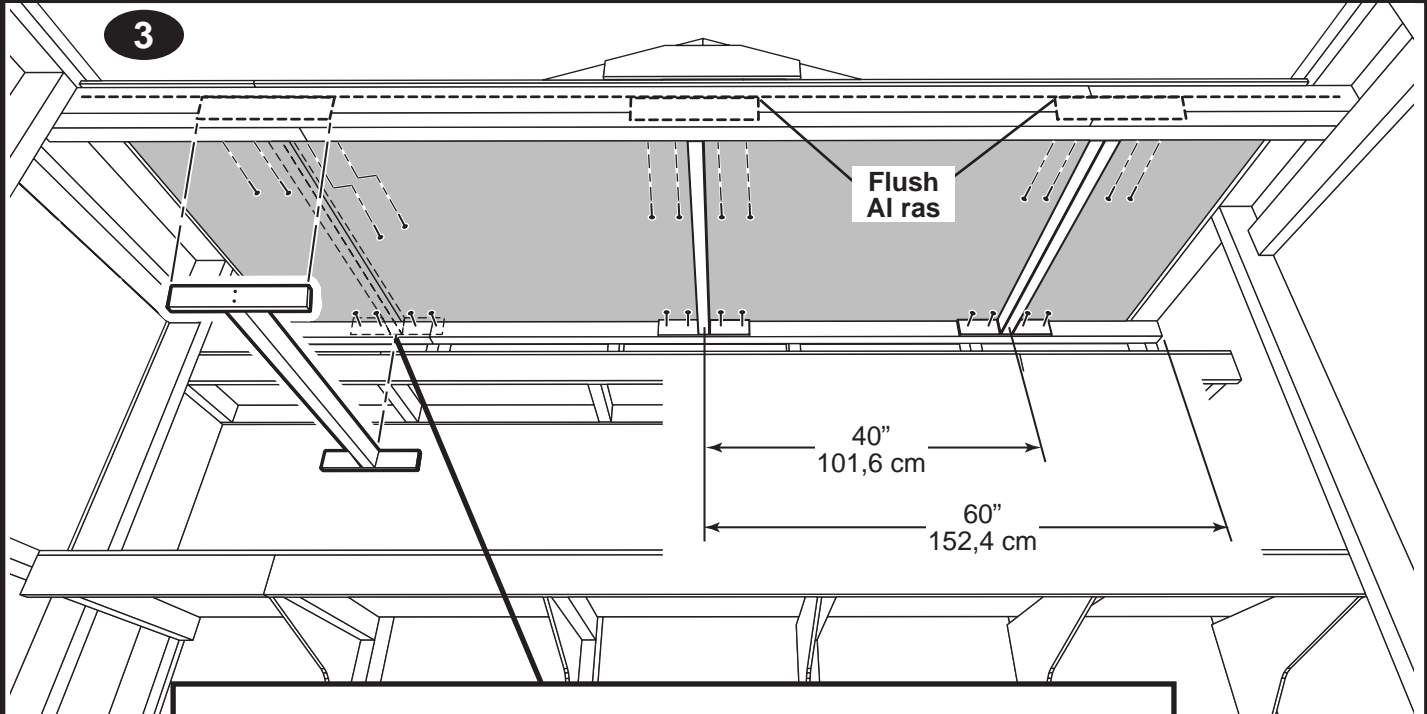

Install this loft joist assembly centered beneath loft panel seam.  
 Instale este vigueta del desván centrado por debajo el empalme entre los paneles del desván.

LOFT

2" (5 cm)

x 12

DESVÁN

4

Complete the loft installation by nailing through the loft panels into the three loft joist assemblies.  
 Termine la instalación del desván clavando a través de los paneles del desván en las tres viguetas premontadas del desván.

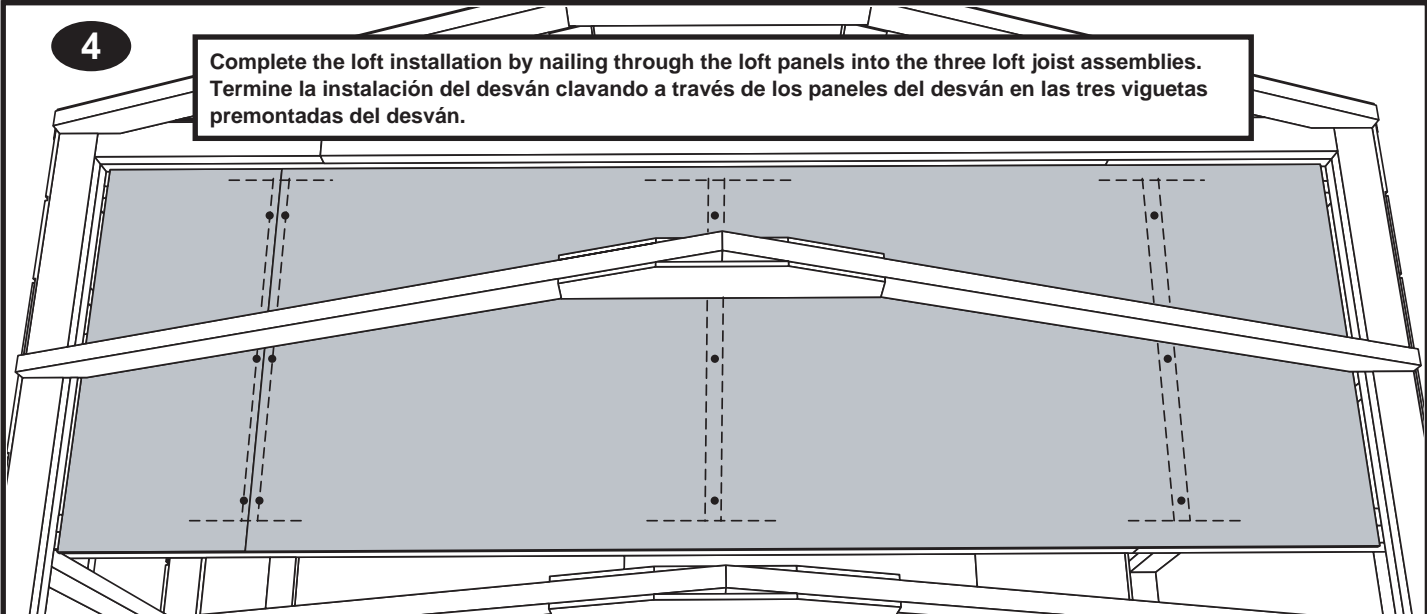

**Attention:**  
 Load not to exceed  
 400 lbs (181 kg) evenly  
 distributed across loft.

**Atención:** Cargue para no  
 excederse 400 lbs (181 kg)  
 distribuyeron uniformemente  
 a través de desván.

**ROOF**

2" (5 cm)

x 112

**TECHO**

**1**

See Page 7 for Building Tip!  
¡Vea la página 7 para el consejo de la construcción!

Flush  
Al ras

- Maintain truss dimension.
- Mantenga las dimensiones del armazón.

Center roof panel edges over rafters.  
Centre los bordes de los techo paneles sobre el vigas.

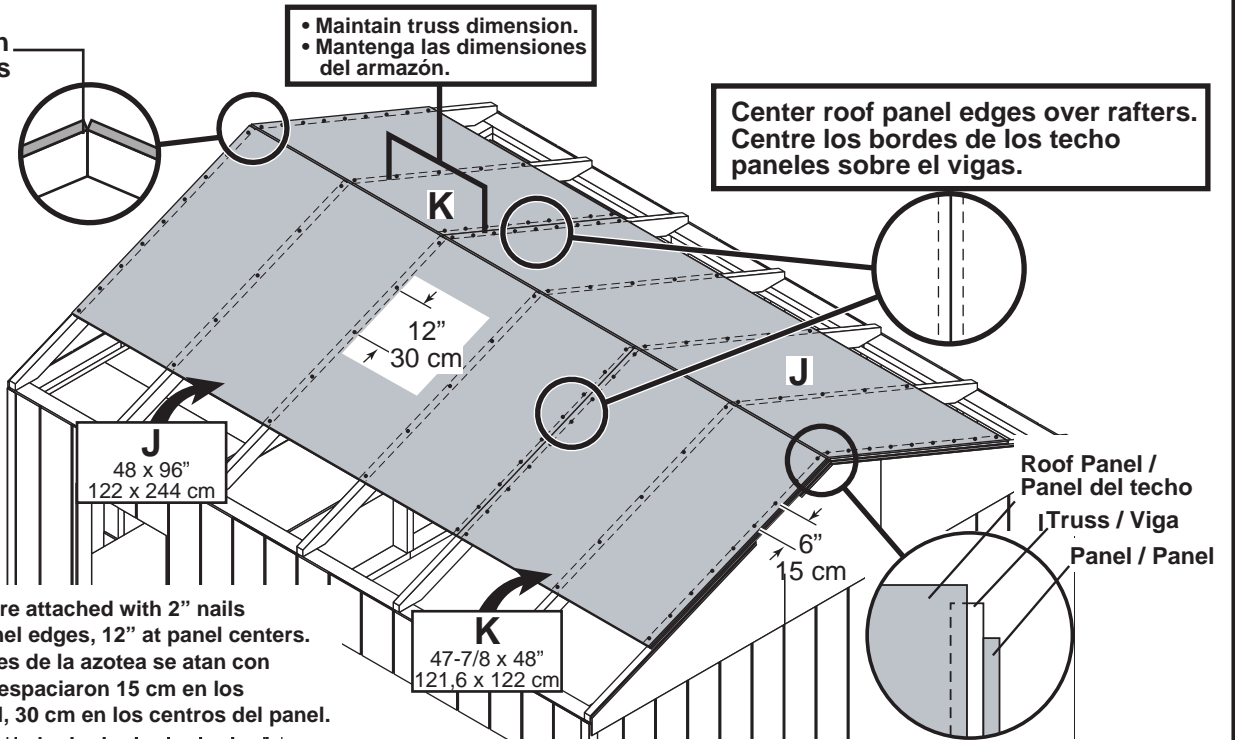

All roof panels are attached with 2" nails spaced 6" at panel edges, 12" at panel centers.  
Todos los paneles de la azotea se atan con los clavos 5 cm espaciaron 15 cm en los bordes del panel, 30 cm en los centros del panel.

**ROOF**

2" (5 cm)

x 56

**TECHO**

**2**

Install lower roof panels (L and M).  
Instale los paneles más bajos de la azotea (L y M).

See Page 7 for Building Tip!  
¡Vea la página 7 para el consejo de la construcción!

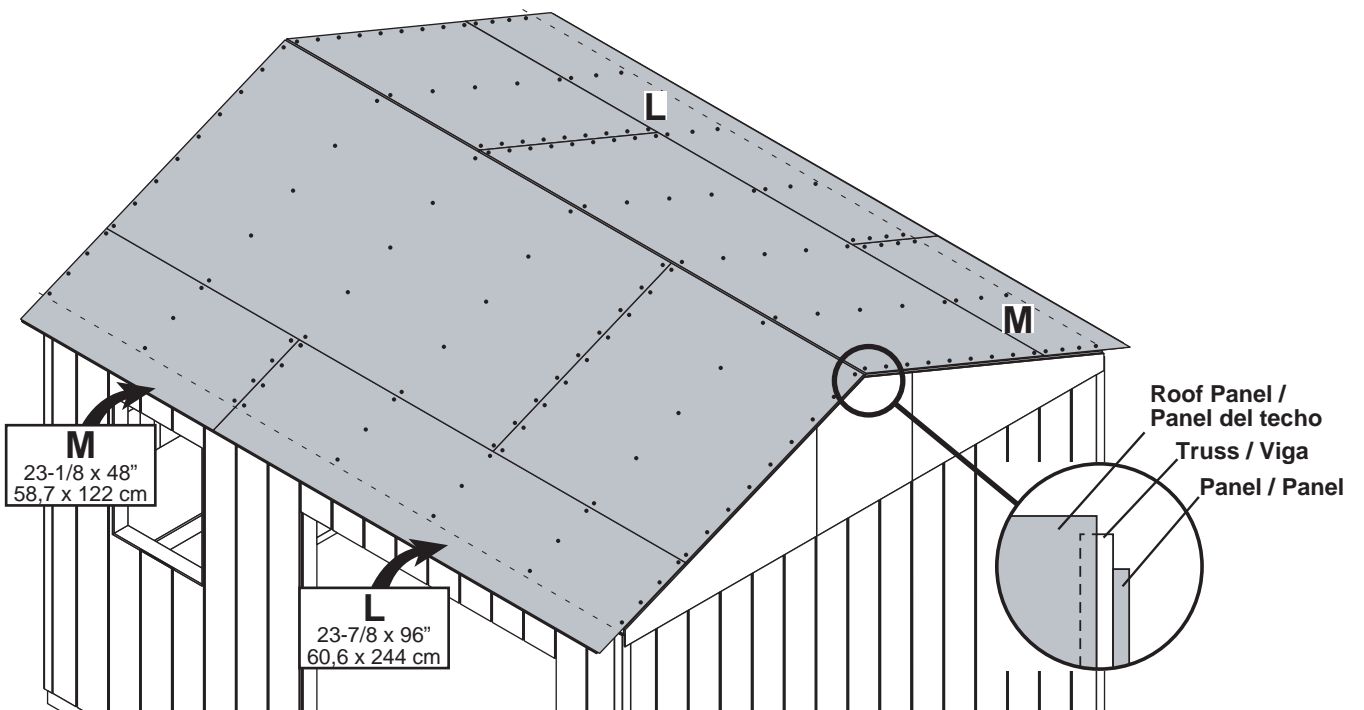

**ROOF**

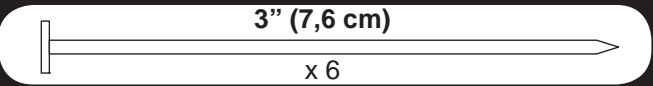

**TECHO**

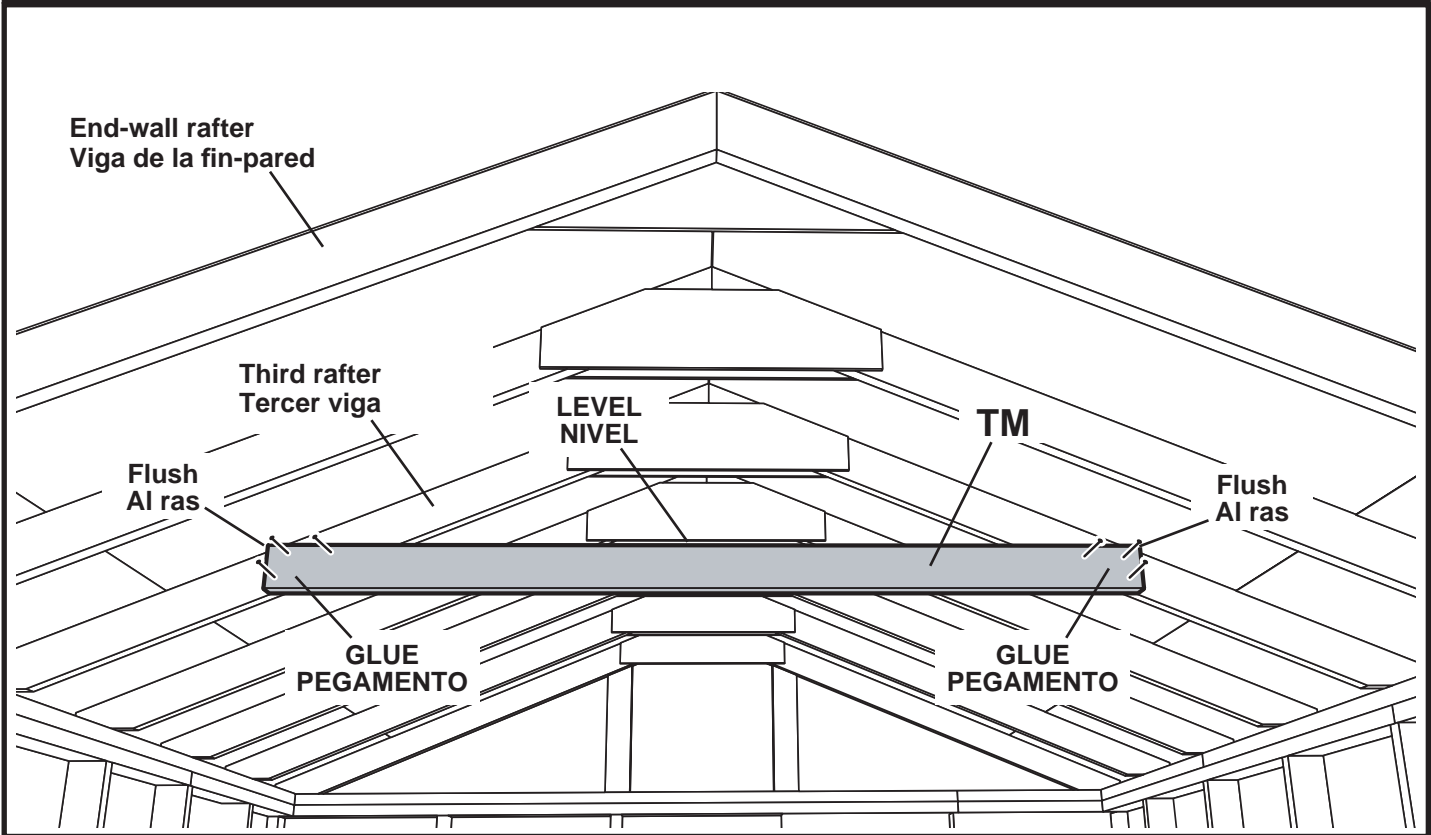

**TRIM**

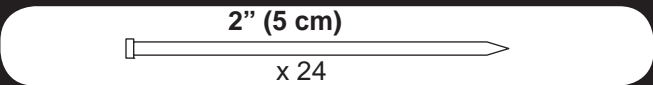

**MOLDURA**

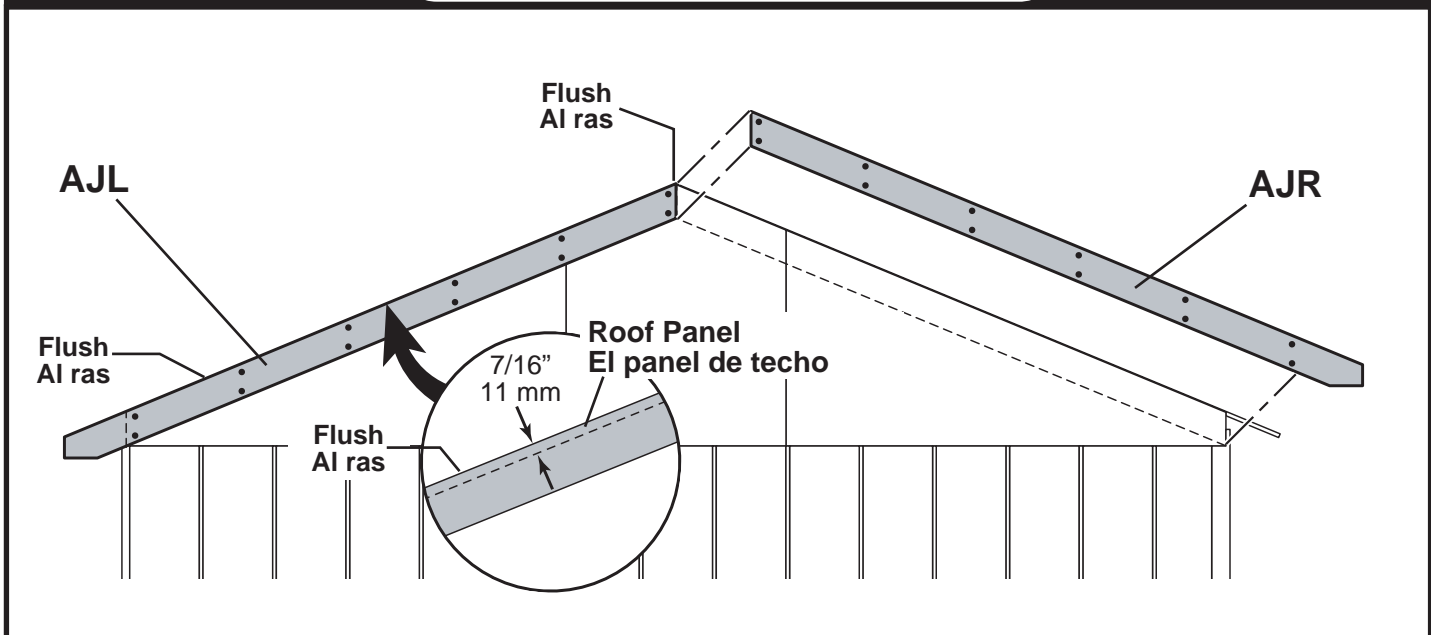

Trim parts should be flush with top of roof panels and flush at corners. Repeat installation at both gables.

Las piezas del moldeado deben ser rasantes con la tapa de los paneles de la azotea y también a ras en las esquinas. Repita la instalación de moldear en ambos aguilones.

TRIM

MOLDURA

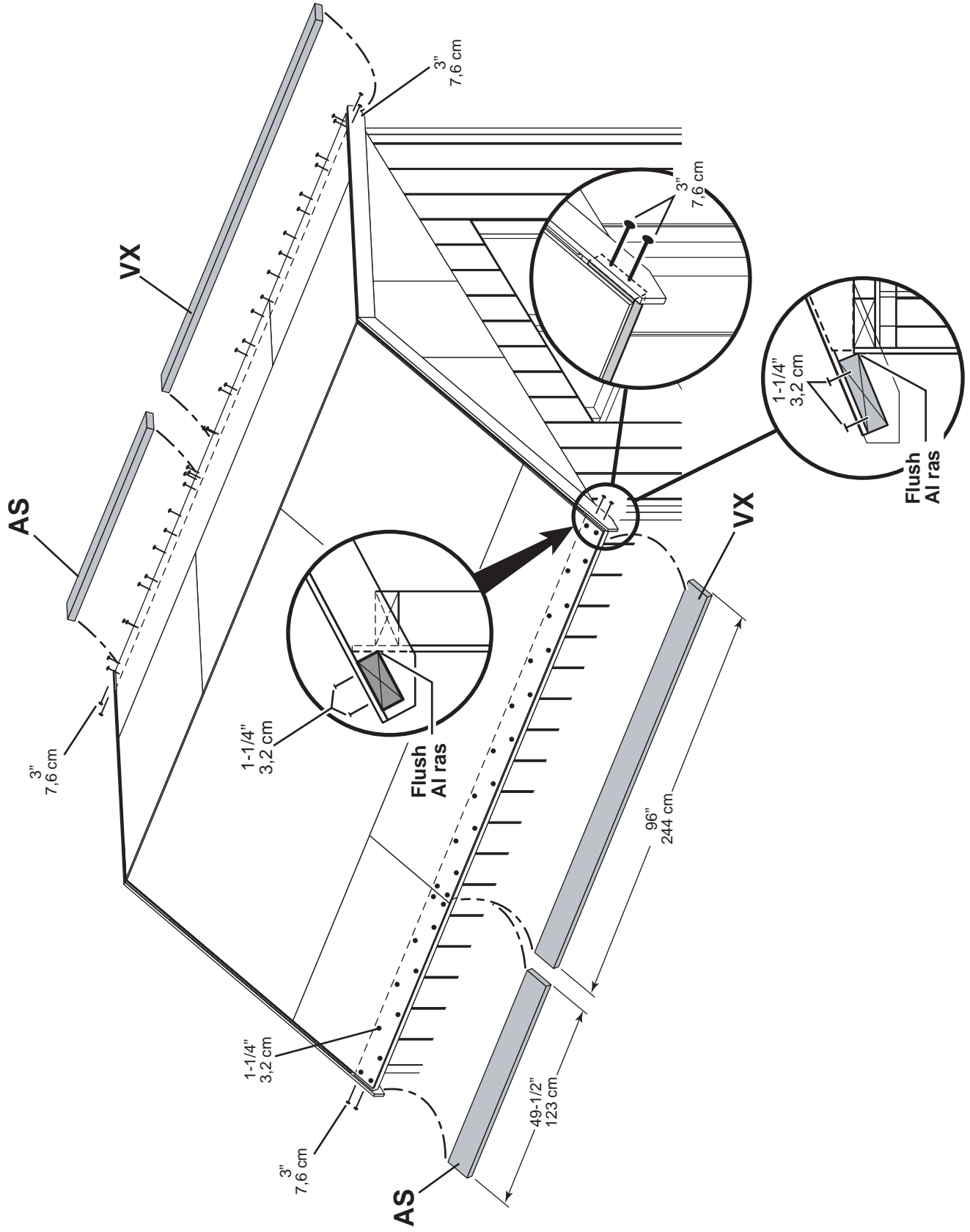
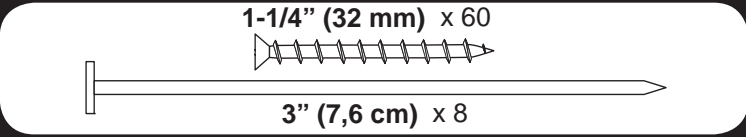



DOOR

PUERTA

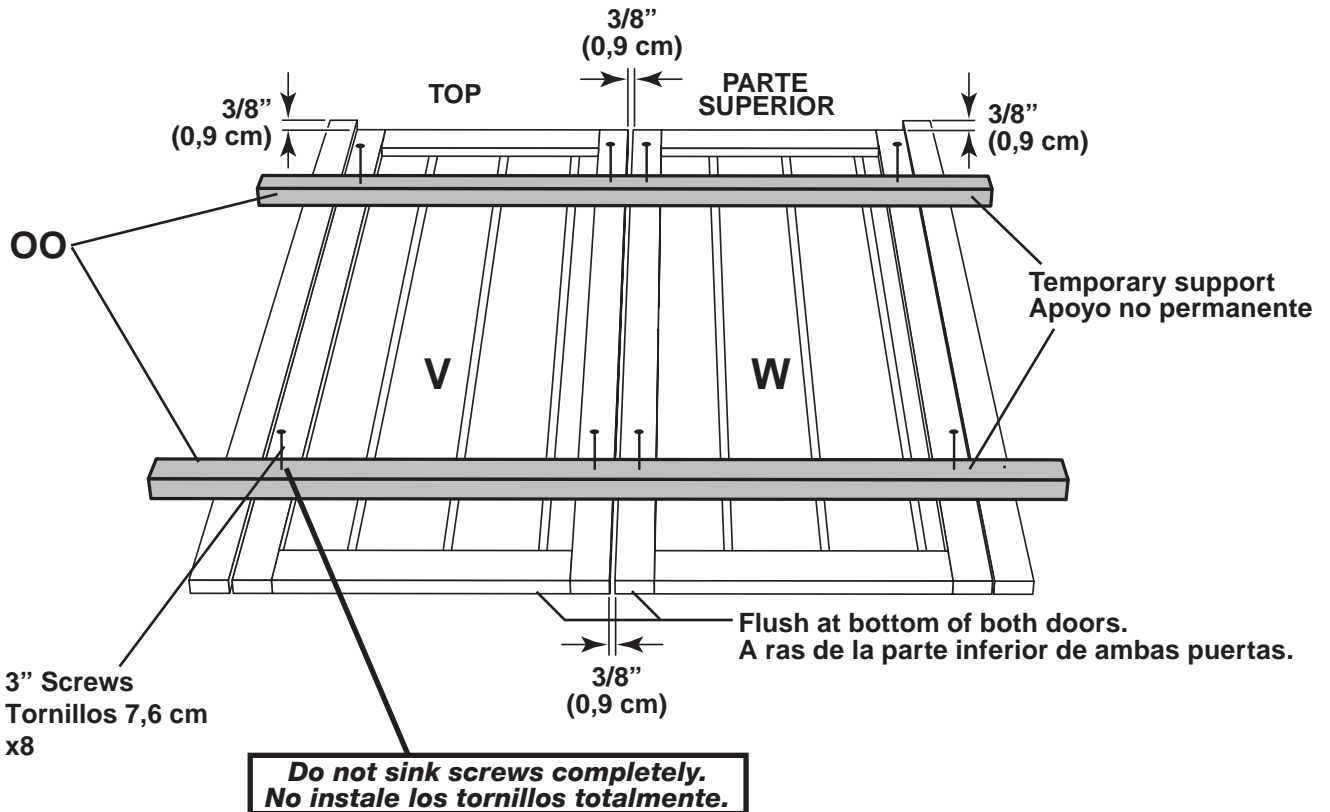
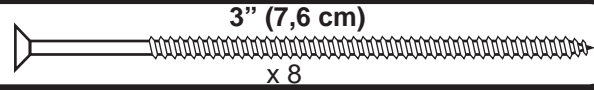

DOOR

PUERTA

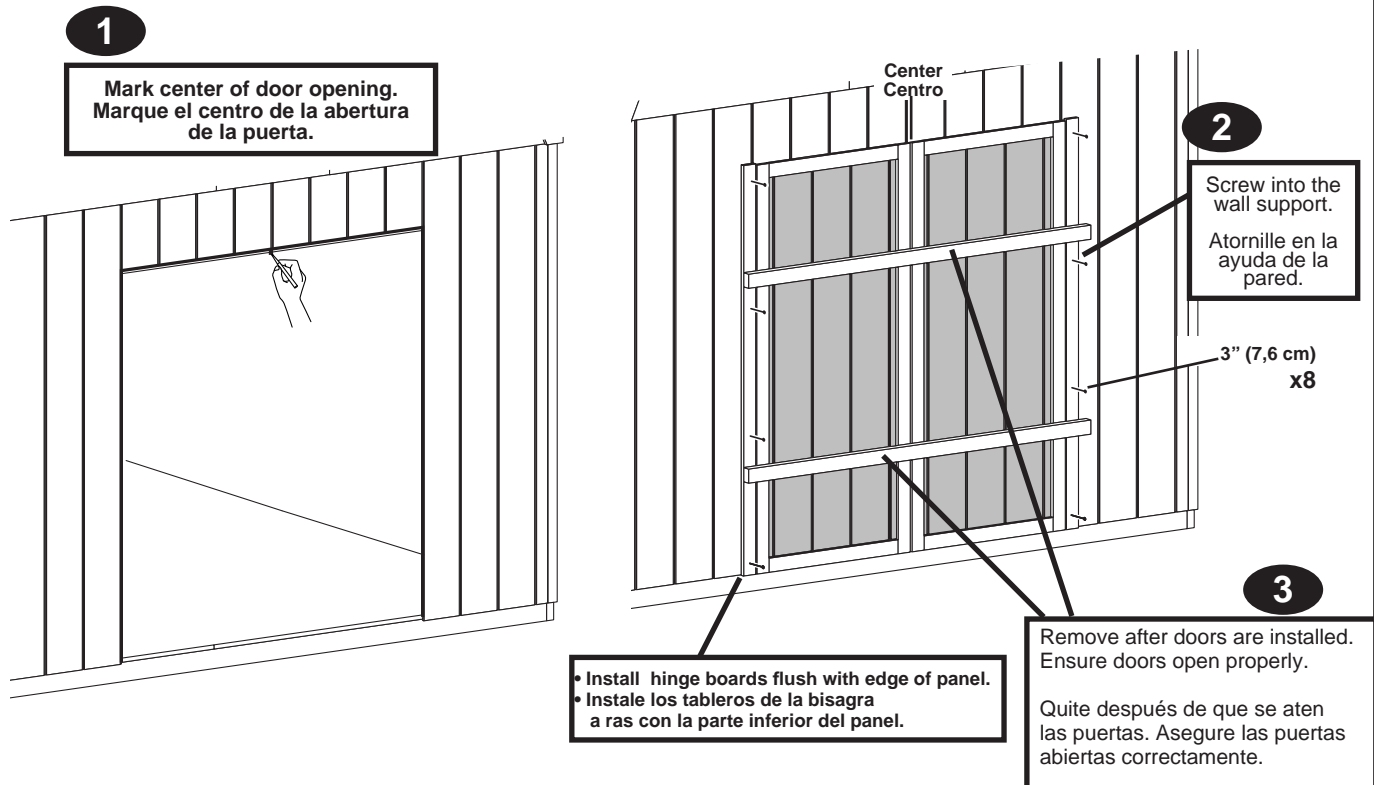
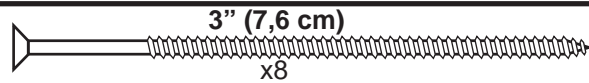



DOOR

PUERTA

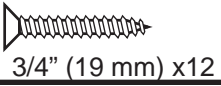
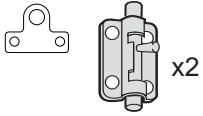
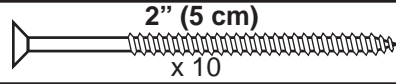

**OUTSIDE OF SHED  
FUERA DEL EDIFICIO**

**RIGHT DOOR  
PUERTA A LA DERECHA**

**LEFT DOOR  
PUERTA IZQUIERDA**

2" Screws  
5 cm Tornillos

OO

Install on left door.  
Instale en puerta izquierda.

Drill 3/8" Hole  
Taladro Hoyo (0,9 cm)

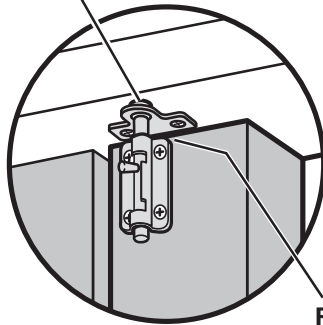

Flush  
Al ras

Drill 3/8" Hole  
Taladro Hoyo (0,9 cm)

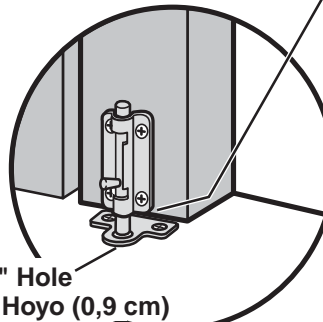

1-7/8" (4,7 cm)

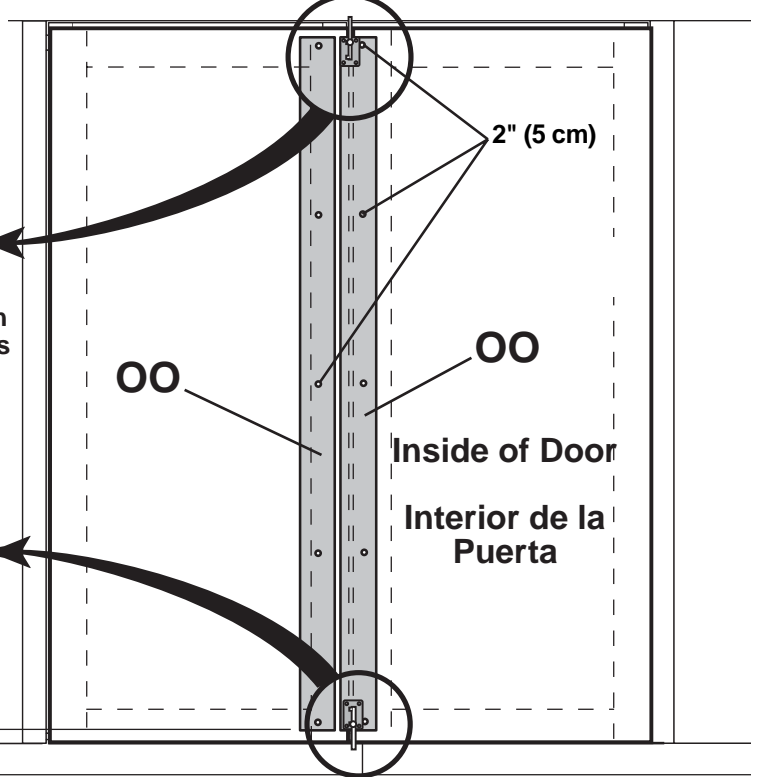

Bottom of door.  
Parte inferior de la puerta.

TRIM

3/4" (1,9 cm) x 22

2" (5 cm) x 7

MOLDURA

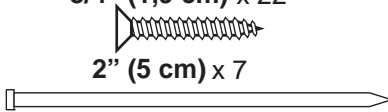

1

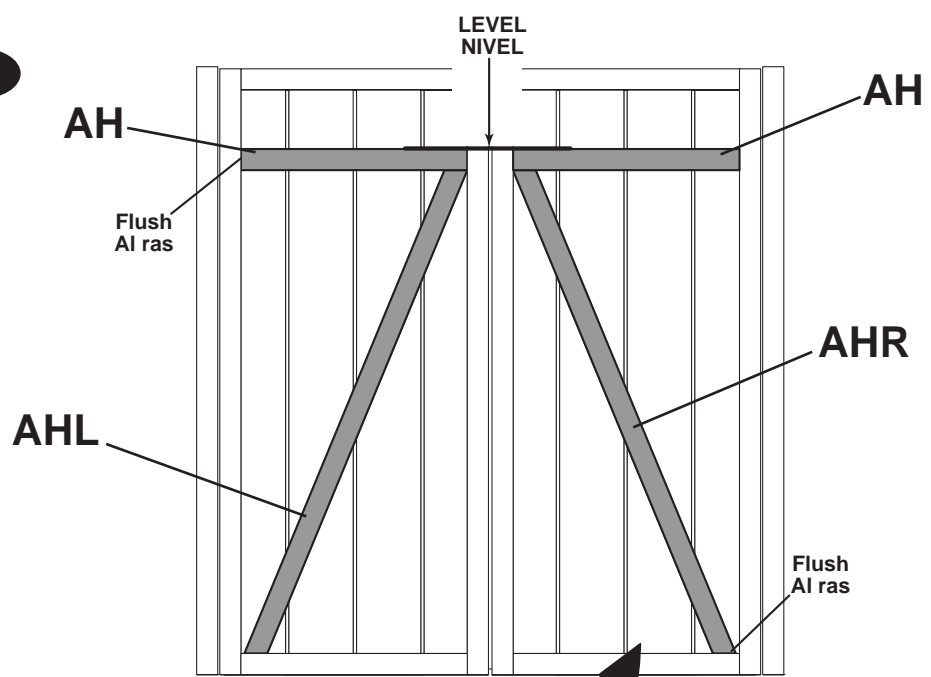

2

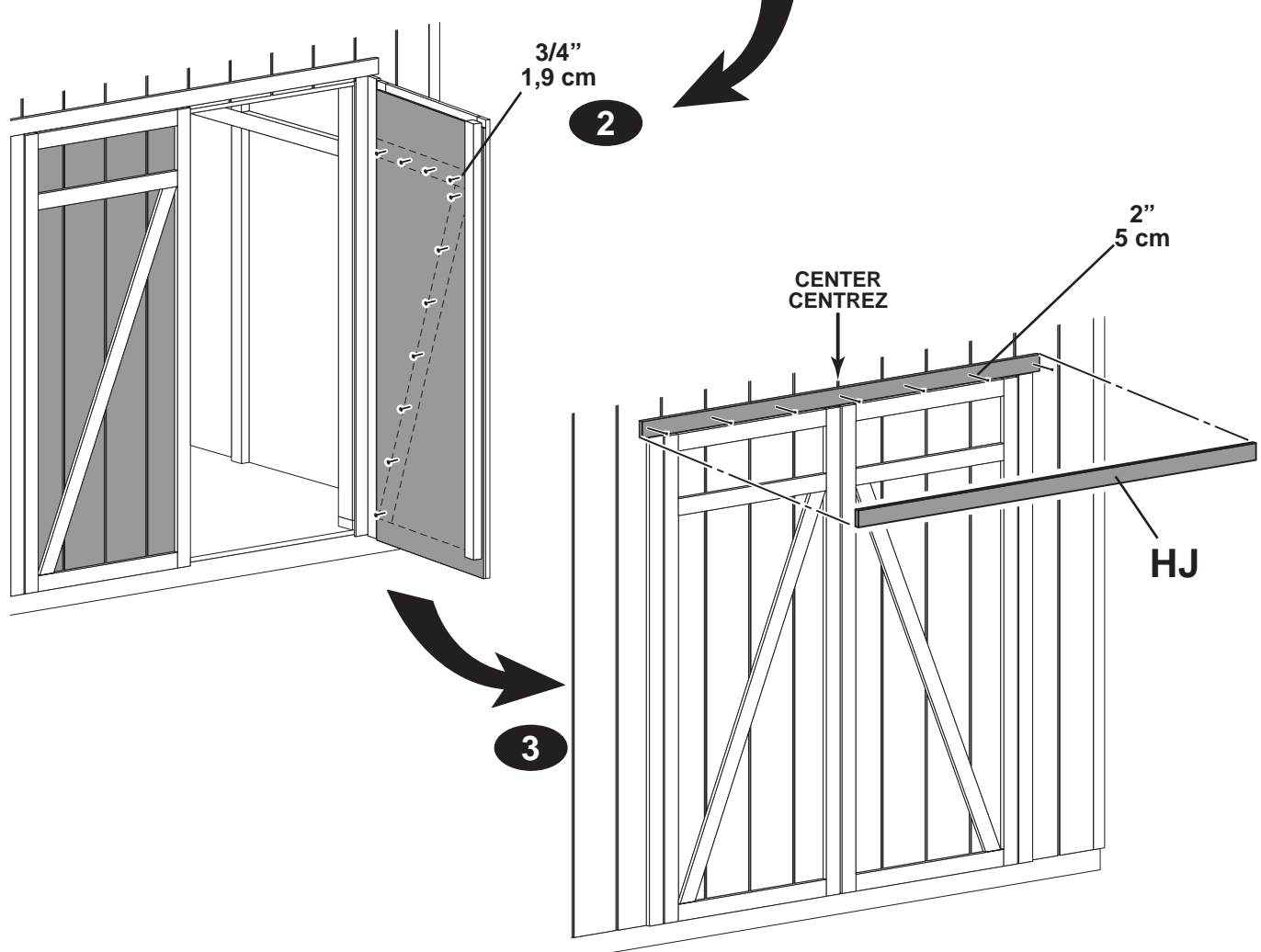

3



Install hinges (Z) centered on horizontal trim and flush against piano hinge.

Instale las bisagras (Z) centradas en ajuste horizontal de la puerta. El borde cuadrado de la bisagra está en contacto con la bisagra del piano.

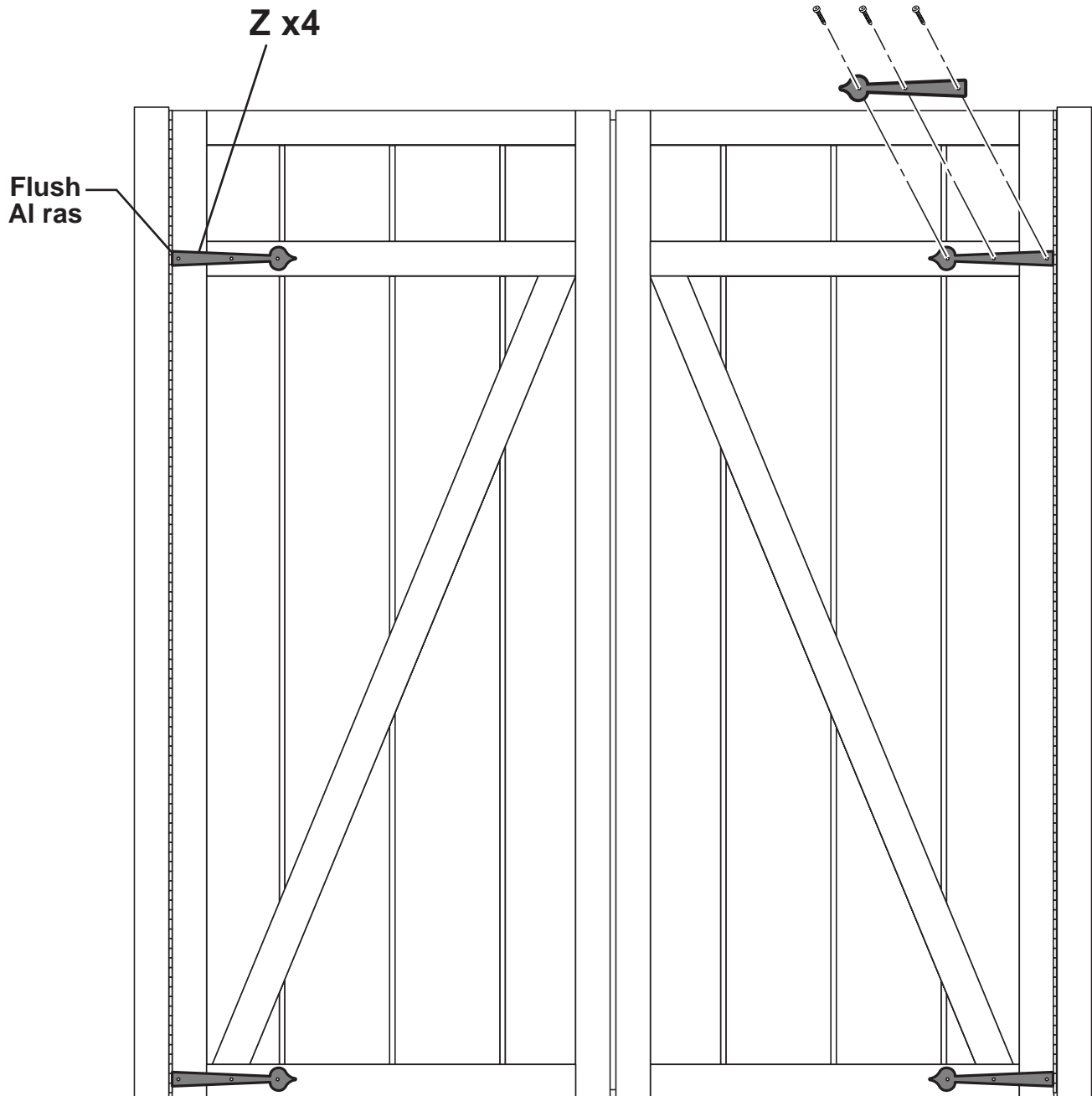

1

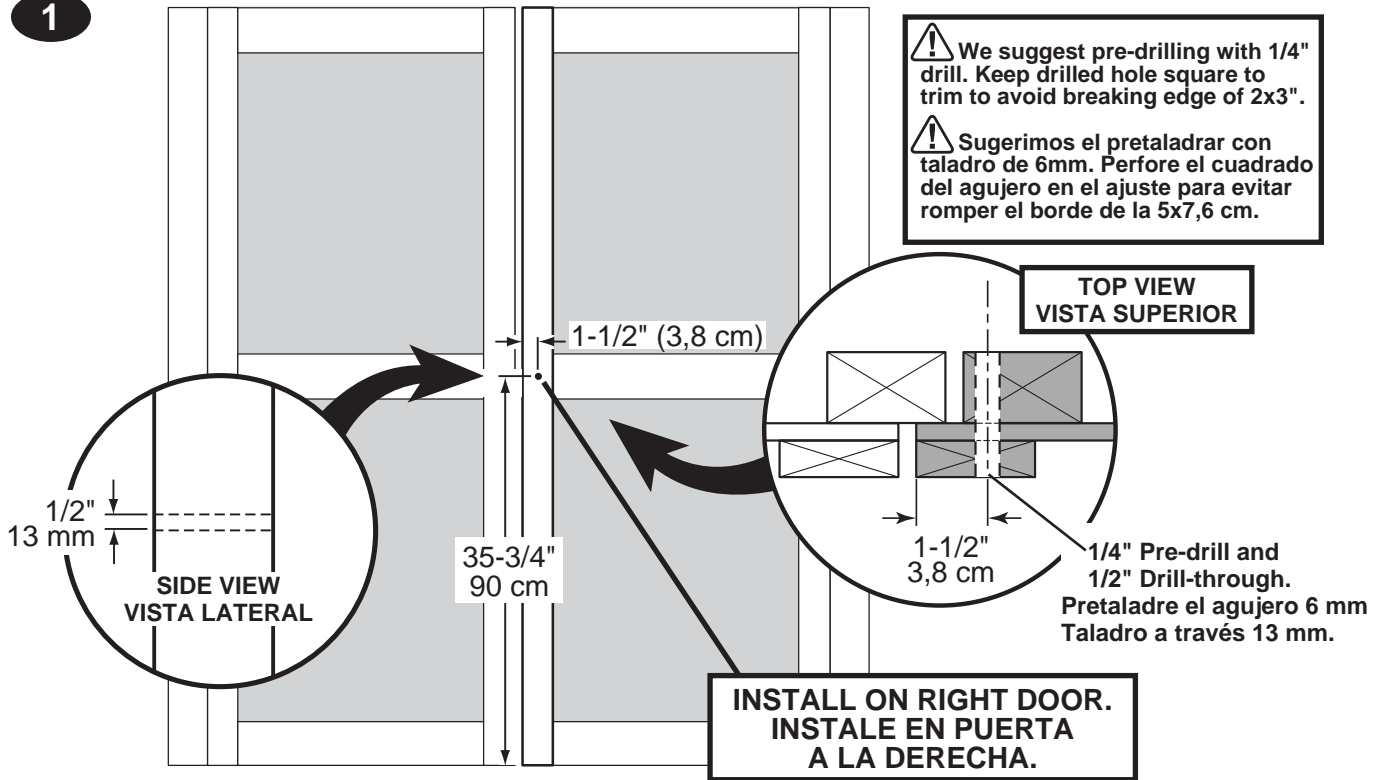

2

**SET SCREW  
TORNILLO DE PRESIÓN**

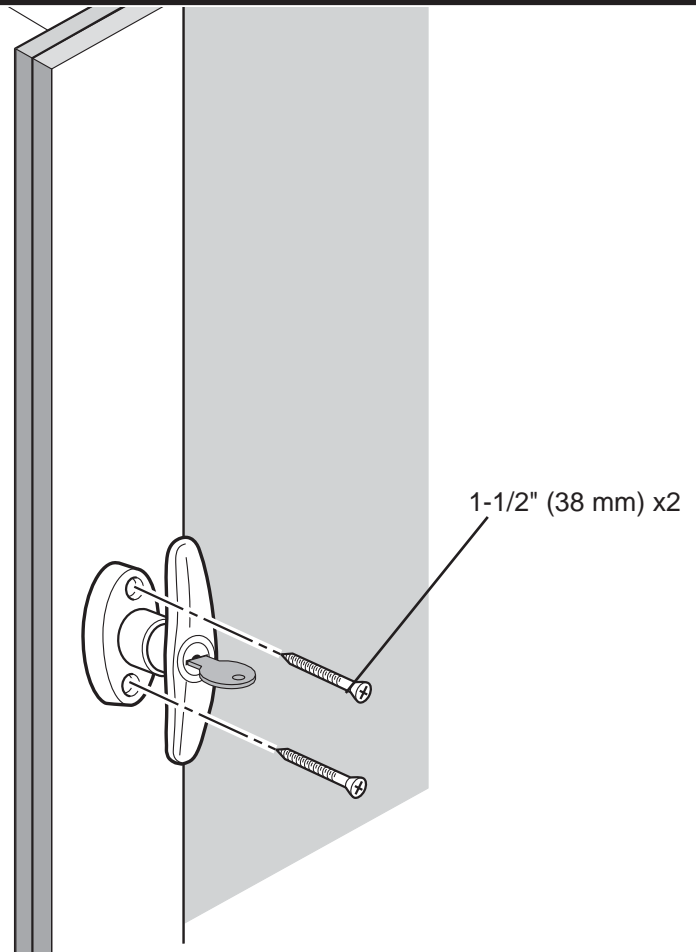
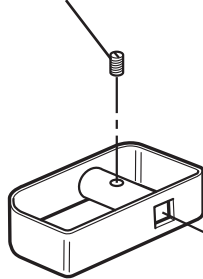

DOOR

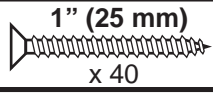

PUERTA

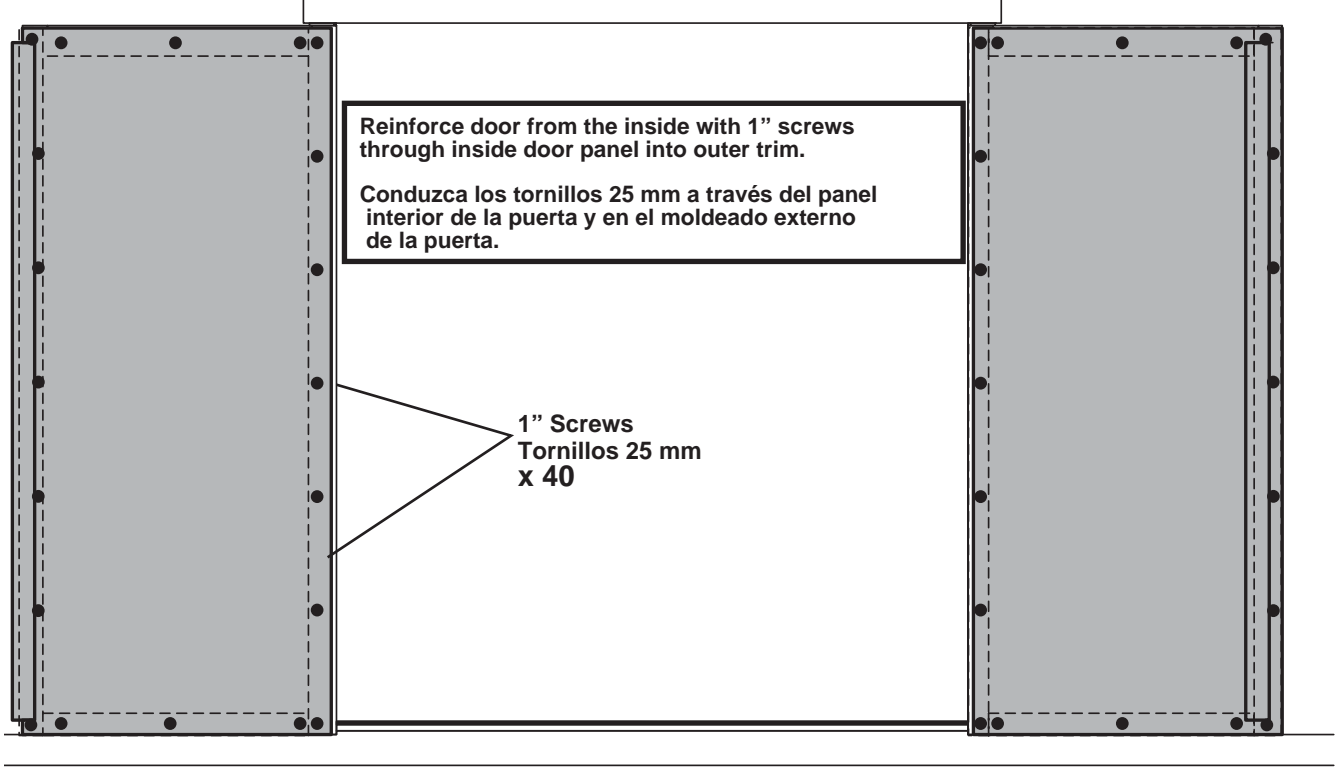

THRESHOLD

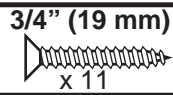

UMBRAL

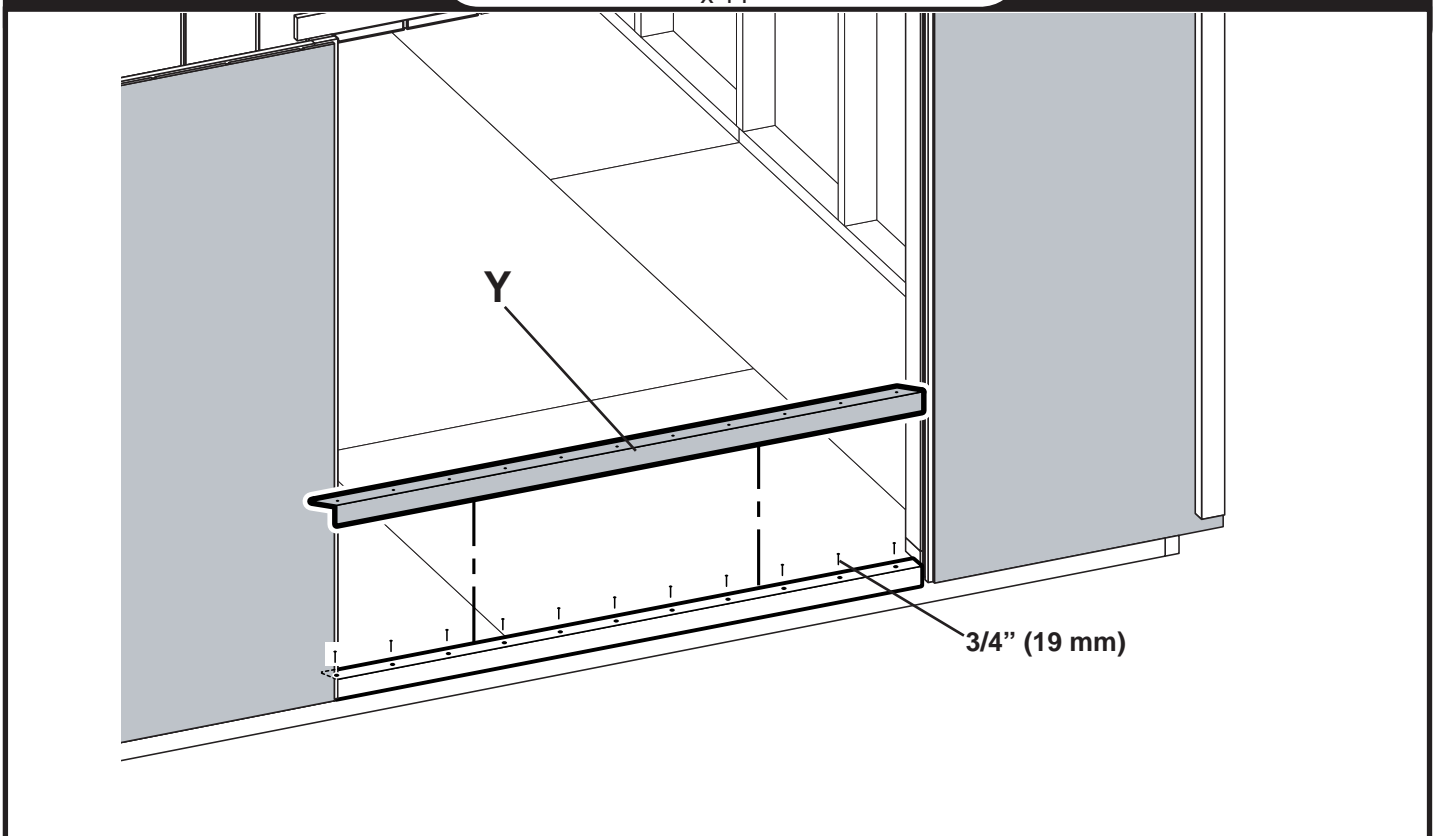

# SHUTTER ASSEMBLY

3/4" (19 mm)  
x 18

# ASAMBLEA DE POSTIGO

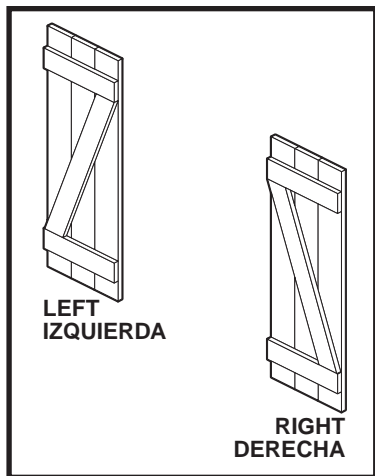
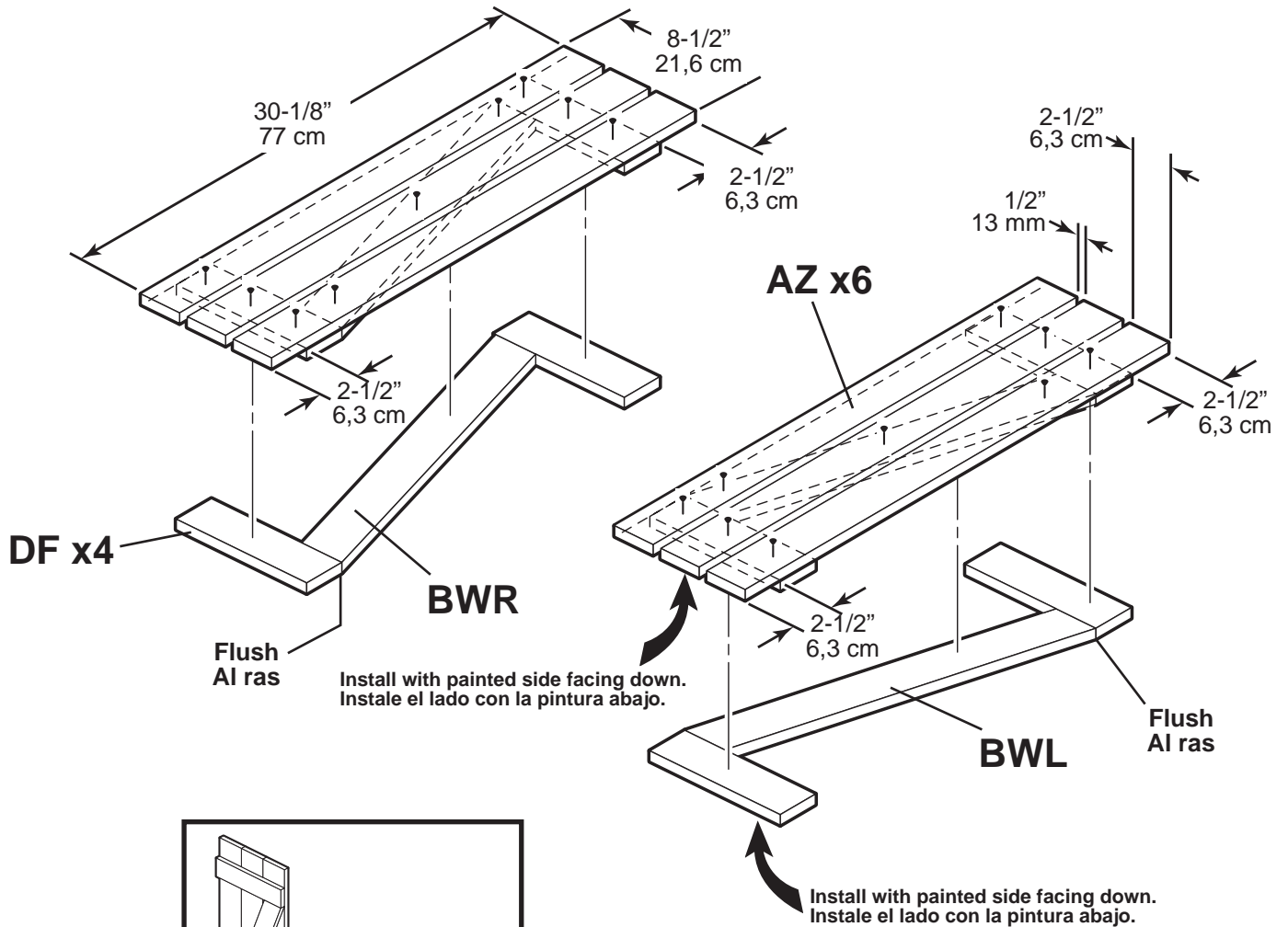

WINDOW

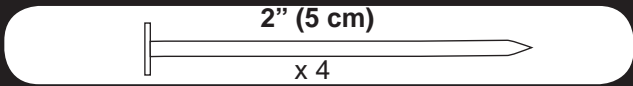

VENTANA

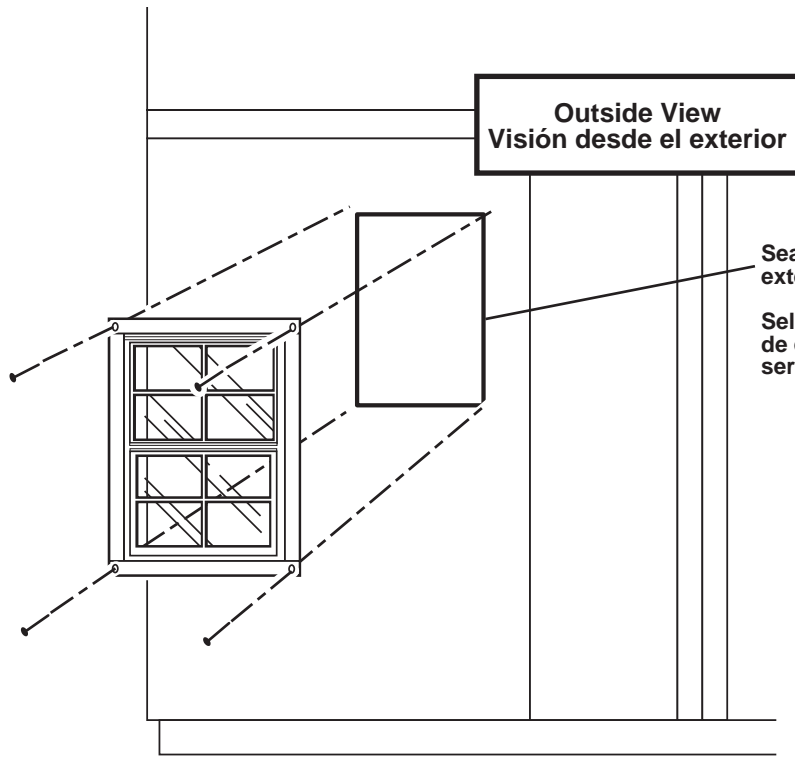

Seal window with high-quality paintable exterior-grade caulk.

Selle la ventana con el exterior-grado de calidad calafatean que puede ser pintado.

WINDOW

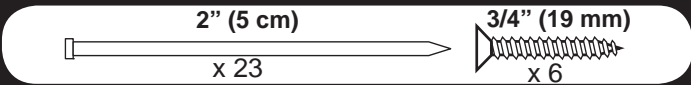

VENTANA

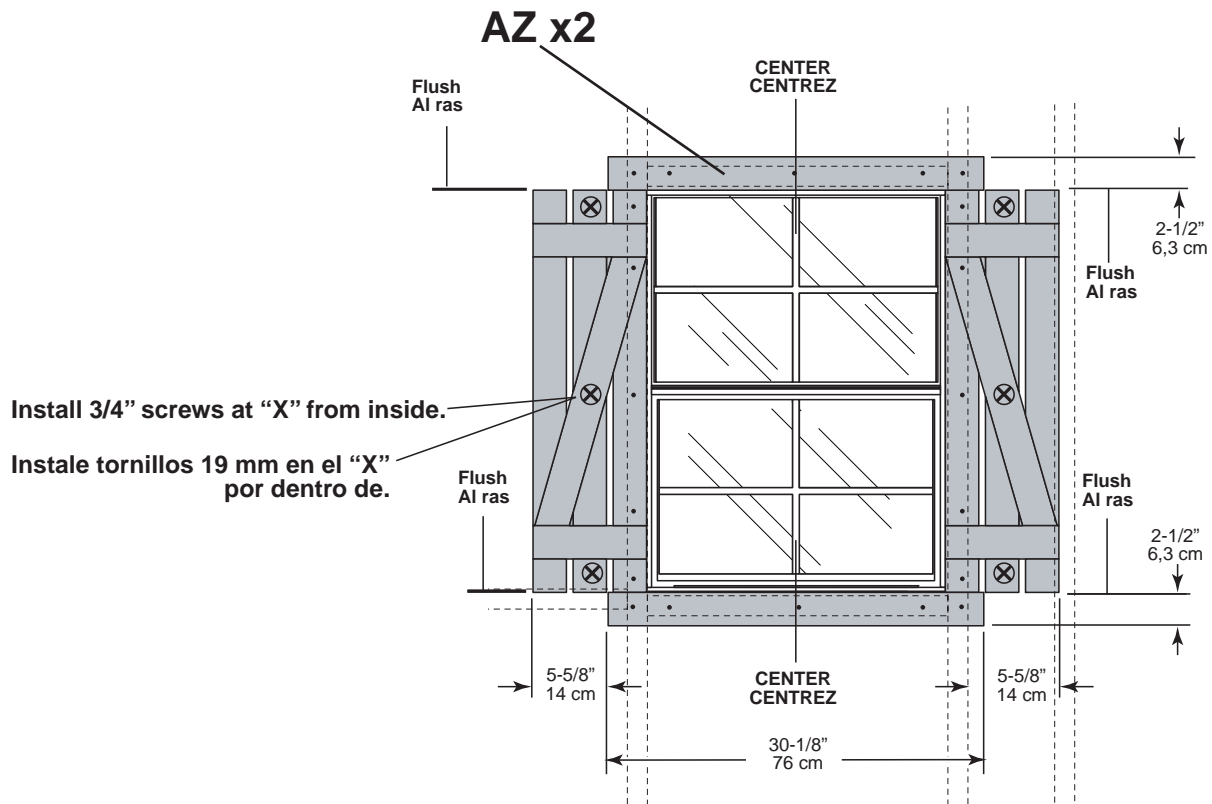

# VENT

1/2" (13 mm)



# RESPIRADERO

For optimum cross-ventilation install two vents.  
Vents should be installed on opposite walls.

Para la cruz-ventilación óptima instale dos respiraderos.  
Los respiraderos se deben instalar en las paredes opuestas.

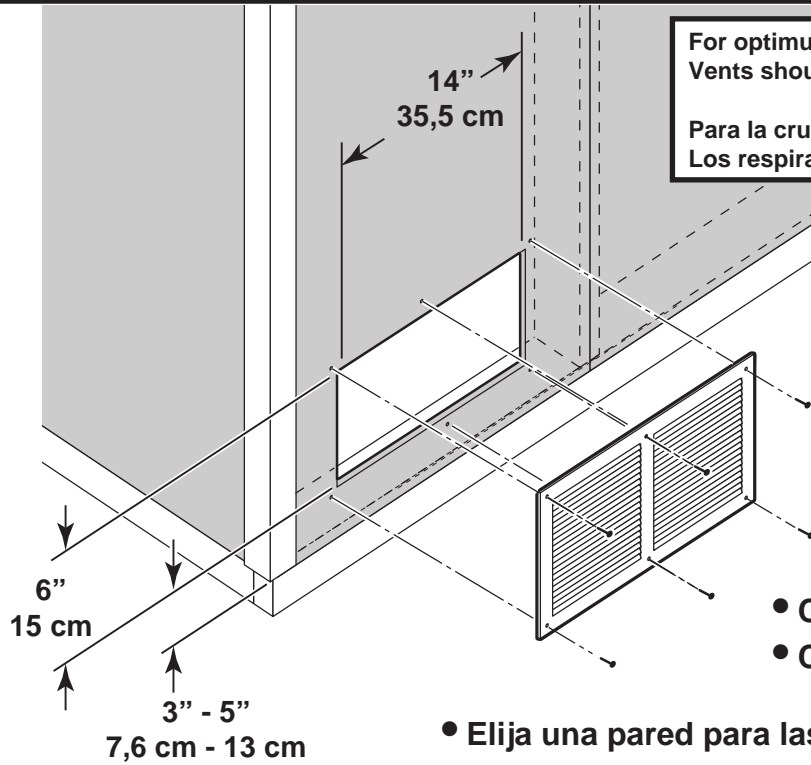

- Choose a wall for vent locations.
- Cut out wall panel as shown.

- Elija una pared para las localizaciones del respiradero.
- Corte los paneles de pared como se muestra.

# VENT

1/2" (13 mm)

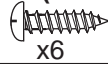

# RESPIRADERO

For optimum cross-ventilation install two vents.  
Vents should be installed on opposite walls.

Para la cruz-ventilación óptima instale dos respiraderos.  
Los respiraderos se deben instalar en las paredes opuestas.

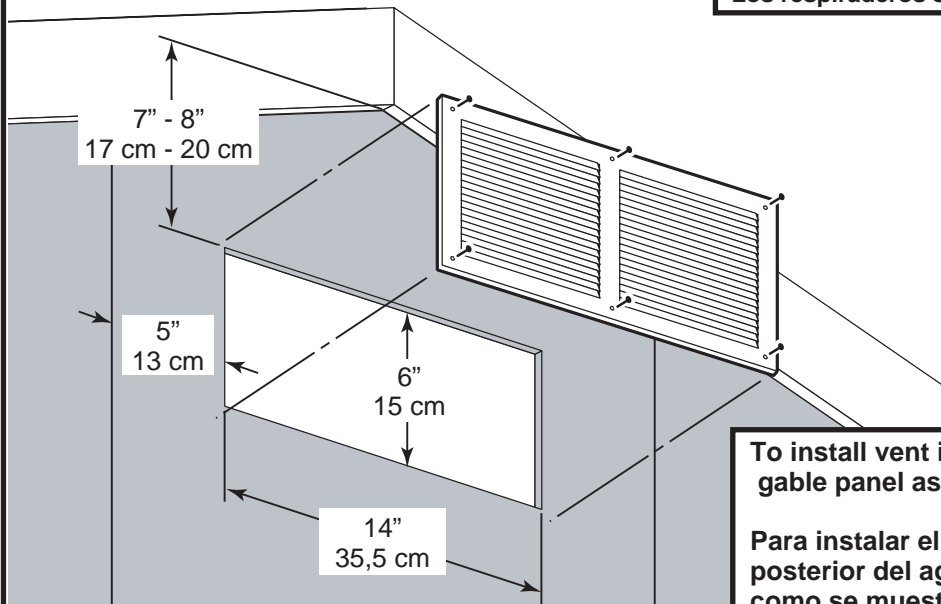

To install vent in rear center gable panel cut out gable panel as shown.

Para instalar el respiradero en el panel de centro posterior del aguilón corte el panel del aguilón como se muestra.



## PAIN T AND CAULK (Not Included)

Use Acrylic Latex Caulk that is paintable. Caulk at all horizontal and vertical seams, between the Trim and Walls, and all around the Door Trim.

Use a high quality exterior acrylic latex paint. When painting your building, there are a few key areas that can be easily overlooked that **must** be painted:

- Bottom edge of all siding and trim
- Inside of doors and all 4 edges

Note: Prime all un-primed exterior wood before painting

## PINTURA Y MASILLADO (No Incluidas)

Use masillado acrílico de latex pintable. Masille todas las costuras horizontales y verticales, entre la moldura y los muros, y alrededor de la moldura de la puerta.

Use pintura acrílica de látex de lata calidad. Al pintar su edificio, hay unas áreas claves que hay que pintar:

- Debajo de la moldura en las puertas.
- Debajo de la moldura de esquinas.
- Todo el exterior del edificio.
- Las partes interiores y superiores de las puertas y el borde superior de la cobertura.

Building Size Dimensiones del edificio	Building Paint Pintura del edificio	Trim Paint Pintura de moldura	Caulk Masillado
10' x 12' (305 x 366 cm)	2-1/2 Gallons/ galones	1 Quart/ cuartas	2 Tubes/ Tubos

## DRIP EDGE (Not Included)

## BORDE DEL GOTERO (No Incluidas)

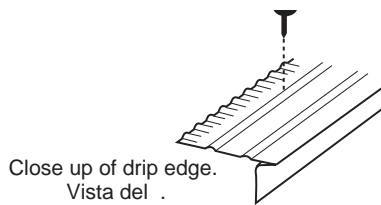

Side that hangs over side. No Nails.  
La parte que está colgada sobre un lado.  
Ningunos clavos.

Snip bottom side of drip edge and bend over to other side of roof.  
Corte la parte inferior del borde del gotero y dóblela sobre el otro lado del techo.

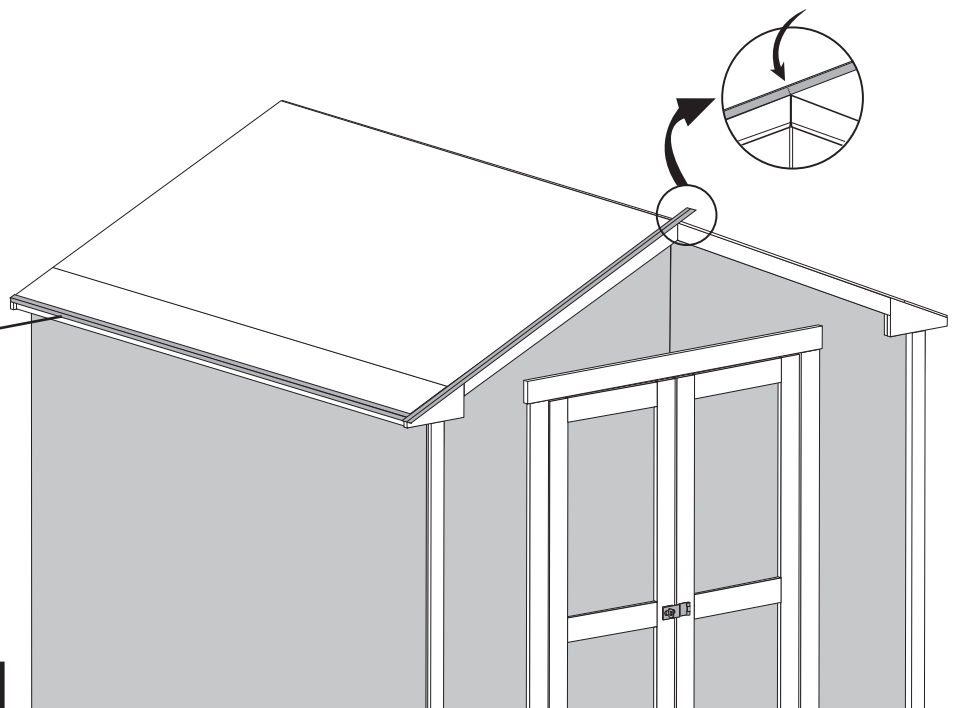

Building Size Dimensiones del edificio	Dripedge Borde del gotero
10' x 12' (305 x 366 cm)	60' 18 m

# SHINGLES (Not Included)

# TEJAS (No Incluidas)

Building Size Dimensiones del edificio	Shingles Needed Tejas necesarias
10' x 12' (305 x 366 cm)	6 Bundles/bultos

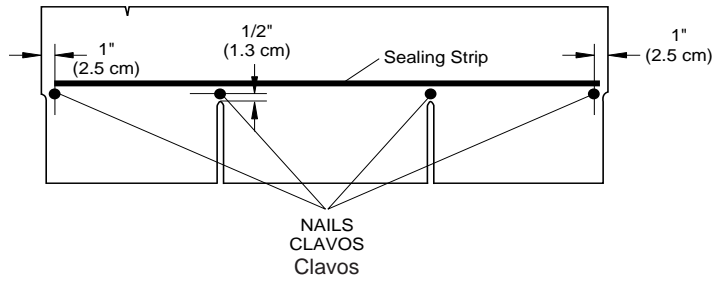

Install first row backwards.  
Instale la primera fila al revés.

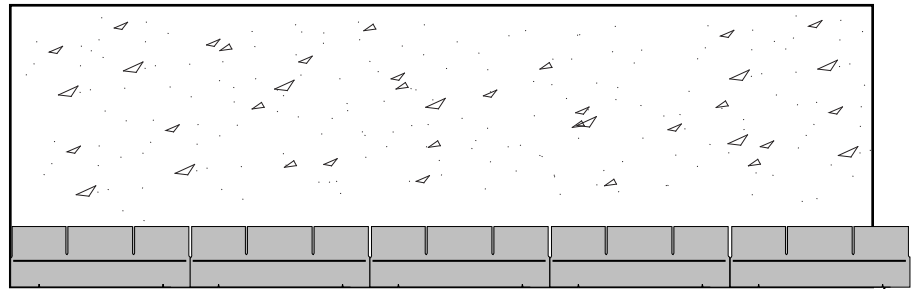

Okay if Shingle Overlaps.

Está bien si la teja sobresale.

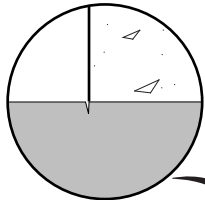

Line up notch on top of Shingle with edge of Roof to stagger the Shingles.  
Alinee el corte encima de la teja con el borde del techo para escalonar las tejas.

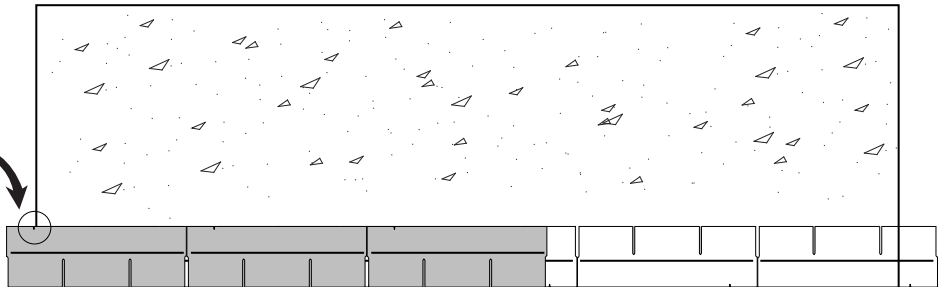

Maintain same deminsion across.  
Mantenga la misma dimensión de un lado al otro.

Flush to edge, stagger each row.  
Nivele al borde, escalone cada fila.

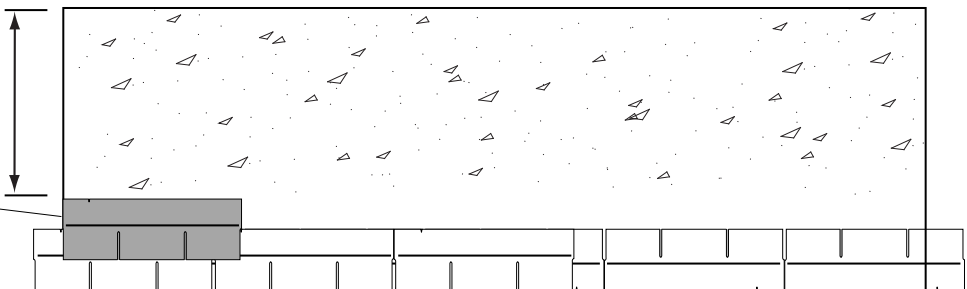

Remove overhanging shingles.  
Quite tejas sobresalientes.

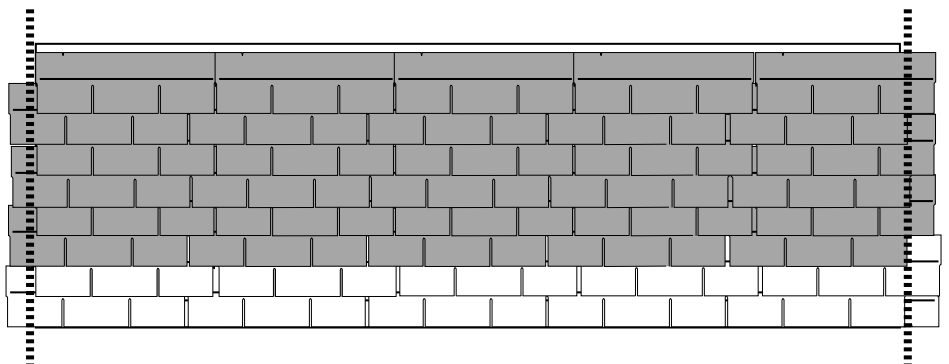

## SHINGLES (Not Included)

### Ridge Cap

Cut Shingles into 3 pieces.  
Corte las tejas en tres partes.

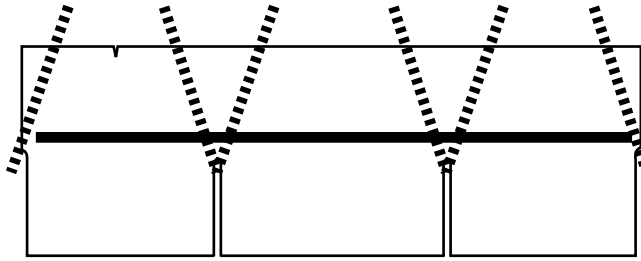

Apply pieces to ridge as shown  
Fije las piezas a la cumbrera  
como en el dibujo

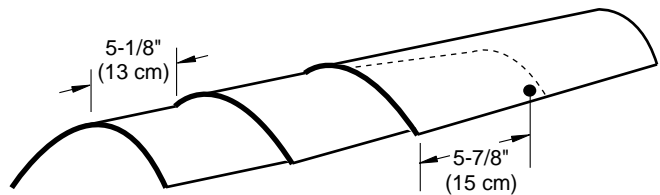

## TEJAS (No Incluidas)

### Tapa de cumbrera

## NAIL INSPECTION INSPECCIÓN DE CLAVOS

Check for protruding nails, pound any protruding nails into the wood or cut them off flush.

Inspeccione para clavos sobresalientes; hínque clavos sobresalientes en la madera o córtelos nivelados con la madera.

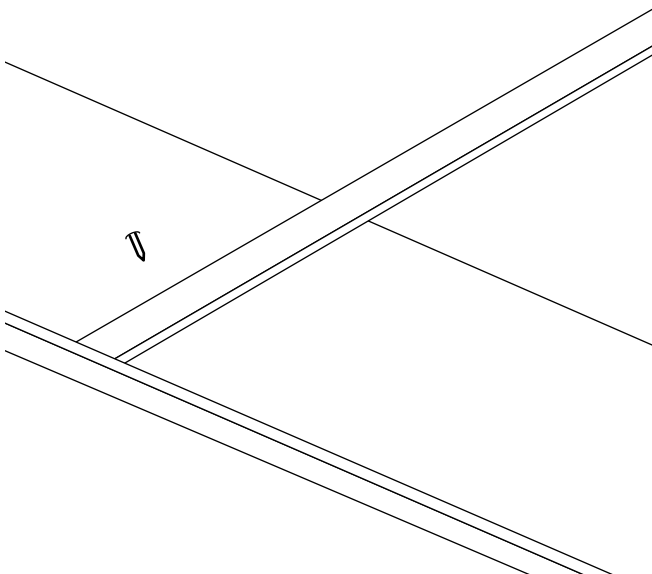

## REQUIRED MAINTENANCE MANTENIMIENTO NECESARIO

Keep grass trimmed and away from building  
Corte y quite la hierba cerca del edificio.

Keep Sprinklers away from building  
No use rociadores cerca del edificio.

Repaint building as needed and in accordance with paint manufacturer requirements  
Pinte el edificio de nuevo cada dos años.

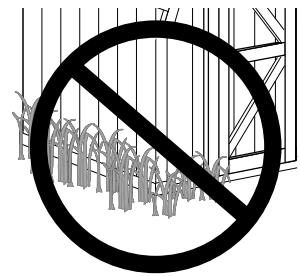

# FLOOR KIT INSTRUCTIONS FOR 10X4 BUILDING EXTENDER

ACTUAL SIZE 120" WIDE X 48" DEEP

#16635

1-800-437-0784

Parts Needed:

- A** 2 - 2x4x24" Bond Boards
- B** 2 - 2x4x96" Bond Boards
- C** 9 - 2x4x45" Floor Joist
- D** 1 - 48"x96"x5/8" Floor Panels
- E** 1 - 23-7/8"x48"x5/8" Floor Panels
- 2" and 3" Nails

This instruction may be different from the one specified in Building instruction.

- Generic floor extender for Marco and Premier Series buildings
- NOT for use with Solar Shed.
- Assemble extended floor 16" on center as shown or 24" on center if desired.

**NOTE:** Part letters are not stamped on floor kits.

**ASSEMBLY OF 120" X 48" FLOOR FRAME**

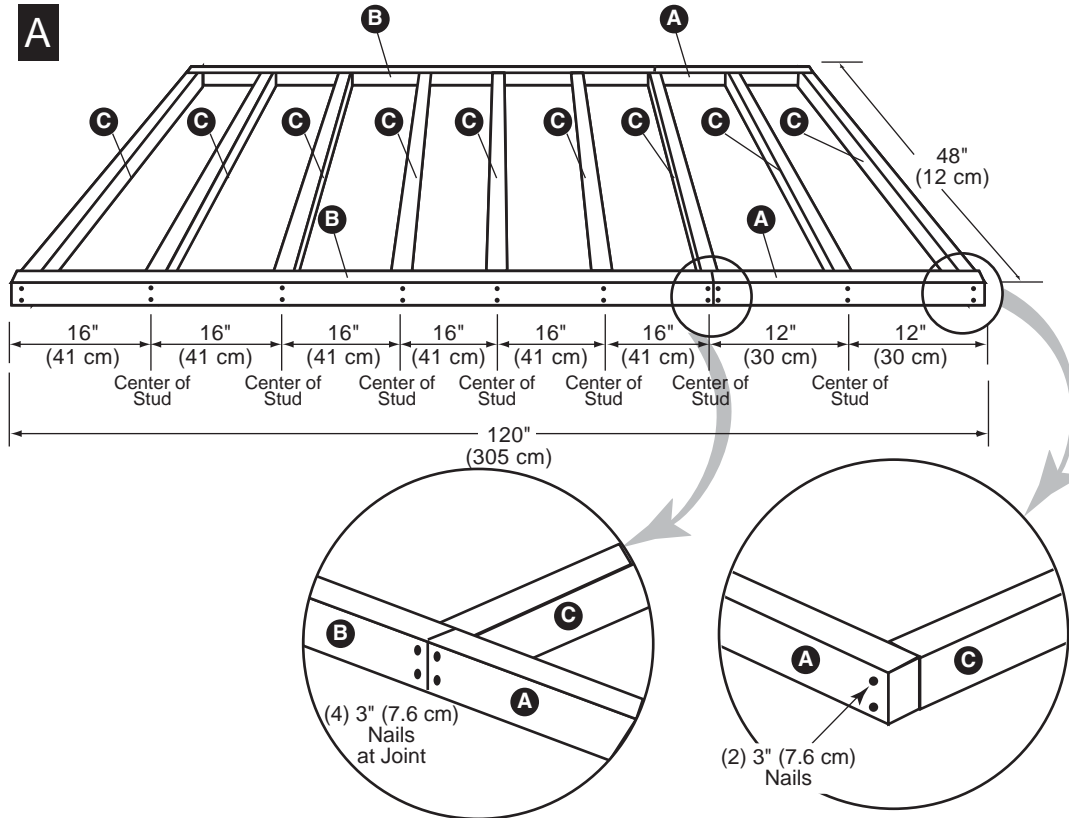

**A:** Position Bond Boards **A** & **B** and Floor Joists **C** as shown.

Using 3" nails, nail twice through each Bond Board **A** & **B** into each end of each Joist **C**, keeping pieces flush at top and ends, and maintain 16" and 12" spacing as shown. Where **A** & **B** join together use 4-3" nails.

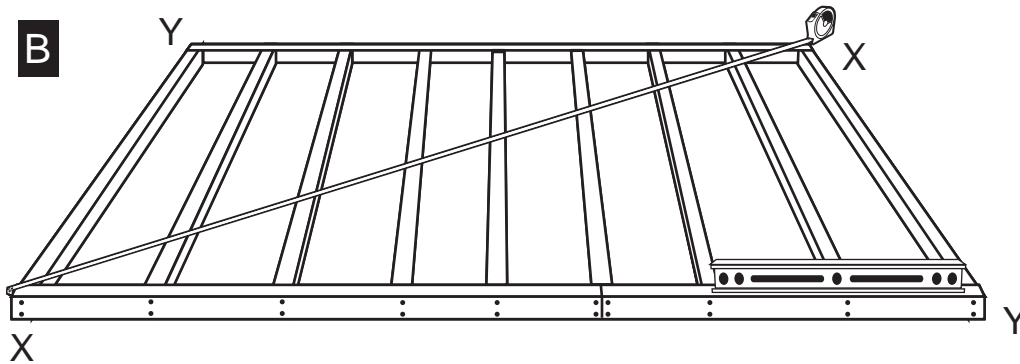

**B:** Completed Floor Frame should be positioned at building site, leveled, using shims between floor frame and ground before proceeding to Floor Panel Attachment.

Square frame by making corner-to-corner measurements (**X** to **X** and **Y** to **Y**) the same.

# 10X4 FLOOR KIT INSTRUCTIONS CONTINUED

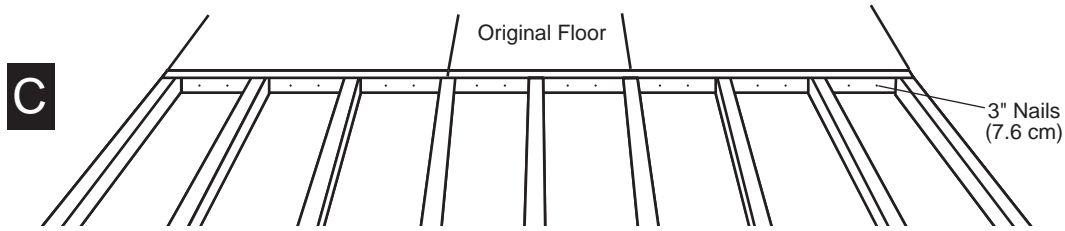

**C:** Attach 10x4 Extender Floor Kit to original 10x8 or 10x10 floor kit with (2) 3" nails between every joist as shown.

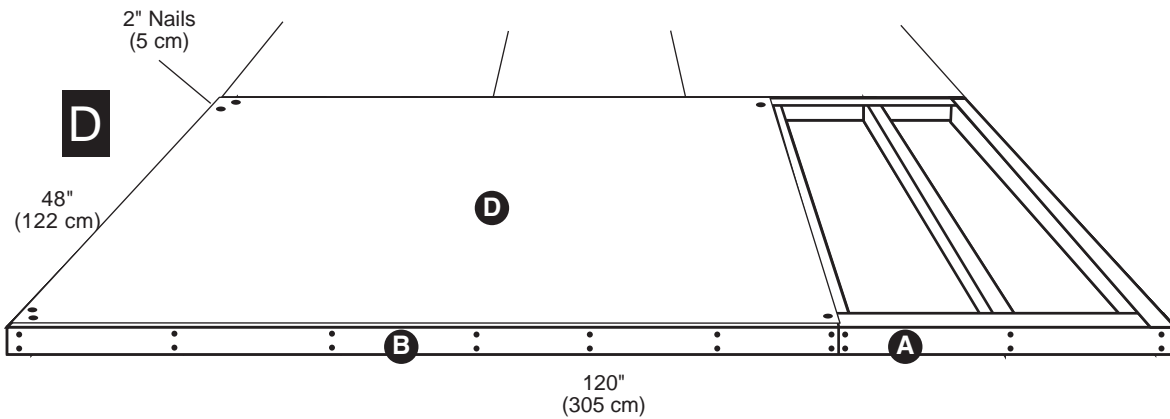

**D:** Position a 48 x 96" Floor Panel **D** flush to the outside edges of sides and back of Floor Frame. Secure panel with two 2" nails at outside corners and one 2" nail at other corners.

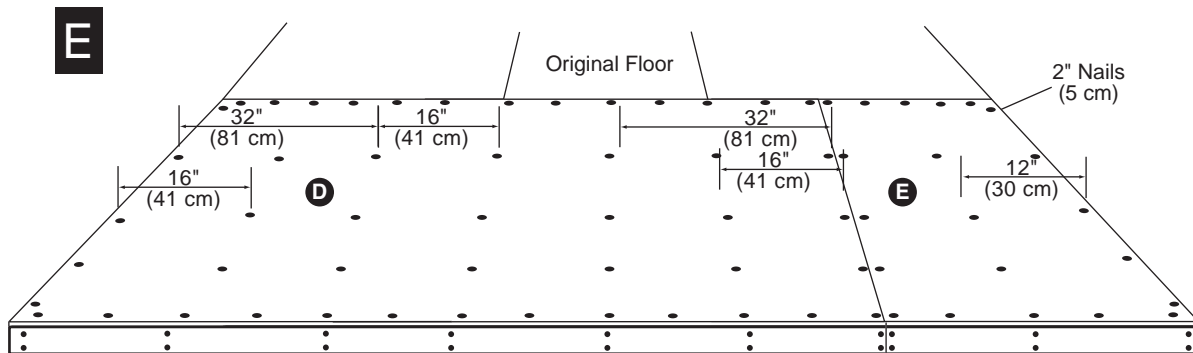

Nails every 12" (30 cm) through Floor Panels into all Floor Bond Boards and Floor Joists

**E:** Position a 23-7/8" x 48" Floor Panel **E** flush against first panel and flush to edges of Floor Frame. Secure panel with two 2" nails at outside corners and one 2" nail at the other corners.

Note: Mark a line on the Floor Panel over the center of each Floor Joist using a pencil and a piece of lumber from the kit (or use a chalk line) to make nailing easier.

With Floor Panels flush to outside edges of Floor Frame, nail with 2" nails every 12" through Floor Panels into all Floor Bond Boards and Floor Joists.

Your Floor is now complete. Check to be sure it is properly positioned and leveled to ground before beginning assembly of your Wooden Storage Building.

# FLOOR KIT INSTRUCTIONS FOR 10x8 and 10x16 BUILDINGS

ACTUAL SIZE • 120" WIDE x 96" DEEP (10X8)  
• 120" WIDE x 192" DEEP (10X16) **#16630**

1-800-437-0784

Parts Needed:

- A** 2 - 2x4x48" Bond Boards
- B** 2 - 2x4x72" Bond Boards
- C** 9 - 2x4x93" Floor Joist
- D** 2 - 48"x96"x5/8" Floor Panels
- E** 1 - 23-7/8"x96"x5/8" Floor Panels  
- 2" and 3" Nails

This instruction may be different from the one specified in Building instruction.

- Use for Premier Series Buildings only, cannot be used for a Marco Series Building or Premier Solar Shed

**NOTE: Part letters are not stamped on floor kits.**

## ASSEMBLY OF 120" x 96" FLOOR FRAME

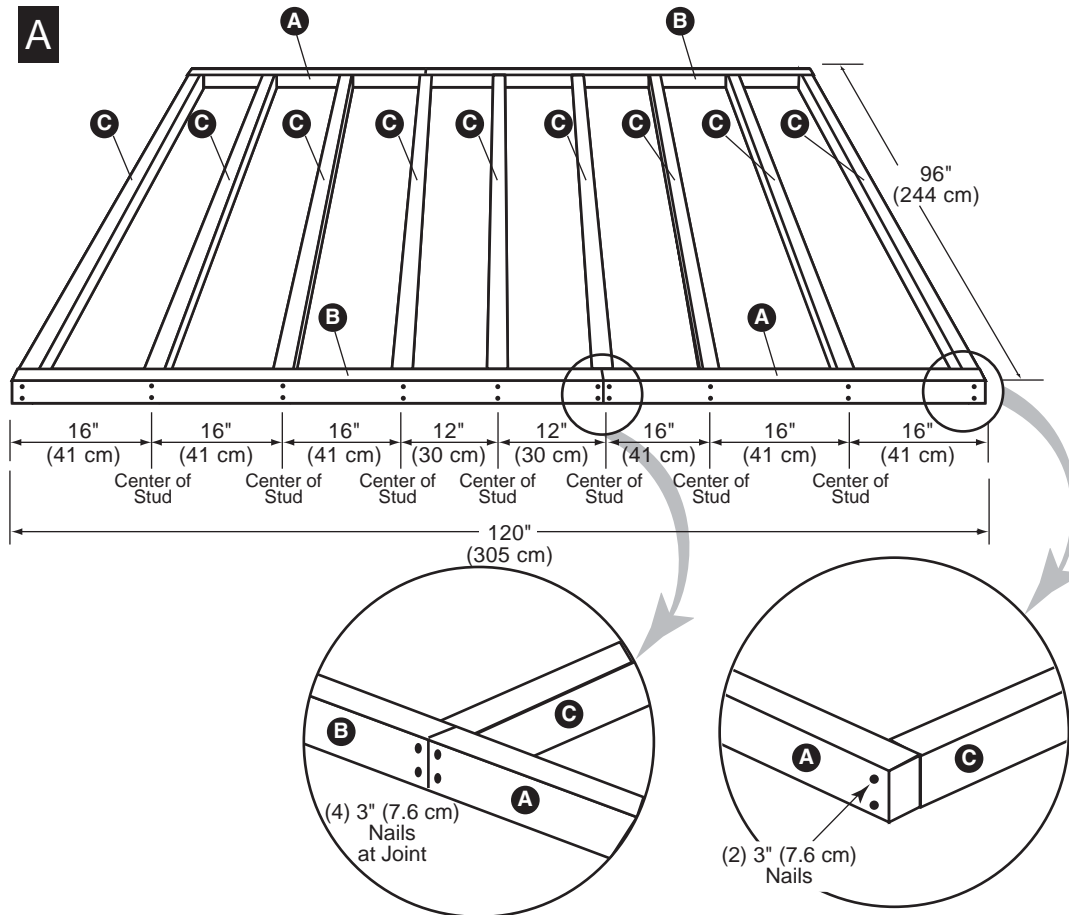

**A:** Position Bond Boards **A** & **B** and Floor Joists **C** as shown.

Using 3" nails, nail twice through each Bond Board **A** & **B** into each end of each Joist **C**, keeping pieces flush at top and ends, and maintain 16" and 12" spacing in middle as shown. Where **A** & **B** join together use 4-3" nails.

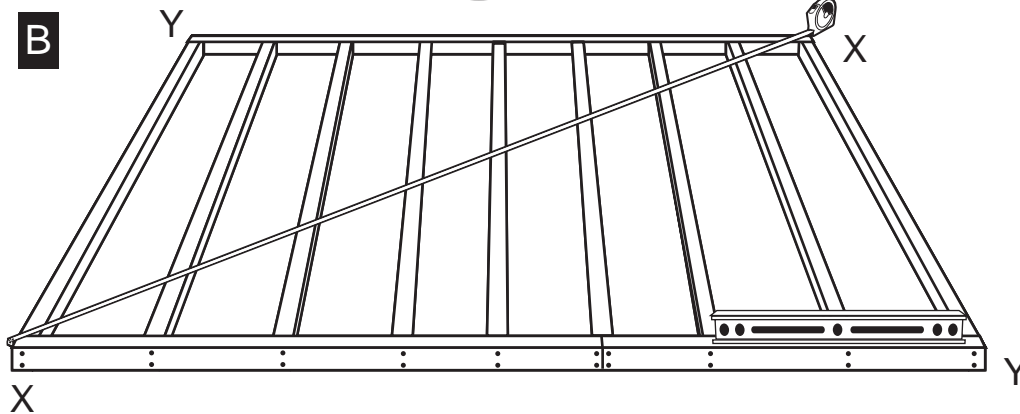

**B:** Completed Floor Frame should be positioned at building site, leveled, using shims between floor frame and ground before proceeding to Floor Panel Attachment.

Square frame by making corner-to-corner measurements (**X** to **X** and **Y** to **Y**) the same.

# 10x8 and 10x16 FLOOR KIT INSTRUCTIONS (CONTINUED)

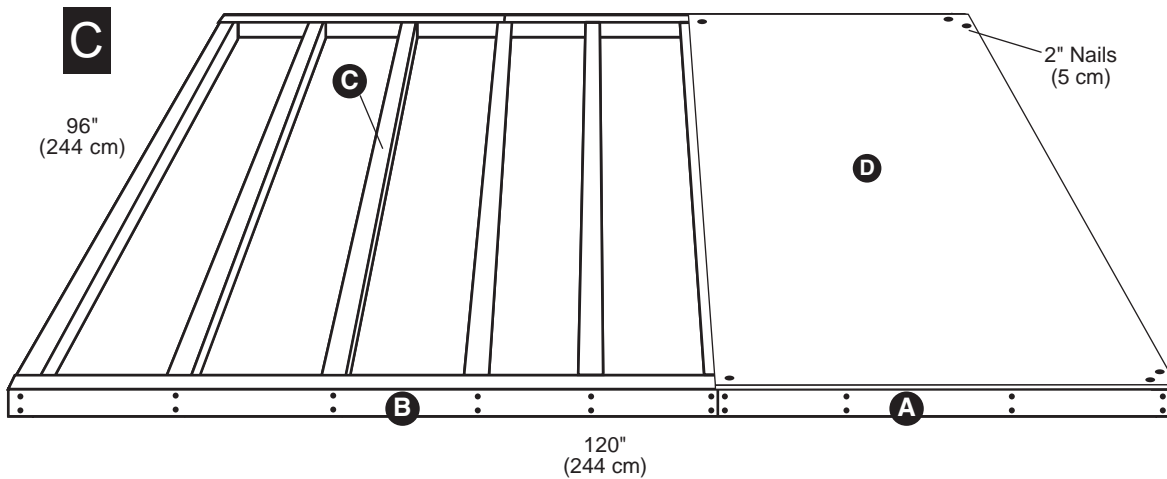

**C:** Position a 48 x 96" Floor Panel **D** flush to the outside edges of sides and back of Floor Frame. Secure panel with two 2" nails at outside corners and one 2" nail at other corners.

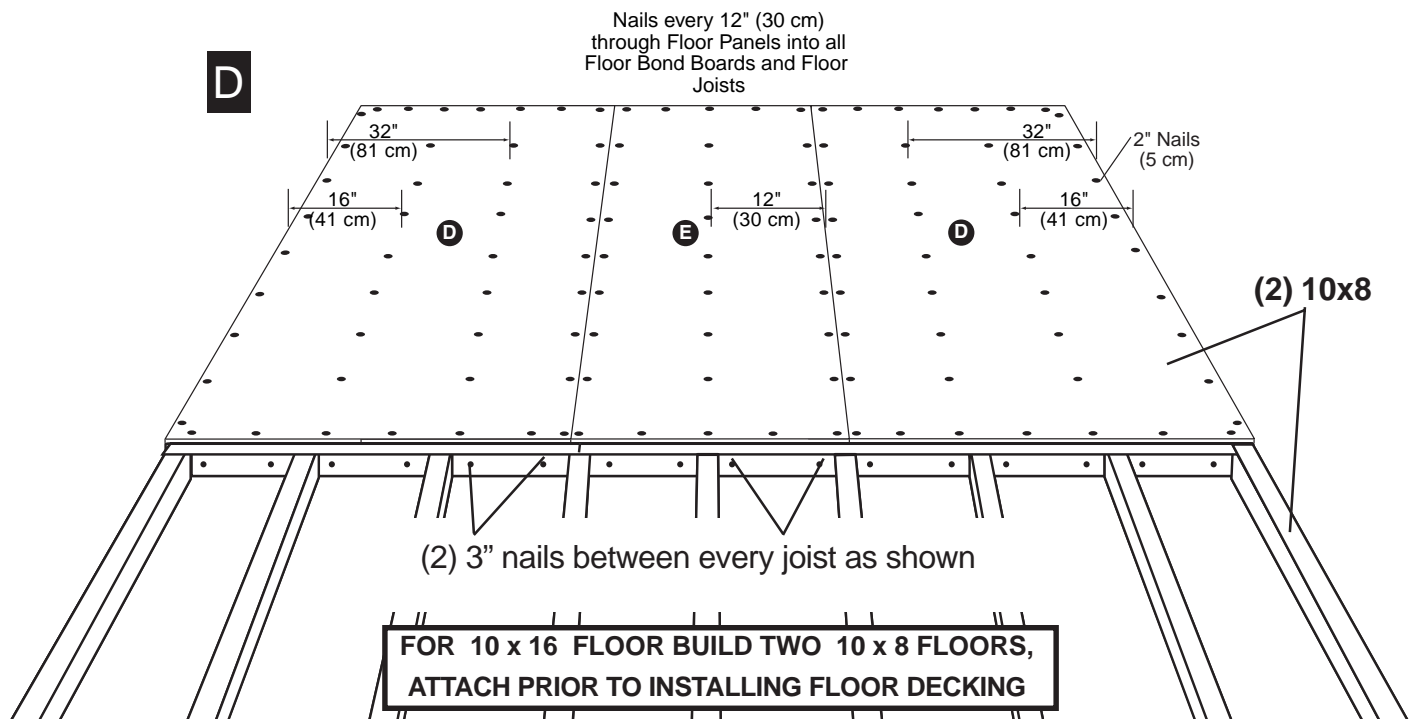

**D:** Position a 23-7/8" x 96" Floor Panel **E** flush against first panel and flush to edges of Floor Frame. Secure panel with one 2" nail at outside corners.

Position the other 48" x 96" Floor Panel **D** flush against second panel and flush to edges of Floor Frame. Secure panel with two 2" nails at outside corners and one 2" nail at each of other corners.

**Note:** Mark a line on the Floor Panel over the center of each Floor Joist using a pencil and a piece of lumber from the kit (or use a chalk line) to make nailing easier.

With Floor Panels flush to outside edges of Floor Frame, nail with 2" nails every 12" through Floor Panels into all Floor Bond Boards and Floor Joists.

Your Floor is now complete. Check to be sure it is properly positioned and leveled to ground before beginning assembly of your Wooden Storage Building.

**Limited Conditional  
Warranty \***

## WARRANTY

Backyard Storage Solutions, LLC warrants the following:

1. Every product is warranted from defects in workmanship and manufacturing for one year.
2. All hardware and metal components are warranted for two years.
3. Trim is warranted for 10 years.
4. Waferboard siding and sheathing is warranted for two years.
5. SmartSide™ siding is warranted for 10 years on all Marco series buildings and 15 years on all Premier Series buildings.
6. Timber series buildings' siding and trim are warranted for 10 years.
7. Solar Shed windows are warranted for 1 year.
8. Cedar lumber is warranted for 15 years.
9. Cedar doors and Cedar Garden Center are warranted for 10 years.
10. Metal roof is warranted for 25 years.

Backyard Storage Solutions, LLC will repair, replace or pay for the affected part. In no event shall Backyard Storage Solutions, LLC pay the cost of labor or installation or any other costs related thereto. All warranties are from date of purchase. If a cash refund is paid on an affected part, it will be prorated from the date of purchase.

## CONDITIONS

The warranty is effective only when:

1. The unit has been erected in accordance with the assembly instructions.
2. The unit has been properly shingled and painted or stained and reasonably and regularly maintained thereafter.
3. The failure occurs when the unit is owned by the original purchaser.
4. Backyard Storage Solutions, LLC has received the warranty registration card within thirty (30) days of purchase and notification of the failure in writing within the warranty period specified above.
5. Backyard Storage Solutions, LLC has had reasonable opportunity during the sixty (60) days following receipt of notification to inspect and verify the failure prior to commencement of any repair work.

## REQUIREMENTS

### Storage Buildings & Playhouses

To validate your warranty, it is necessary to properly maintain your Backyard Storage Solutions, LLC unit; shingle the roof and paint or solid-colored stain the siding using 100% acrylic latex exterior product with a minimum of two (2) coats within sixty (60) days of assembly; caulk above all doors and all horizontal and vertical trim boards; paint and seal all exposed edges, sides and faces of SmartSide™ and waferboard siding to include all exterior walls and all sides and all edges of doors.

### Gazebos, Pergolas & Timber Buildings

To validate your warranty, it is necessary to properly maintain your Backyard Storage Solutions, LLC unit. This includes treating all of the exposed cedar and pine surfaces on your gazebo or timber building with an exterior grade wood preservative, an exterior oil-based semi-transparent stain, an acrylic latex exterior paint or an acrylic latex solid color exterior stain within 30 days of assembly and as needed thereafter to maintain your warranty.

Keep vegetation trimmed away from building and make sure siding panels and trim do not come in contact with masonry or cement. The minimum ground clearance for siding must be one half inch (½ inch) from concrete slab or two and one half inches (2 ½") from the ground when building is erected or constructed on a treated wood floor kit. Water from sprinklers must be kept off unit. In no event will Backyard Storage Solutions, LLC be responsible for any indirect, incidental, consequential or special damages nor for failure(s) that are caused by events, acts or omissions beyond our control including, but not limited to, misuse or improper assembly, improper maintenance (which eventually leads to rot or decay) and acts of God. Backyard Storage Solutions, LLC will not be held responsible for any labor costs incurred to construct your unit.

This warranty gives you certain specific rights that vary from state to state.

## CLAIM PROCEDURE

To make a claim under this warranty, you can either call 1-888-827-9056 or prepare a letter. Please have ready the information below when you call or include the information when writing:

1. The model and size of the product.
2. A list of the part(s) for which the claim is made.
3. Proof of purchase of the Backyard Storage Solutions, LLC item, as shown on the original invoice.
4. Run code, as listed on the yellow warranty card enclosed in the product package.

Mail the above information to:

Backyard Storage Solutions, LLC  
Attn: Customer Service  
1000 Ternes  
Monroe, MI 48162

**\*WARRANTY TERMS MAY VARY OUTSIDE THE U.S.A.**

**IMPORTANT: This is your warranty certificate.**

**Please complete and mail your warranty card to properly validate your warranty.**



**Garantía Limitada  
Condiciona l \***

Backyard Storage Solutions, LLC le garantiza a Ud. que:

1. Cada producto no tiene defecto de mano de obra ni de manufactura por un período de un año.
2. La ferretería y los componentes de metal están garantizados por dos años.
3. La moldura está garantizada por 10 años.
4. La cobertura y el entablado están garantizados por dos años.
5. La cobertura SmartSide™ está garantizada por 10 años para los edificios Marco Series, y por 15 años para los edificios Premier Series.
6. La cobertura y la moldura de los edificios Timber Series están garantizadas por 10 años.
7. Las ventanas del Solar Shed están garantizadas por un año.
8. La madera de cedro está garantizada por 15 años.
9. Las puertas del cedro y el Centro de jardín del Cedro son justificados durante 10 años.
10. El techo del metal es justificado durante 25 años.

Backyard Storage Solutions, LLC reparará, cambiará o pagará por la pieza afectada. En ningún caso pagará Backyard Storage Solutions, LLC los gastos de instalación o trabajo manual, o cualesquiera otros gastos relacionados a eso.

**Condiciones**

Esta garantía es válida solo cuando:

1. La unidad ha sido construida según las instrucciones.
2. La unidad ha sido cubierta de tejas y pintada de manera correcta y mantenida regularmente.
3. El defecto ocurre mientras la unidad está en la posesión del comprador original.
4. Backyard Storage Solutions, LLC ha recibido la tarjeta de garantía del producto en el plazo de 30 (treinta) días después de comprar la unidad y después de la notificación del defecto por escrito, durante el período de vigencia de la garantía especificada arriba.
5. Backyard Storage Solutions, LLC ha tenido una oportunidad razonable, durante los sesenta (60) días después de haber recibido la notificación, para inspeccionar y averiguar la falla o el defecto antes de comenzar cualquier reparación.

**Requisitos**

**Cobertizos de almacenamiento y Casitas de niños**

Para dar validez a la garantía, es necesario mantener bien su unidad de Backyard Storage Solutions, LLC: cubrir con tejas el techo, pintar la cobertura con un producto 100% de acrílico y de látex para exteriores, usando dos manos de pintura o tinte, como mínimo, en el plazo de sesenta (60) días después de la construcción; masillar arriba de todas las puertas y todos los paneles de moldura horizontales y verticales; pintar y sellar todos los bordes dispuestos al exterior, los lados y las fachadas de la cobertura SmartSide™ y plano, incluyendo todos los muros exteriores y los lados y bordes de las puertas.

**Belvederes, Pergolas y Edificios de Madera**

Para dar validez a la garantía, es necesario mantener bien su unidad. Eso incluye tratar con un preservativo todos los superficies de cedro y de pino dispuestos al exterior, usando un preservativo para madera, un tinte de aceite semitransparente para exteriores, pintura acrílica de látex para exteriores, o un tinte acrílico de látex de un solo color, en el plazo de treinta (30) días después de construir el edificio, y luego como sea necesario.

Mantenga corta toda clase de vegetación cerca del edificio y asegúrese que la cobertura y la moldura no toquen ninguna obra de albañería o el cemento. El margen mínimo entre el suelo y la cobertura debe de ser media pulgada (1/2"), con un base de concreto; dos pulgadas y media (2 1/2") cuando se construye el edificio sobre un base de madera (usando un equipo de madera tratada). No se deben usar rociadores cerca de la unidad. En ningún caso será responsable Backyard Storage Solutions, LLC de daños especiales, incidentales, consiguientes o indirectos, ni de fallas causadas por sucesos, hechos u omisiones fuera de nuestro control; eso incluye, pero no está limitado a: el misuso; la construcción incorrecta; cuidado incorrecto (el cual causa, eventualmente, la putrefacción o la descomposición) y acciones de la naturaleza. Backyard Storage Solutions, LLC no será responsable de ningún gasto de instalación incurrido durante la construcción de la unidad. Esta garantía le da a Ud. ciertos derechos específicos que varían de estado a estado.

Para hacer una reclamación:

Para hacer una reclamación bajo esta garantía, llame al 1-888- 827-9056 o escriba una carta. Favor de tener la siguiente información al llamarnos, o incluirla al escribirnos:

1. El modelo y el tamaño del producto.
2. Una lista de las piezas por las cuales hace Ud. la reclamación.
3. Prueba de compra del producto, como se muestra en la factura original.
4. (Run code) escrita en la tarjeta amarilla de garantía incluida con el producto.

Envíe la información a:

Backyard Storage Solutions, LLC  
Attn: Customer Service  
1000 Ternes  
Monroe, MI 48162  
USA

**\*LAS CONDICIONES DE LA GARANTIA PUEDEN VARIAR FUERA DE ESTADOS UNIDOS**

**IMPORTANTE: Esta página es su certificado de garantía.  
Favor de llenar completamente y enviar la tarjeta de garantía para dar validez a la garantía.**